



CATALOGUE **2026**

BUILT-IN
APPLIANCES

beko



Trust. It's when you make the right choices.
For the right reasons. At home. Just like in life.
Whatever situation you find yourself in,
with Beko you make a lifestyle choice.

It's a feeling.

Whatever life throws at you, **we're by your side.**
With the solutions you need.

To guide you towards **a healthier lifestyle.**

Reducing energy consumption in your home.

Simplifying your life,

with products you can rely on, eliminating all sources
of stress.

The choice is yours.

It's an attitude.

The trust you place in us is an incentive to be
ever more reliable.

The more trust you give us, the more we become
a benchmark brand capable of achieving important
recognition.

We have shaped our vision with passion, dedication,
and serenity.

With great confidence.

Beko, a lifestyle choice.

beko

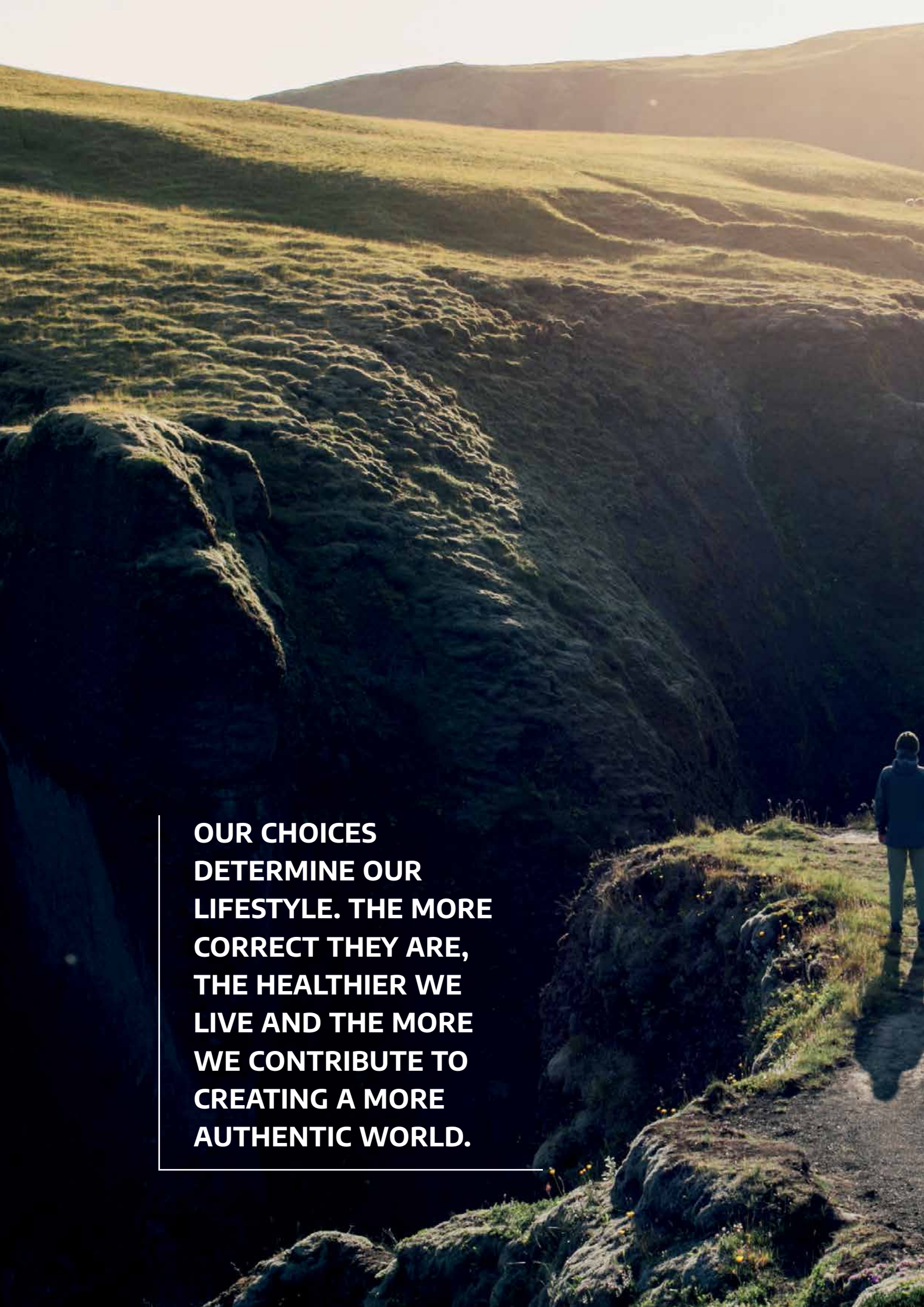
A person in a blue jacket and light-colored pants stands on a rocky, moss-covered cliff edge, looking out over a vast, deep valley. The valley floor is covered in thick, green moss and is illuminated by the warm, golden light of a setting or rising sun. The background shows rolling hills under a clear sky. The overall mood is serene and contemplative.

**OUR CHOICES
DETERMINE OUR
LIFESTYLE. THE MORE
CORRECT THEY ARE,
THE HEALTHIER WE
LIVE AND THE MORE
WE CONTRIBUTE TO
CREATING A MORE
AUTHENTIC WORLD.**

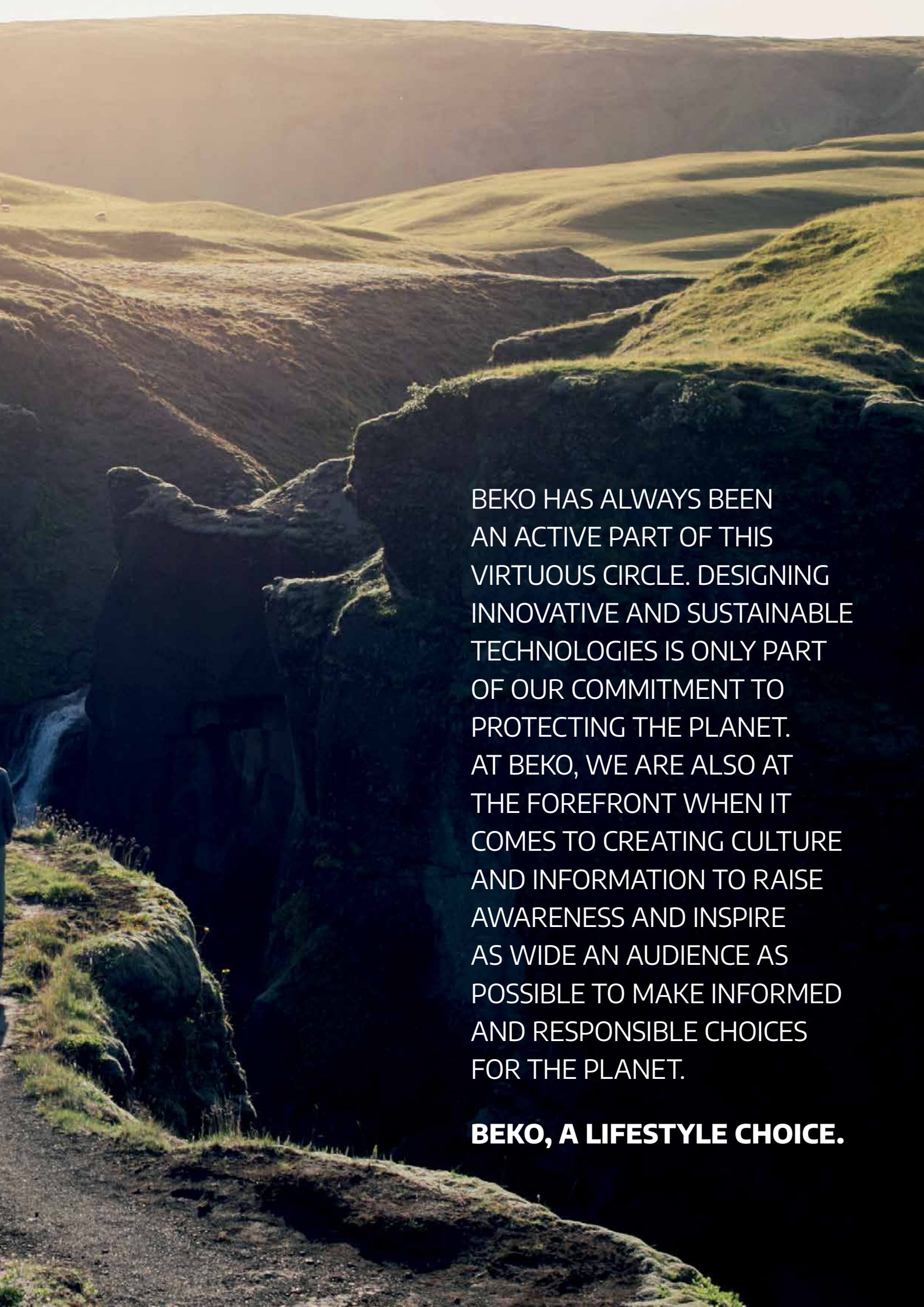

BEKO HAS ALWAYS BEEN AN ACTIVE PART OF THIS VIRTUOUS CIRCLE. DESIGNING INNOVATIVE AND SUSTAINABLE TECHNOLOGIES IS ONLY PART OF OUR COMMITMENT TO PROTECTING THE PLANET. AT BEKO, WE ARE ALSO AT THE FOREFRONT WHEN IT COMES TO CREATING CULTURE AND INFORMATION TO RAISE AWARENESS AND INSPIRE AS WIDE AN AUDIENCE AS POSSIBLE TO MAKE INFORMED AND RESPONSIBLE CHOICES FOR THE PLANET.

BEKO, A LIFESTYLE CHOICE.

Beko, from Europe's Number 1 large home appliances company*



*Source Euromonitor International Limited; Consumer Appliances 2025 edition,
Beko Corp, Large Appliances as per «Major Appliances», GBO, retail volume, 2024 data



a **beko** state of mind



Introducing a Beko state of mind. A feeling you get knowing that your health, finances and emotional well being are well balanced and working for you.

You see at Beko, we promote that holistic confidence throughout our business and across our products.

From innovative technology ensuring your vegetables stay fresher and nutritious for longer, with our unique HarvestFresh.

What's more, our rough and rigorous stress tests maximise reliability, meaning we take the strain – so you can be confident your home doesn't have to.

That's a Beko state of mind.

a **beko** state of mind

01 BUILT-IN REFRIGERATORS 12

Bottom Mount Freezer Double Door 17

Under Counter Single Door 18

02 BUILT-IN LAUNDRY 20

Bottom Mount Freezer Double Door 25

Under Counter Single Door 25

03 BUILT-IN DISHWASHER 26

Fully Integrated Built-In Dishwashers 31

04 BUILT-IN OVENS 34

90 cm Ovens 41

60 cm Ovens 43

Microwave 46

05 BUILT-IN HOBS 48

90 cm Hobs 57

60 cm Hobs 58

30 cm Hobs 61

06 BUILT-IN HOODS 64

INCLINED HOODS 73

WALL MOUNTED HOODS 74

WALL MOUNTED PYRAMID 76

STANDARD HOODS 77

INDEX

BUILT-IN APPLIANCES



- BUILT-IN REFRIGERATORS
- BUILT-IN DISHWASHERS
- BUILT-IN LAUNDRY
- BUILT-IN OVENS
- BUILT-IN HOBS
- BUILT-IN HOODS



a **beko** state of mind

Beko **built-in products** take inspiration from nature, combining harmonious design with reliable performance to support healthier living for you and the planet. The range includes **built-in refrigerators, dishwashers, washing machines, ovens, hobs, microwaves, and hoods**, all designed to integrate seamlessly into modern cabinetry. With a balanced approach to aesthetics, efficiency, and durability, Beko built-in solutions help create a more **sustainable and comfortable home** without compromising on style or everyday practicality.

BUILT-IN REFRIGERATORS

Beko built-in refrigerators are designed to integrate seamlessly into modern kitchen cabinetry, creating a refined and cohesive look that enhances the overall kitchen environment. Inspired by nature, their harmonious design balances clean lines, subtle detailing, and a timeless aesthetic that complements a wide range of interior styles. By fitting discreetly within cabinetry, these refrigerators help maintain visual continuity while offering a thoughtfully organized interior that supports everyday convenience.



Built with a focus on reliable performance and responsible design, Beko built-in refrigerators contribute to healthier living for both you and the planet. Durable materials, efficient operation, and long-lasting construction reflect Beko's commitment to sustainability and quality. Developed by one of Europe's leading home appliance brands, these built-in solutions combine elegance, practicality, and environmental awareness to meet the demands of contemporary kitchens.



01

- **Bottom Mount Freezer Double Door**
- **Under Counter Single Door**

INNOVATIVE TECHNOLOGIES

NEO frost™ Dual Cooling

FASTER COOLING FOR LONGER FRESHNESS

It's important to keep the food fresh for longer in the refrigerator. Also, it is difficult to keep fish in the freezer together with a lovely cake in the fridge without their odours mixing. Beko's separate cooling system technology for each compartment provides faster cooling by maintaining ideal air flow and optimal temperatures with an optimal level of humidity in both the freezer and the fridge. The result is the food stays fresh for longer with no frost build-up or odour transfer.





- ✓ High Efficiency
- ✓ High Durability
- ✓ Low Noise Levels

ProSmart™ Inverter Compressor

High efficiency, high durability, low noise

Don't pay loads of money for electricity bills just for a refrigerator that does the job. You can open the door as many times as you like, ProSmart™ Inverter Compressor technology will adapt and create fewer temperature variations, provide faster cooling with less energy, and allow your food to stay fresh for much longer. The compressor's design provides more durability while being 4 times quieter.



a **beko** state of mind

BCNA290SM

2 Door Freezer Bottom



No Frost

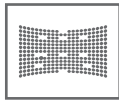

LED Illumination®



ProSmart Inverter Compressor

Specifications

- No Frost
- ProSmart Inverter Compressor
- LED Illumination®
- Total Gross Volume (lt): 300
- Total Net Volume (lt): 270
- Reversible Door
- Hinge Type: Sliding Hinge

Dimensions

- H x W x D: 177.0 x 54.0 x 55.0

Fridge

- Fresh Food Compartment Net Volume (lt): 194

Freezer

- Freezer Compartment Net Volume (lt): 78
- Number of freezer drawer: 3
- Icebox

Performance

- Voltage (v) 220-240
- Frequency (Hz) 50
- Connected Value (w) 130

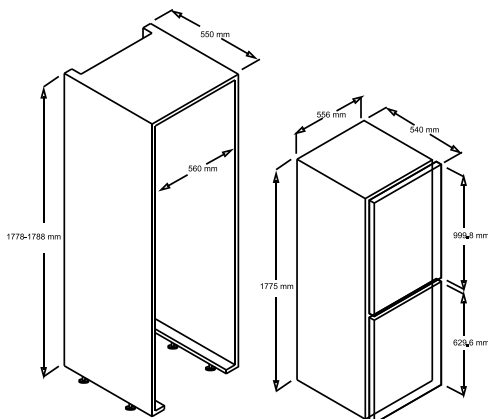

SAP CODE

7525320035

BBCNE400SM

2 Door Freezer Bottom



No Frost



LED Illumination®



ProSmart Inverter Compressor

Specifications

- No Frost
- AeroFlow
- Total Gross Volume (lt): 400
- Total Net Volume (lt): 355
- LED Illumination®
- Reversible Door
- Hinge Type: Sliding Hinge

Dimensions

- H x W x D: 194.0 x 69.0 x 55.5

Fridge

- Fresh Food Compartment Net Volume (lt): 280

Freezer

- Freezer Compartment Net Volume (lt): 75
- Number of freezer drawer: 3
- Icebox

SAP CODE

A90433

BBFNA220SM

Upright Freezer



No Frost

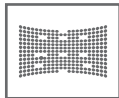

LED Illumination®

Specifications

- No Frost
- LED Illumination®
- Total Net Volume (lt): 220
- Reversible Door
- Hinge Type: Sliding Hinge
- Quick Freeze

Dimensions

- H x W x D: 177.7 x 54.0 x 54.5

Freezer

- Number of freezer drawer: 6

Performance

- Voltage (v) 220-240
- Frequency (Hz) 50
- Connected Value (w) 85

BBLSA310SM

Single Door Larder



No Frost



LED Illumination®



ProSmart Inverter Compressor

Specifications

- LED Illumination®
- Total Net Volume (lt): 309
- Reversible Door
- Hinge Type: Sliding Hinge

Dimensions

- H x W x D: 177.7 x 54.0 x 54.5

Performance

- Voltage (v) 220-240
- Frequency (Hz) 50
- Connected Value (w) 110

SAP CODE

7523420050

SAP CODE

7524120019

BU1153

82cm Built Under Single Door Fridge

**Specifications**

- Static
- Total Gross Volume (lt): 125
- Total Net Volume (lt): 107
- Reversible Door

Performance

- Annual Energy Consumption 25 ° (kwh/year): 175

Dimensions

- H x W x D: 82 x 59.8 x 54.5

Freezer

- Freezer Compartment Net Volume (lt): 15

Fridge

- Fresh Food Compartment Net Volume (lt): 92
- Cabinet Shelf : Glass

Performance

- Voltage (v) 220-240
- Frequency (Hz) 50
- Connected Value (w) 65

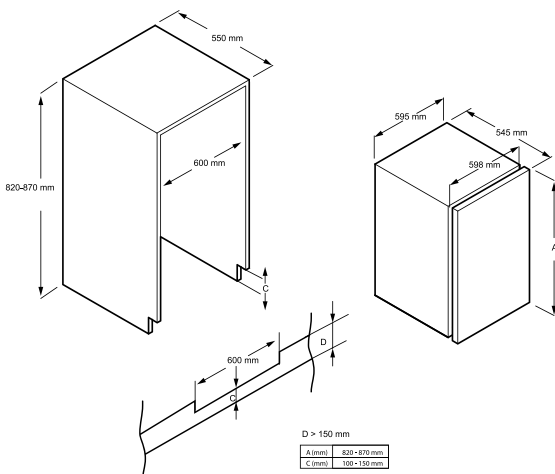

SAP CODE

7248840510

BUILT-IN LAUNDRY

Beko built-in washing machines are designed to integrate seamlessly into modern kitchen or laundry cabinetry, creating a clean and harmonious look that enhances the overall space. Inspired by nature, their refined design combines smooth lines, subtle detailing, and a timeless aesthetic that complements a wide range of interior styles. By fitting discreetly within cabinetry, these washing machines maintain visual continuity while offering an intuitive, well-organized interior that simplifies everyday laundry tasks.



Engineered with performance and sustainability in mind, Beko built-in washing machines support healthier living for both you and the environment. Durable materials, energy-efficient operation, and advanced features reflect Beko's commitment to quality and responsible design. Developed by one of Europe's leading home appliance brands, these built-in solutions perfectly blend practicality, elegance, and environmental awareness to meet the demands of modern households.



02

- Built-In Washing Machine
- Built-In Washer and Dryer



a **beko** state of mind

INNOVATIVE TECHNOLOGIES

Wash&Wear®

1 KG IN 1 HOUR

Was that date really today? You've got no clean clothes, your lucky top is in the dirty basket and you've got to catch the train in an hour. Fortunately for all of you last-minute-date types, the **Wash & Wear®** program in your Beko washer dryer can get a shirt washed and dried in the machine in barely no time at all. Choose from temperature settings of cold- 20°- 30°C and get up to 1kg (5 shirts) washed and completely dried in an hour. You go in the shower, your favourite shirt goes in the wash.





a **beko** state of mind

WBI712W

1 - 7kg Front Load Built-in Washing Machine



DrumClean



AquaWave



Child Lock

Performance

- Maximum Spin Speed 1200
- Voltage (v) 220-240
- Frequency (Hz) 50
- Connected Value (w): 1600-1900

Specifications

- White Color
- Universal Motor
- Digital Display
- AquaWave
- Time Delay: 0-19hours
- Remain Time Display
- Durable Heater

Auxiliary Functions

- Prewash
- Fast+
- Pet Hair Removal
- DrumClean

Programs

- 15 Programs
- Cottons
- Cottons Eco
- Synthetics
- Mini/Mini14'
- Mix
- Wool/HandWash
- Delicates
- Spin+Drain
- Rinse
- Down Wear
- Outdoor/Sports (Goretex)
- DarkWash/Jeans
- Lingerie
- Shirts
- Hygiene

Safety

- Child Lock
- Over Flow Safety

Dimensions

- H x W x D: 82.0 x 60.0 x 55.0

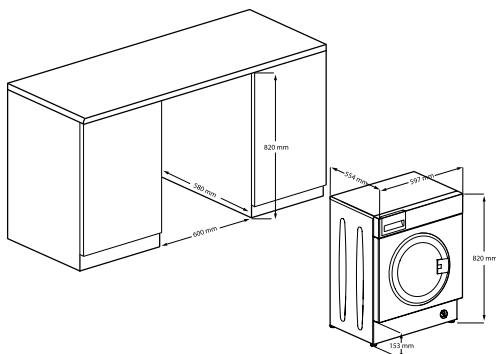

SAP CODE

457100035200

WDBI8514N

8kg Washing/ 5kg Drying Built-in Washer Dryer



DrumClean



AquaWave



Child Lock

Performance

- Maximum Spin Speed: 1400
- Voltage (v) 220-240
- Frequency (Hz) 50
- Connected Value (w): 1600-1900

Specifications

- White
- Digital Display
- Wash&Wear
- ProSmart™ Inverter Motor
- Steamcure
- Aquawave
- BabyProtect+
- Time Delay: 0-24hours
- Remain Time Display

Auxiliary Functions

- Prewash
- Fast+
- Rinse Plus
- Drying
- Drum Clean+

Programs

- 15 Programs
- Cottons
- Cottons Eco
- Synthetics
- Woollens
- Hand Wash
- Shirts
- Rinse
- Spin + Drain
- Express 14
- Daily Xpress
- Cotton Dry
- Synthetic Dry
- BabyProtect+ Wash&Dry
- 5Kg Wash& Dry
- Wash&Wear

Safety

- Child Lock
- Over Flow Safety

Dimensions

- H x W x D: 82.0 x 60.0 x 55.0

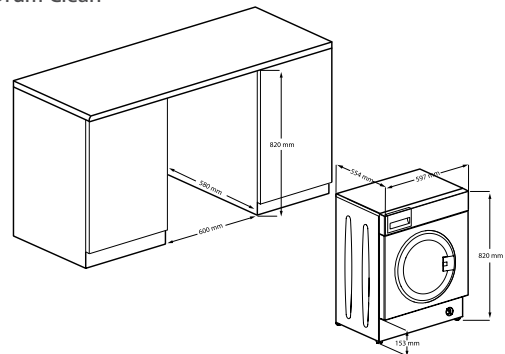

SAP CODE

457000010400

BUILT-IN DISHWASHER

Beko built-in dishwashers are designed to integrate seamlessly into modern kitchen cabinetry, creating a clean, refined, and cohesive appearance that enhances the overall kitchen environment. Inspired by nature, their harmonious design features clean lines, subtle detailing, and a timeless aesthetic that complements a wide range of interior styles. By fitting discreetly within cabinetry, these dishwashers maintain visual continuity while offering a well-organized interior that simplifies everyday dishwashing.



Focused on reliable performance and responsible design, Beko built-in dishwashers support healthier living for both you and the planet. Durable materials, energy-efficient operation, and advanced washing technologies reflect Beko's commitment to sustainability and long-lasting quality. Developed by one of Europe's leading home appliance brands, these built-in solutions combine elegance, practicality, and environmental awareness to meet the demands of contemporary kitchens.



03

- Fully Integrated Built-In Dishwashers

INNOVATIVE TECHNOLOGIES

AqualIntense®

INTENSE CLEANING PERFORMANCE FOR THE DIRTIEST DISHES

Stubborn dirt and hard-to-clean dishes? No problem! **AqualIntense®** creates a powerful cleaning zone with intense water pressure and offers up to 5 times better cleaning performance, so even the toughest pots and pans get a thorough clean. No matter what you put your cookware and dishes through in the kitchen, with **AqualIntense®**, they'll come out spotless every time.

*Tested by internal laboratories on an intensive 70°C program

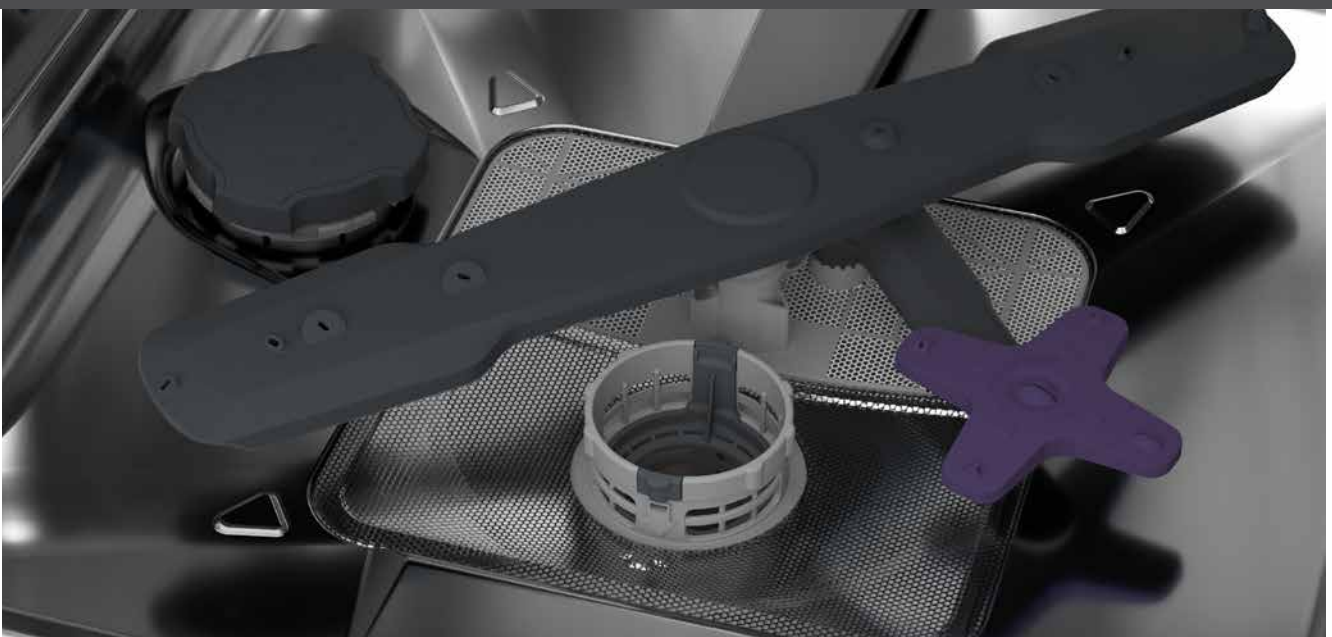



ProSmart™ Inverter Motor

High efficiency, low noise

Want to save on your electricity bills and have a quieter, more efficient dishwasher? The **ProSmart™ Inverter Motor** in your Beko dishwasher reduces friction and is twice as quiet*. With ratings of up to A+++, it'll help you save on water and electricity too.



a **beko** state of mind

DIN48425

60 cm Fully Built in Dishwasher

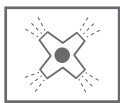

AquaIntense



Fast+ Function



ProSmart Inverter Motor

Performance

- Water Consumption: 9.5 lt
- Number of Place Settings: 14
- Noise Level: 46 dBA
- Voltage (v) 220-240
- Frequency (Hz) 50
- Connected Value (w): 1800-2100

Specifications

- ProSmart™ Inverter Motor
- AquaIntense®
- Fast+ Function
- LedSpot™
- AutoTablet
- Overflow Safety + Aquastop

Dimensions

- H x W x D: 81.8 x 59.8 x 55.0 cm

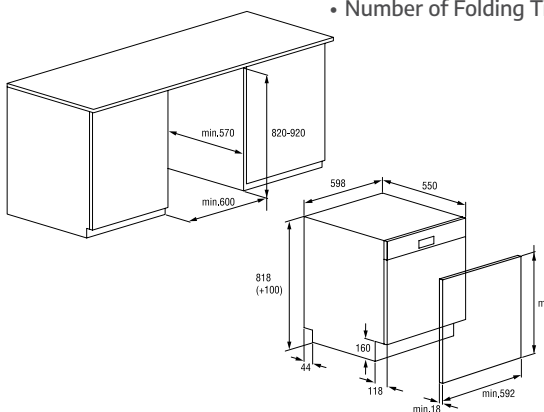

SAP CODE

7672260777

BDIN153E3

60 cm Fully Built in Dishwasher



Fast+ Function



Child Lock

Performance

- Water Consumption: 12.9 lt
- Number of Place Settings: 13
- Noise Level: 48 dBA
- Voltage (v) 220-240
- Frequency (Hz) 50
- Connected Value (w): 1800-2100

Flexibility

- Number of Mug Shelves: 2
- Number of Folding Tines: 4

Safety

- Child Lock

Programs

- Number of Programs: 5
- Eco 50
- Intensive 70
- Clean&Shine
- Quick&Shine
- Mini

Functions

- Half Load
- Fast+ Function
- Hygiene Intense

Dimensions

- H x W x D: 81.8 x 59.8 x 55.0 cm

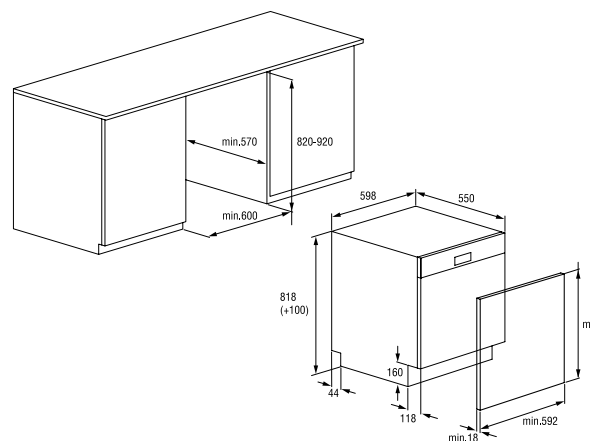

SAP CODE

7622890777

DIS15020

45 cm Slim Built in Dishwasher



Child Lock

Performance

- Water Consumption: 11.9 lt
- Number of Place Settings: 10
- Noise Level: 49 dBA
- Voltage (v) 220-240
- Frequency (Hz) 50
- Connected Value (w): 1800-2100

Safety

- Child Lock

Dimensions

- H x W x D: 81.8 x 44.8 x 55.0 cm

Programs

- Number of Programs: 5
- Intensive 70
- Eco 50
- Clean&Shine
- Quick&Shine
- Mini

Functions

- Extra Drying
- Half Load

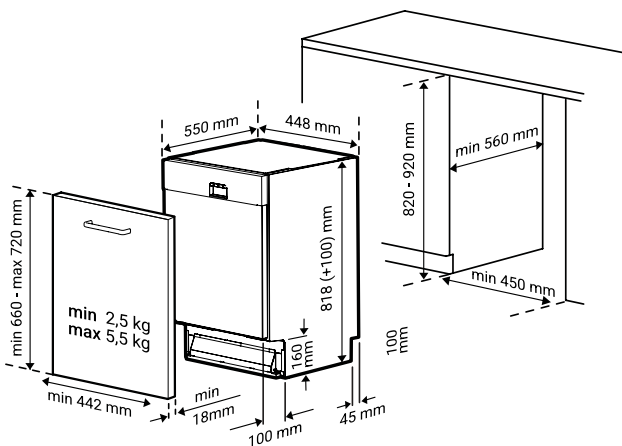

SAP CODE

7682753835



BUILT-IN OVENS

Beko built-in ovens are designed to integrate seamlessly into modern kitchen cabinetry, creating a sleek and cohesive look that enhances the overall kitchen environment. Inspired by nature, their harmonious design combines clean lines, subtle detailing, and a timeless aesthetic that complements a wide range of interior styles. By fitting discreetly within cabinetry, these ovens maintain visual continuity while offering an intuitive, well-organized cooking space that supports everyday culinary needs.



Engineered for reliable performance and responsible design, Beko built-in ovens contribute to healthier living for both you and the planet. Durable materials, energy-efficient operation, and advanced cooking technologies reflect Beko's commitment to sustainability and quality. Developed by one of Europe's leading home appliance brands, these built-in solutions seamlessly blend elegance, practicality, and environmental awareness to meet the demands of contemporary kitchens.



04

- 90cm Built-In Electric Ovens
- 90cm Built-In Gas Oven
- 60cm Built-In Electric Ovens
- 60cm Built-In Gas Oven
- 60cm Built-In Microwave

INNOVATIVE TECHNOLOGIES

AEROperfect™

**PERFECT HOT AIR DISTRIBUTION, MEALS
COOKED TO PERFECTION.**

When hot air isn't evenly distributed throughout your oven, you end up with food burnt at the edges or uncooked in the middle. **AeroPerfect™** technology takes its inspiration from aircraft designs, an industry which understands aerodynamics better than any other. Using this expertise, **AeroPerfect™** uses a constant stream of even airflow all around the oven, all the while minimising temperature fluctuation, so your food is cooked to absolute perfection every single time. All you need is to put your food in the oven and enjoy the perfect results!





LED Screen

LED screen enables you to set cooking time easily. With the start & delay function you can set the time you want your meal to be ready at.



a **beko** state of mind

INNOVATIVE TECHNOLOGIES

Steam Assisted Oven

BETTER BAKING & ROASTING WITH EXTERNAL WATER TANK

Beko ovens with the Steam Assisted Cooking feature help you cook delicious pastries, bread, meat & poultry. Cook easily fluffy pastries and bread with a crispy crust and juicy meat & poultry. During the cooking cycle, water is poured in the cavity directly from the water tank to bottom of oven cavity and steam forms. That makes it safe and convenient to put the water in the easy-to-fill water tank any time during cooking instead of pouring it into the bottom of the oven to create steam. It enables it to cook longer with steam, which prevents the meat & poultry from drying out during roasting.





a **beko** state of mind

BBWMT13300BS

90 cm Multifunctional Oven with 8 Cooking Functions



Soft Door Close



Steam Cleaning

Full Glass Door
(Removable)

Interior Light



Cooling Fan

Specifications

- Product Color: Inox
- LED Display
- Turnspit
- Integrated ignition
- Cooling Fan
- Triple glass door
- Interior lighting
- 5-level Side Racks
- SoftClose Door
- Removable Door Glass
- Steam cleaning
- Multifunctional Cooking
- 8 functions
- Electric Grill

Safety

- Child lock

Dimensions

- HxWxD: 59.5 x 89.6 x 56.5

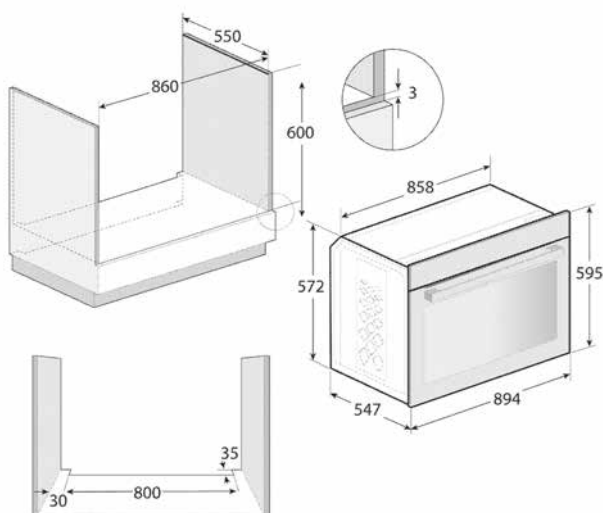

SAP CODE

915111011

BBWMT12301BG

90 cm Multifunctional Oven with 8 Cooking Functions



Soft Door Close



Steam Cleaning

Full Glass Door
(Removable)

Interior Light



Cooling Fan

Specifications

- Product Color: Black
- LED Display
- Turnspit
- Integrated ignition
- Cooling Fan
- Triple glass door
- Interior lighting
- 5-level Side Racks
- SoftClose Door
- Removable Door Glass
- Steam cleaning
- Multifunctional Cooking
- 8 functions
- Electric Grill

Safety

- Child lock

Dimensions

- HxWxD: 59.5 x 89.6 x 56.5

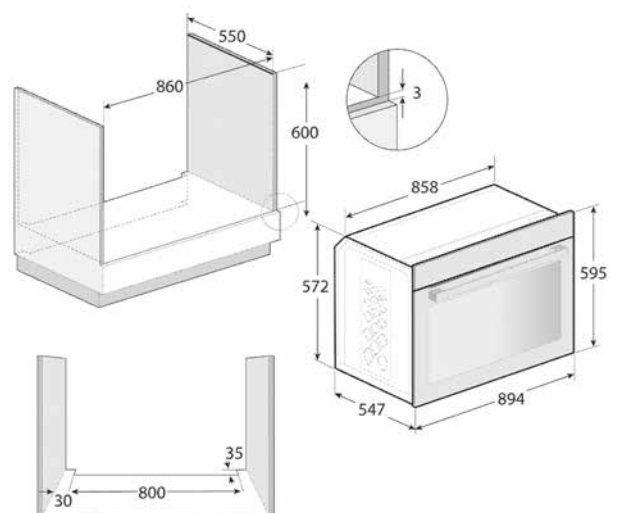

SAP CODE

915111012

BBWHT12106XS

90 cm Gas Oven with Gas Grill Function



Soft Door Close



Full Glass Door (Removable)



Interior Light



Cooling Fan

Specifications

- Product Color: Inox
- Mechanical Timer
- Turnspit
- Integrated ignition
- Cooling Fan
- Triple glass door
- Interior lighting
- 5-level Side Racks
- SoftClose Door
- Removable Door Glass
- Oven Type: Gas Cooking - Fan Assisted
- Gas Grill

Performance

- Voltage (v) 220-240
- Frequency (Hz) 50/60

Dimensions

- H x W x D: 59.5 x 89.6 x 56.5

BBWHT12106XSXB

90 cm Multifunctional Oven with 8 Cooking Functions



Soft Door Close



Steam Cleaning



Full Glass Door (Removable)



Interior Light



Cooling Fan

Specifications

- Product Color: Black
- Mechanical Timer
- Turnspit
- Steam Assisted Cooking
- Steam Cleaning
- Integrated ignition
- Cooling Fan
- Triple glass door
- Interior lighting
- 5-level Side Racks
- SoftClose Door
- Removable Door Glass
- Oven Type: Gas Cooking - Fan Assisted
- Gas Grill

Performance

- Voltage (v) 220-240
- Frequency (Hz) 50/60

Dimensions

- HxWxD: 59.5 x 89.6 x 56.5

SAP CODE

9152131055

SAP CODE

915211003

BCBISA17600KSBS

60 cm Multifunctional Oven with 15 Cooking Functions



Specifications

- LED Display
- Touch Control
- Product Color: Blackout / Pure Black
- AeroPerfect
- Steam Assisted Cooking w. Tank & Steam Generator
- Connectivity: WiFi+BLE
- Bread Making Function
- Airfry Function
- Steam Cleaning
- SoftClose Door
- 3D Cooking
- Triple glass door
- AeroPerfect
- Telescopic Pull-out Shelf System

Dimensions

- H x W x D: 59.5 x 59.4 x 56.7

Performance

- Voltage (v) 220-240
- Frequency (Hz) 50/60

BBIS14300XCSE

60 cm Multifunctional Oven with 9 Cooking Functions



Specifications

- LED Display
- Product Color: Black
- AeroPerfect
- Steam Cleaning
- Steam Assisted Cooking
- SoftClose Door
- Multifunctional Cooking
- 9Cooking Functions
- Triple glass door
- Electric Grill
- 3D Cooking

Performance

- Voltage (v) 220-240
- Frequency (Hz) 50/60

Dimensions

- H x W x D: 59.5 x 59.4 x 56.7

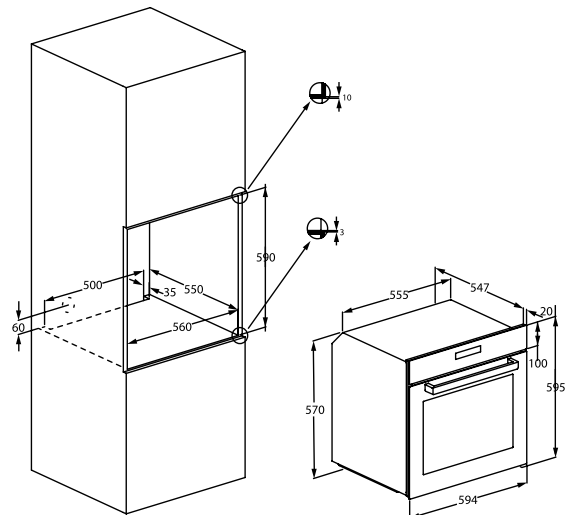

SAP CODE

7754886795

SAP CODE

7768286750

BBIM14300XD

60 cm Multifunctional Oven with 8 Cooking Functions



AeroPerfect



Steam Cleaning

Specifications

- LED Display
- Product Color: Inox
- AeroPerfect
- Steam Cleaning
- Multifunctional Cooking
- 8Cooking Functions
- Triple glass door
- Electric Grill
- 3D Cooking

Dimensions

- H x W x D: 59.5 x 59.4 x 56.7

Performance

- Voltage (v) 220-240
- Frequency (Hz) 50/60

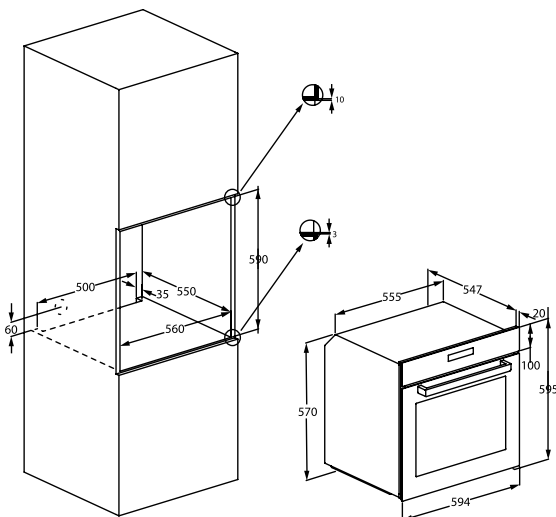

SAP CODE

7727188422

BBIE17300B

60 cm Multifunctional Oven with 6 Cooking Functions



Steam Cleaning

Specifications

- LED Display
- Touch Control
- Product Color: Black
- AeroPerfect
- Steam Cleaning
- 8Cooking Functions
- Triple glass door
- Electric Grill

Dimensions

- H x W x D: 59.5 x 59.4 x 56.7

Performance

- Voltage (v) 220-240
- Frequency (Hz) 50/60

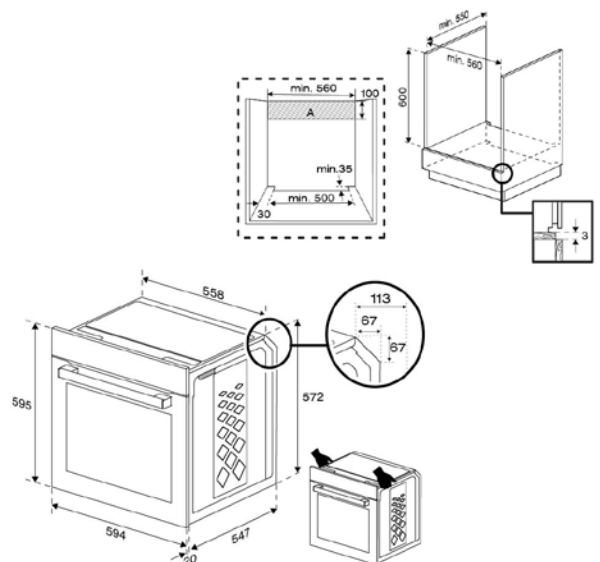

SAP CODE

7757883849

BBIE14100XC

60 cm Multifunctional Oven with 6 Cooking Functions



Steam Cleaning

Specifications

- Mechanical Timer
- Product Color: Inox
- Steam Cleaning
- Fan Assisted Cooking
- 6 Cooking Functions
- Triple glass door
- Electric Grill

Dimensions

- H x W x D: 59.5 x 59.4 x 56.7

Performance

- Voltage (v) 220-240
- Frequency (Hz) 50/60

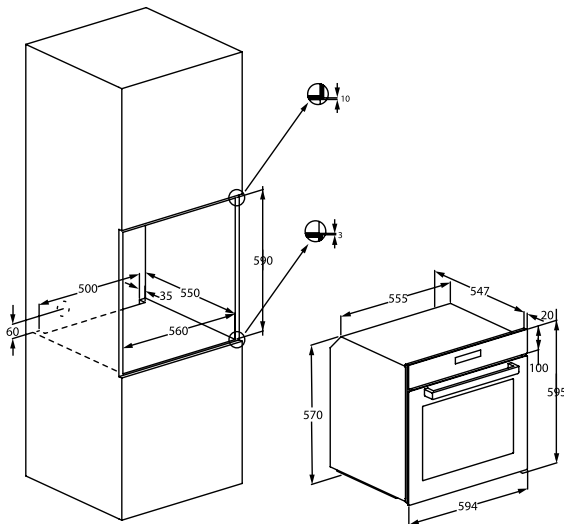

SAP CODE

772188421

BBIHT11100BC

60 cm Gas Oven with Gas Grill Function



Interior Light

Specifications

- LED Display
- Product Color: Black
- Mechanical Timer
- Gas Grill
- Gas Cooking - Fan Assisted
- Turnspit
- Side racks, 5 levels
- Interior lighting
- Triple glass door

Dimensions

- H x W x D: 59.5 x 59.4 x 56.7

Performance

- Voltage (v) 220-240
- Frequency (Hz) 50/60

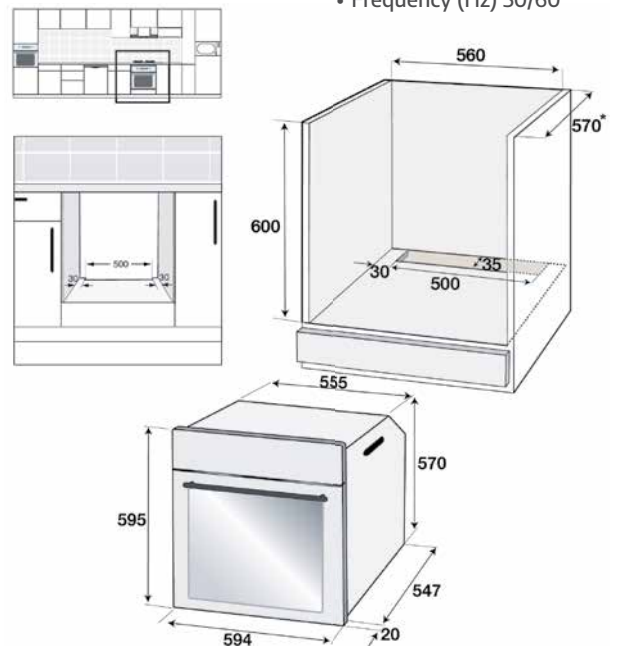

SAP CODE

7779420310

BBIHT12100XC

60 cm Gas Oven with Gas Grill Function



Interior Light

Specifications

- Product Color: Inox
- Mechanical Timer
- Closed door gas grill
- Gas Cooking - Fan Assisted
- Turnspit
- Side racks, 5 levels
- Interior lighting

Dimensions

- H x W x D: 59.5 x 59.4 x 56.7

Performance

- Voltage (v) 220-240
- Frequency (Hz) 50/60

BMGB 25333 X

Microwave with Grill



Interior Light

Specifications

- Microwave Timer: Digital Timer
- Cavity Capacity (lt): 25
- Number of Auto Cooking Functions: 8
- Interior Light
- No. of Microwave Power Levels: 5
- Grill Level: 3
- Door Opening Type: Side Opening - Button

Performance

- Voltage (v) 220-240
- Frequency (Hz) 50/60

Dimensions

- H x W x D: 38.8 x 59.5 x 39.2

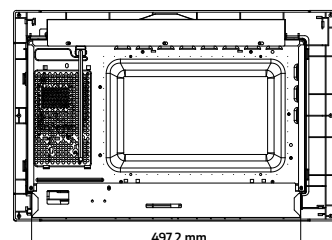
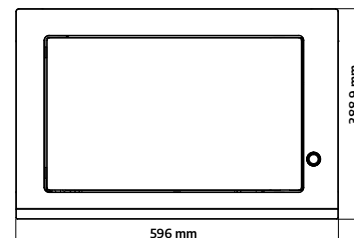

SAP CODE

SAP CODE

9209983200



BUILT-IN HOBS

Beko built-in hobs are designed to integrate seamlessly into modern kitchen worktops, creating a clean, refined, and cohesive appearance that enhances the overall kitchen environment. Inspired by nature, their harmonious design features clean lines, subtle detailing, and a timeless aesthetic that complements a wide range of interior styles. By fitting neatly into the countertop, these hobs maintain visual continuity while offering a thoughtfully arranged cooking surface that supports precise and comfortable meal preparation.



Focused on reliable performance and responsible design, Beko built-in hobs support healthier living for both you and the planet. Durable materials, energy-efficient operation, and advanced cooking technologies reflect Beko's commitment to sustainability and long-lasting quality. Developed by one of Europe's leading home appliance brands, these built-in solutions combine elegance, practicality, and environmental awareness to meet the demands of contemporary kitchens.

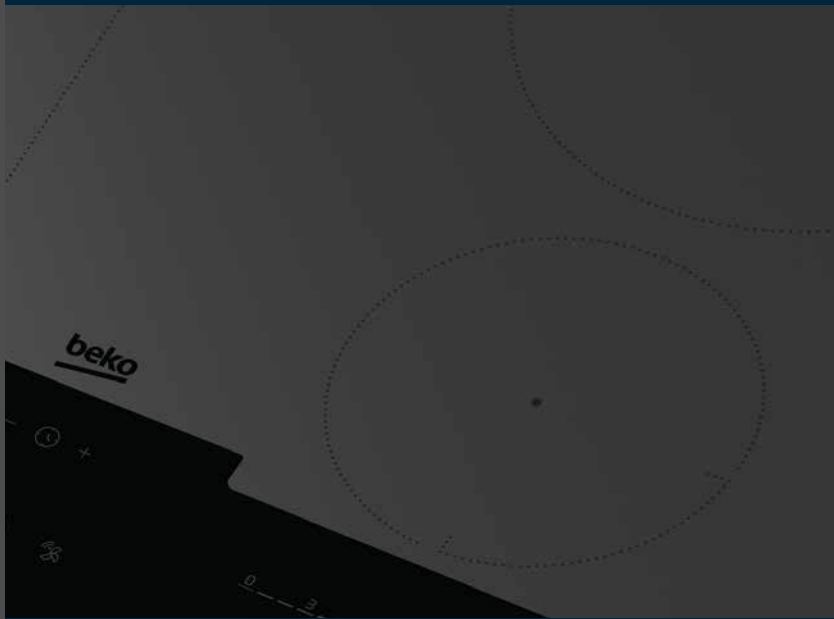

05

- 90cm Gas Hobs
- 60cm Gas Hobs
- 60cm Vitroceramic Electric Hob
- 30cm Vitroceramic Electric Hob(Domino)
- 30cm Glass Gas Hob(Domino)
- 60cm Hotplate Electric Hob
- 30cm Hotplate Electric Hob

INNOVATIVE TECHNOLOGIES

High-Efficiency Gas Burners

FASTER AND MORE EFFICIENT COOKING WITH SPECIAL BURNER DESIGN

Don't let a busy day cost you a healthy meal. Now you can cook every meal faster and more efficiently on the hob. High Efficiency Gas Burners use less gas and cook more quickly than standard burners. So even when you're short on time, you can put your favourite meals on the table fast.



Conventional
Gas Burner

High-Efficiency
Gas Burner

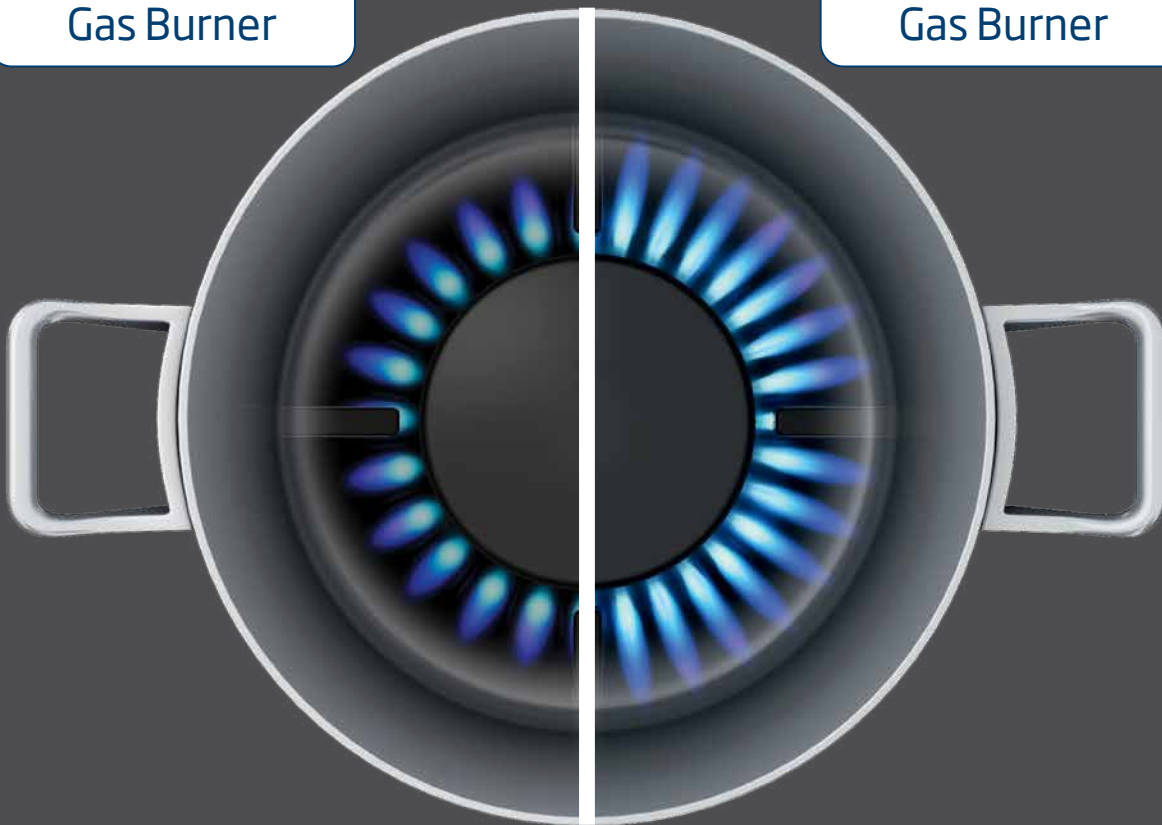

High Power Wok Burner

Maximising cooking power

If you like stir-fry at home, you need a high performing hob. With the Beko High Power Wok Burner you get an extremely intense flame at a hot 5Kw. This allows heat to be more evenly distributed across the bottom of the wok. So, faster noodles with improved cooking performance.



INNOVATIVE TECHNOLOGIES



Gas Hobs and Hotplates

Cast Iron Pan Support



For traditional cooking, a **gas hob works** best. Besides the normal heating and cooking, you can always use the open flame to roast peppers, brown tortillas or stir-fry in a traditional rounded-bottom wok. If your kitchen is not fitted with gas, you can always opt for a **Hotplate**. It only requires electricity to work and is more solid, reliable and cheaper than ceramic hobs.

NO SLIP UPS

Cast iron pan supports enhance the stylish and professional look of your hob, while also providing maximum stability. So, you can use pots and pans of any size without the risk of tilting or sliding.

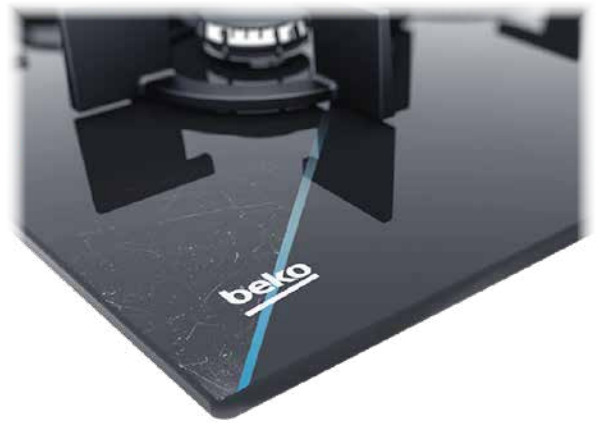
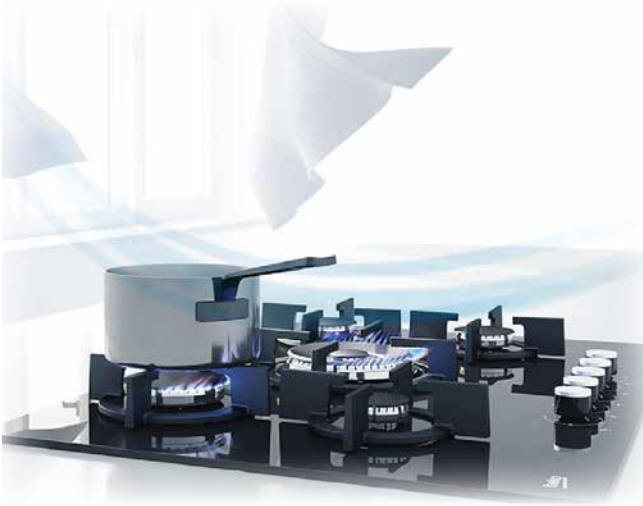

Gas Safety

Tempered Glass Surface



AUTOMATIC GAS CUT-OFF

It's easy for a flame to go out when you're not around, unleashing dangerous gas into the house. The Gas Safety feature will detect when a burner flame is extinguished by an over-boiling pot or a gust of wind, and shut off the gas supply. No leaks, no worries.

SCRATCH-RESISTANT SURFACE & SLEEK DESIGN

Style meets durability in Beko's Glass Surface hobs with their sleek design and easy-to-clean, scratch resistant surface.

INNOVATIVE TECHNOLOGIES



Direct Access Premium



Slim Touch Control

Led-illuminated controls that allow the hob to go totally black when switched off. Has separate controls for each zone with 15 power levels slider, timers, Automatic cooking function, Booster and Hob - Hood Connectivity. Comes with child lock.

Touch control buttons on slim line design allow choosing from 9 power levels. Timer can be set for each zone individually. Comes with child lock function.

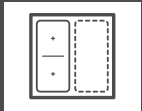
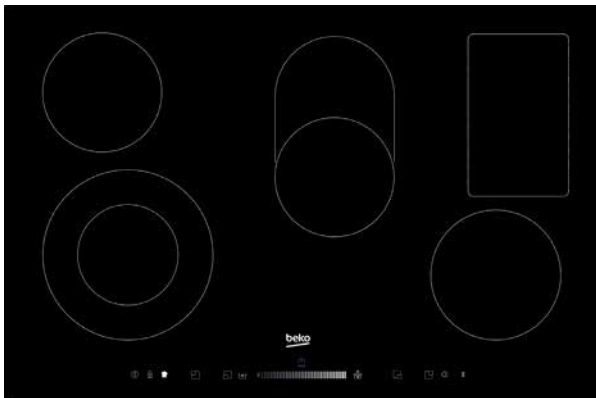

VitroCeramic Hobs

Stylish VitroCeramic Hobs look great in nicely designed kitchens, as their neat glass plate seamlessly integrates with the furniture. They work by heating coiled elements beneath the toughened glass surface and radiating that heat up to the pan.





a **beko** state of mind

HIC 95420 TO

90 cm 5 Vitroceramic Zones

Automatic
shut-off**Main Features**

- Cooking Level: 9
- Front Left Zone: Ø165 - 1200 W
- Front Right Zone: Ø 195 mm -1800 W
- Rear Left Zone: Ø 195 mm -1800 W
- Rear Right Zone: Ø165 - 1200 W
- Center Zone: Ø 300 mm -2700 W
- Residual Heat Indicators
- Display Lock
- Automatic shut-off

Performance

- Voltage (v) 220-240
- Frequency (Hz) 50/60

Dimensions

- H x W x D: 6.3 x 90.0 x 51.0 cm

HISW 95225 SEL

90 cm Gas Hob with 5 Standard Burners



Gas Safety

Integrated
IgnitionCast Iron
Pan Support**Main Features**

- Hob Type : Gas
- 4 Gas and 1 Wok Burners
- Colour : Stainless Steel
- Integrated Ignition
- Central Zone : 4 kW
- Front-left Zone : 1.75 kW
- Rear-left Zone : 1.75 kW
- Front-right Zone : 1 kW
- Rear-right Zone : 3 kW
- Cast-iron Pan Support
- Gas Safety

Performance

- Voltage (v) 220-240
- Frequency (Hz) 50

Dimensions

- H x W x D: 12.0 x 97.0 x 58.5 cm

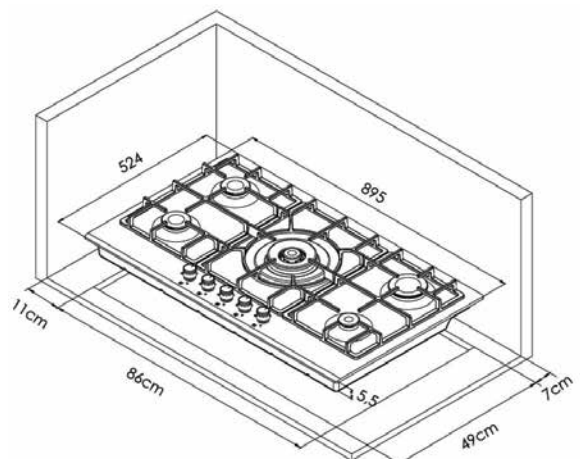

SAP CODE

9217213200

SAP CODE

8809923200

HIMW 95225 SXEL

90 cm Gas Hob with 5 Standard Burners

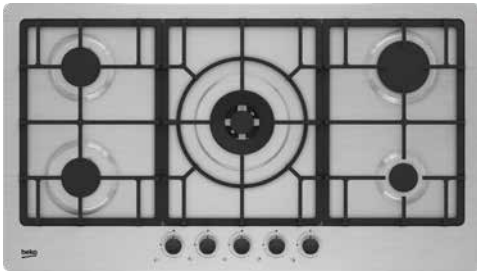

Gas Safety



Integrated Ignition



Cast Iron Pan Support

Main Features

- Hob Type : Gas
- 4 Gas and 1 Wok Burners
- Colour : Stainless Steel
- Integrated Ignition
- Central Zone : 4 kW
- Front-left Zone : 1.75 kW
- Rear-left Zone : 1.75 kW
- Front-right Zone : 1 kW
- Rear-right Zone : 3 kW
- Cast-iron Pan Support
- Gas Safety

Performance

- Voltage (v) 220-240
- Frequency (Hz) 50

Dimensions

- H x W x D: 12.0 x 97.0 x 58.5 cm

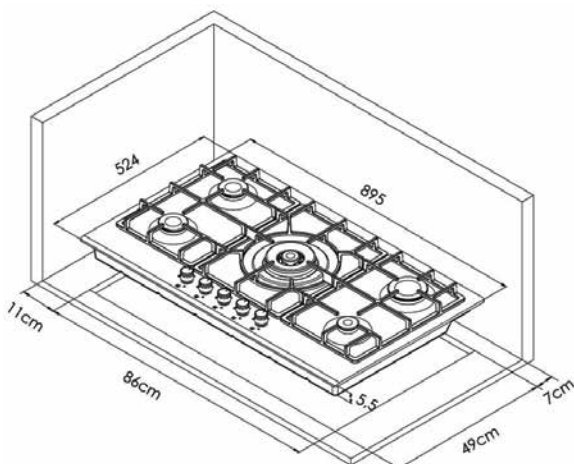

SAP CODE

8809913200

MHII 64700 UFTMT

60 cm Induction Hob



Stop & Go



Power Management



Automatic shut-off

Main Features

- Color: Midnight Black
- 4 Induction with 1 Flexizone
- Cooking level: 9
- Automatic pan recognition
- Automatic shut-off
- On-off Indicator light
- Overflow safety for control unit
- Overheat safety system
- Power Management
- Stop & Go
- Front Left Zone: Ø180 mm - 2200/3100W (Max/Boost)
- Front Right Zone: Ø145mm - 1500/2200W (Max/Boost)
- Rear Left Zone: Ø180 mm - 2200/3100W (Max/Boost)
- Rear Right Zone: Ø210 mm - 2400/3700W (Max/Boost)

Performance

- Voltage (v) 220-240
- Frequency (Hz) 50/60

Dimensions

- H x W x D: 4.8 x 59 x 52 cm

SAP CODE

775187724

HILG 64325 SDX

60 cm Gas Hob with 4 Standard Burners



Gas Safety



High-Efficiency Gas Burner



Cast Iron Pan Support

Main Features

- 60 cm Gas Hob with 3 Gas + 1 Wok
- Front Left Zone: 2,9 kW
- Front Right Zone: 1 kW
- Rear Left Zone: 1,75 kW
- Rear Right Zone: 1,75 kW
- High-Efficient Gas Burners
- Cast Iron Pan Supports
- Gas Safety

Performance

- Voltage (v) 220-240
- Frequency (Hz) 50

Dimensions

- H x W x D: 4.6 x 64.6 x 52.4 cm

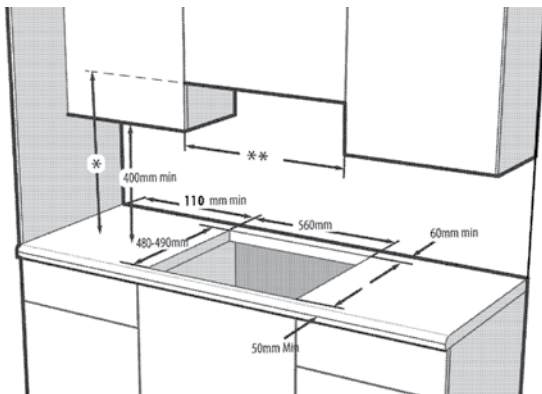

SAP CODE

7702320143

HINW 64229 B65

60 cm Gas Hob with 4 Standard Burners



Gas Safety



High-Efficiency Gas Burner



Cast Iron Pan Support

Main Features

- 60 cm Gas Hob with 3 Gas + 1 Wok
- Front Left Zone: 3,3 kW
- Front Right Zone: 1 kW
- Rear Left Zone: 1,75 kW
- Rear Right Zone: 1,75 kW
- High-Efficient Gas Burners
- Cast Iron Pan Supports
- Gas Safety

Performance

- Voltage (v) 220-240
- Frequency (Hz) 50

Dimensions

- H x W x D: 5.1 x 64.6 x 52.4 cm

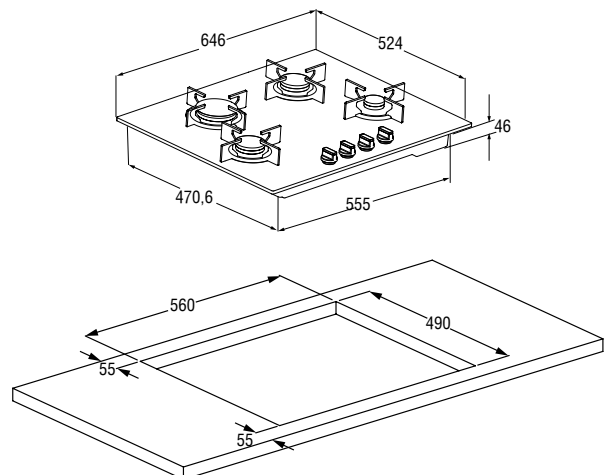

SAP CODE

7712282912

HIAW 64225 SXL

60 cm Gas Hob with 4 Standard Burners



Gas Safety



High-Efficiency Gas Burner



Cast Iron Pan Support

Main Features

- 60 cm Gas Hob with 3 Gas + 1 Wok
- Front Left Zone: 5 kW
- Front Right Zone: 1 kW
- Rear Left Zone: 1,75 kW
- Rear Right Zone: 1,75 kW
- High-Efficient Gas Burners
- Cast Iron Pan Supports
- Gas Safety

Performance

- Voltage (v) 220-240
- Frequency (Hz) 50

Dimensions

- H x W x D: 4.6 x 58 x 51 cm

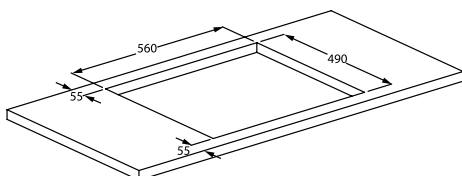
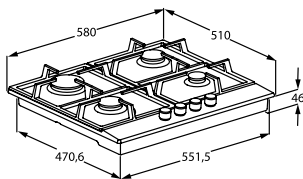
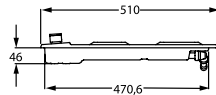

SAP CODE

7712282718

HIC 64400 E

60 cm Vitroceramic Hob

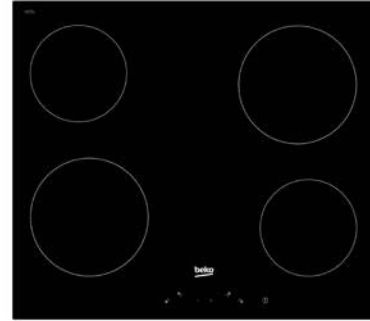

Touch Control

Main Features

- 60 cm Vitroceramic Hob with 4 Vitroceramic
- 9 Cooking Level
- Front Left Zone: Ø180mm - 1800W Hi-light
- Front Right Zone: Ø140mm - 1200W Hi-light
- Rear Left Zone: Ø140mm - 1200W Hi-light
- Rear Right Zone: Ø180 mm - 1800W Hi-light
- Overheat safety system
- Easy Lock Function for Safety
- Direct-Access Control
- LED Display - Touchcontrol (Artouch)
- Glass Surface

Performance

- Voltage (v) 220-240
- Frequency (Hz) 50/60

Dimensions

- H x W x D: 3,7 x 58 x 51 cm

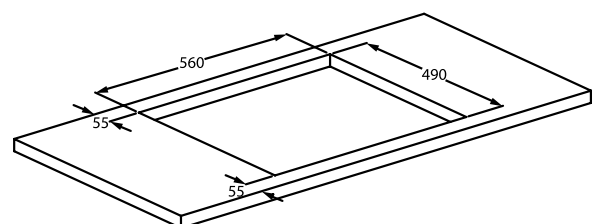
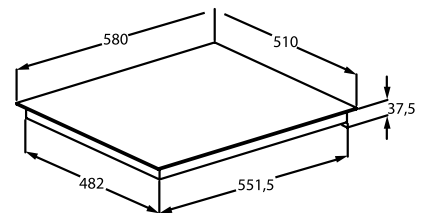

SAP CODE

7756287601

HDMS 32220 FX

30cm Domino Glass Gas Hob



Gas Safety



Cast Iron
Pan Support

Main Features

- 30cm Domino Gas Hob
- 2 Gas Zones
- Front Zone: 1 kW
- Rear Zone: 2.9kW
- Cast Iron Pan Supports
- Gas Safety
- Glass Surface

Performance

- Voltage (v) 220-240
- Frequency (Hz) 50

Dimensions

- H x W x D: 5,2 x 28,8 x 51 cm

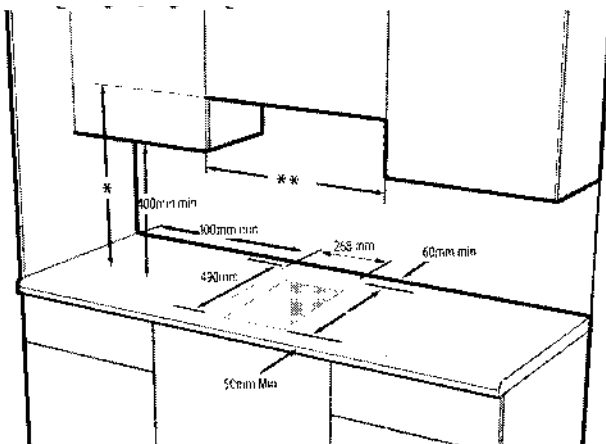

SAP CODE

7725588317

HDCG 32221 FX

30cm Domino Gas Hob



Gas Safety



High-Efficiency
Gas Burner



Cast Iron
Pan Support

Main Features

- 30cm Domino Gas Hob
- 2 Gas Zones
- Front Zone: 1 kW
- Rear Zone: 2.9kW
- Cast Iron Pan Supports
- Gas Safety

Performance

- Voltage (v) 220-240
- Frequency (Hz) 50

Dimensions

- H x W x D: 5,2 x 28,8 x 51 cm

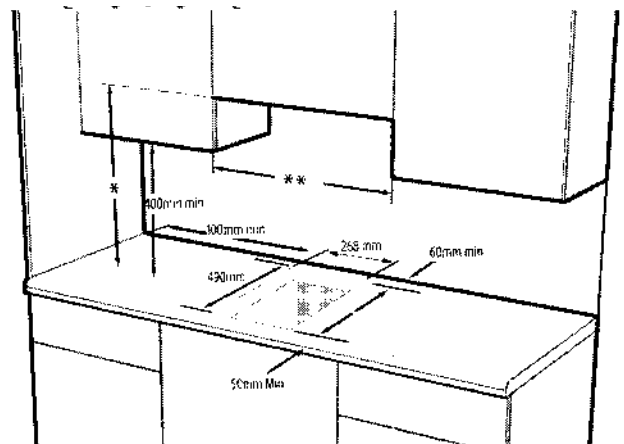

SAP CODE

7725588608

HDMC 32400 TX

30cm Domino Vitroceramic Hob

**Main Features**

- 30cm Domino Vitroceramic Hob
- Glass Surface
- 6 Cooking Level
- 2 Vitroceramic zones
- Front Zone: Ø140mm - 1200W
- Rear Zone: Ø180mm - 1700W
- Overheat safety system
- Total Electric Power (kW): 2.9

Performance

- Voltage (v) 220-240
- Frequency (Hz) 50/60

Dimensions

- H x W x D: 9.5 x 28.8 x 5.1 cm

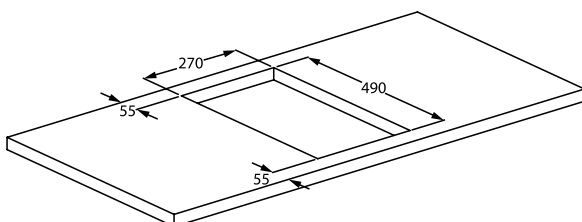
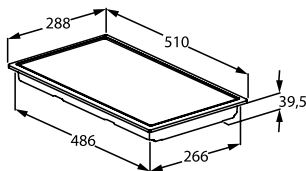

SAP CODE

7724088332

HDCE32200

30 cm Electric Hob

**Main Features**

- 30cm Domino Metal Plate Hob
- 6 Cooking Level
- 2 Hotplate Zones
- Front Zone: Ø145mm - 1500W Rapid
- Rear Zone: Ø180mm - 2000W Rapid
- Total Electric Power (kW): 2.5

Dimensions

- H x W x D: 9.5 x 28.8 x 5.2 cm

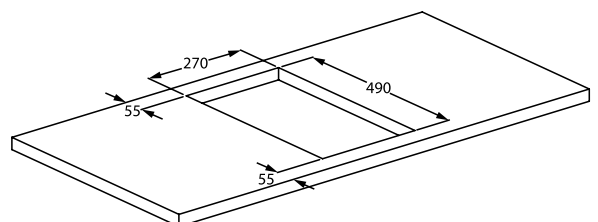
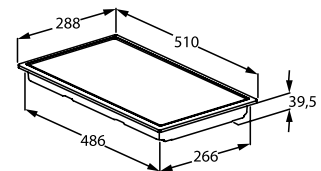

SAP CODE

7724088314



BUILT-IN HOODS

Beko built-in hoods are designed to integrate seamlessly into modern kitchen cabinetry, delivering a clean and cohesive look that enhances the overall kitchen environment. Inspired by nature, their harmonious design combines refined lines, subtle detailing, and a timeless aesthetic that complements a wide range of interior styles. By fitting discreetly within cabinetry, these hoods maintain visual continuity while ensuring an unobtrusive yet effective ventilation solution for everyday cooking.



Engineered for reliable performance and responsible design, Beko built-in hoods support healthier living for both you and the planet. Efficient air extraction, durable materials, and energy-conscious operation reflect Beko's commitment to sustainability and long-lasting quality. Developed by one of Europe's leading home appliance brands, these built-in solutions seamlessly combine elegance, practicality, and environmental awareness to meet the demands of contemporary kitchens.

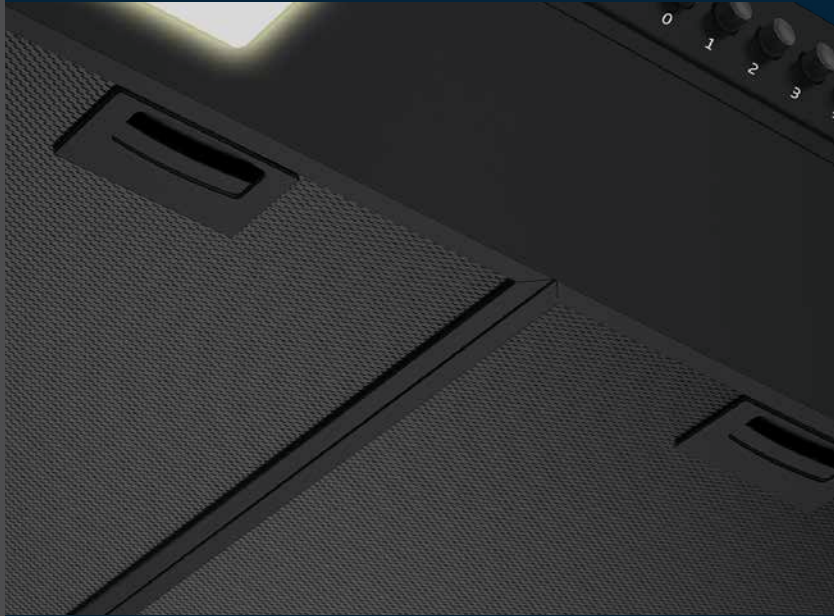

06

- 90cm T-Shape Wall Mounted Chimney Hood
- 60cm T-Shape Wall Mounted Chimney Hood
- 60cm Inclined Chimney Hood
- 90cm Telescopic Chimney Hood
- 60cm Telescopic Chimney Hood
- 90cm Wall Mounted Pyramid Chimney Hood
- 60cm Wall Mounted Pyramid Chimney Hood
- 90cm Recirculation Standard Hood
- 60cm Recirculation Standard Hood

INNOVATIVE TECHNOLOGIES

Intensive Ventilation

MORE VENTILATION POWER

Grilling and frying can create intense odours, so you need ventilation to eliminate these. Beko **Intensive Ventilation** is more efficient than average cooker hoods. It has a booster setting 67%* more powerful than the maximum setting, so you can use it to get rid of strong smells when you're grilling and frying.

*Tested by internal laboratories





Led illumination

Your dish under the spotlight

It's important to see exactly what you're cooking clearly, and kitchen lighting is often gear more towards mood than practicality. With Beko's LED Illumination, your whole hob is bathed in beautiful light, and your cooking made crystal clear. Plus the LED saves energy too.



a **beko** state of mind

INNOVATIVE TECHNOLOGIES

Air Cleaning Mode

HOURLY HANDS-FREE VENTILATION

Like cooking tasty food but not so keen on the strong odours they can leave behind? Beko has just the solution. The Air Cleaning Mode helps to quietly get rid of kitchen odours, without using much energy. Every hour, the hood automatically switches on for 10 minutes at minimum speed, totally refreshing the air in the kitchen.



INNOVATIVE TECHNOLOGIES

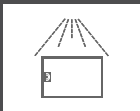
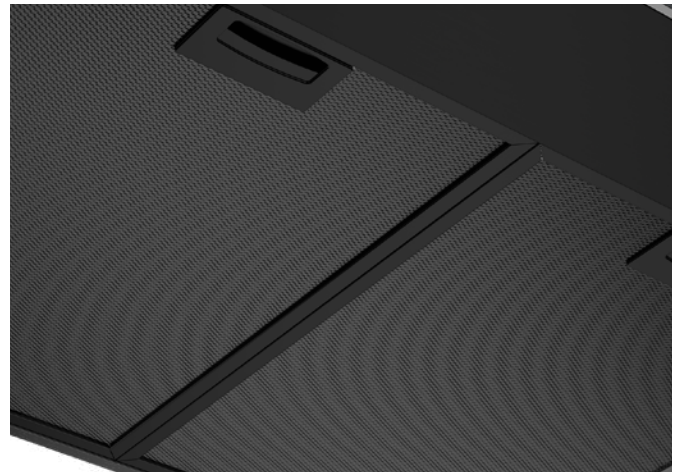
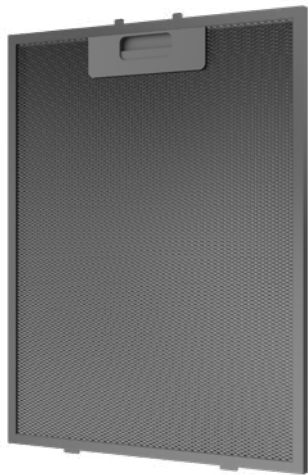

**Dishwasher Safe
Filters**

Carbon Filters

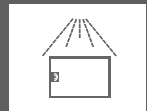

EASY-TO-CLEAN FILTERS

Nobody wants to hand wash greasy hood filters, and now you don't have to with **Dishwasher-Safe Filters**. Just pop them in the dishwasher, run a normal cycle, and then pop them back in the hood. Easy!

SAY GOODBYE TO ODOURS

With houses coming in all shapes and sizes, you might not have a chimney outlet. Beko's built-in hoods have **carbon filters** to keep the air circulating and get rid of any unwelcome cooking odours. So, with or without a chimney, your kitchen will always feel fresh.



Auto Shut Down

15 MINUTES OF AUTOMATIC VENTILATION

After slaving away in a hot kitchen, you want to relax on the sofa, no worry about getting the cooking smells out of your kitchen. Beko **Auto Shutdown technology** lets you switch on your extractor hood for 15 minutes, after which it automatically shuts itself off.

Filter Saturation Light



A GENTLE REMINDER TO CHANGE THE FILTER

Forgetting to change the filters of your hood may cause clogged filters which reduces performance. That's why we've fitted a useful **Filter Saturation Light** and Buzzer to remind you change the filters when required. Your hood measures the interval between your last clean to minimise the amount of effort you have to put in to get rid of any grease residue.



a **beko** state of mind

HCI91631XH

90cm Island Hood

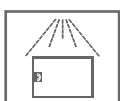

Dishwasher-safe Filters

FUNCTIONS

- Maximum suction level (m3/h): 581
- Air flow rate (m3/h): 288...581-713 m3/hr
- Series: B300
- Intensive suction level (m3/h): 713
- Intensive speed: Yes
- Power Levels: 3 + 1 booster
- Number of Motors: 1
- Average consumption per year: 79.7 kW/h

PERFORMANCE

- Voltage (V) : 220-240
- Frequency (Hz) : 50
- Intensive noise level dB(A) : 73
- Maximum sound level dB(A) : 68
- Noise level dB(A) : 50 - ... - 68-73
- Energy efficiency class : B
- Fluidodynamic efficiency class : B
- Light efficiency class : 76.1
- Total Consumption (W) : 265
- Grease filtration efficiency class : B

FEATURES

- Type of grease filter(s) : Metal - Cassette Filter
- Number of grease filter(s) : 1
- Type of lighting : LED
- Number of lights : 2
- Carbon filter included : Yes
- Automatic shut-off : YES
- Dishwasher safe filters : Yes
- Saturation indicator of the grease filters provided : Yes
- Deflector : Yes
- Check valve : Yes

Dimensions

- H x W x D: 36 x 89.8 x 59.8 cm

SAP CODE

BHCA99642BHE

90cm Inclined Hood



Automatic shut-off

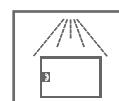

Dishwasher-safe Filters



Touch Control

FUNCTIONS

- Colour: Black
- Hood Type: Inclined
- Touch control
- Number of Light Bulbs: 2
- No. of Power Levels: 3

TECHNOLOGIES

- Dishwasher Safe Filters
- Charcoal Filter
- Air Diverter (Recirculated Operation)
- Auto Shut-Down

PERFORMANCE & CONSUMPTION

- Maximum Ventilation Capacity (m3/h): 613 cu meters/hour
- Minimum Ventilation Capacity (m3/h): 268 cu meters/hour
- Maximum noise level dB(A) : 59
- Minimum noise level dB(A) : 38

Dimensions

- H x W x D: 113.8 x 89.5 x 41.9 cm

SAP CODE

BHCA66741BBHS

60cm Inclined Hood



Automatic shut-off

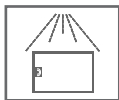

Dishwasher-safe Filters



Touch Control

FUNCTIONS

- Color: Inox
- Hood Type: Inclined
- Intensive Ventilation
- Air-cleaning Mode
- Auto Shut-down
- Touch control
- Number of Light Bulbs: 2
- Light Bulb Power (W): 3

TECHNOLOGIES

- Filter Saturation Indicator
- Dishwasher-safe Filters: 2
- Carbon Filters
- Number of Grease Filters: 1

PERFORMANCE & CONSUMPTION

- Maximum Ventilation Capacity (m³/h): 445 cu meters/hour
- Minimum Ventilation Capacity (m³/h): 220 cu meters/hour
- Intensive Ventilation Capacity (m³/h): 712 cu meters/hour
- Minimum Ventilation Noise Level (dBA): 44 dBA
- Maximum Ventilation Noise Level (dBA): 60 dBA
- Intensive Ventilation Noise Level (dBA): 70 dBA

Dimensions

- H x W x D: 113.8 x 59.5 x 41.9 cm

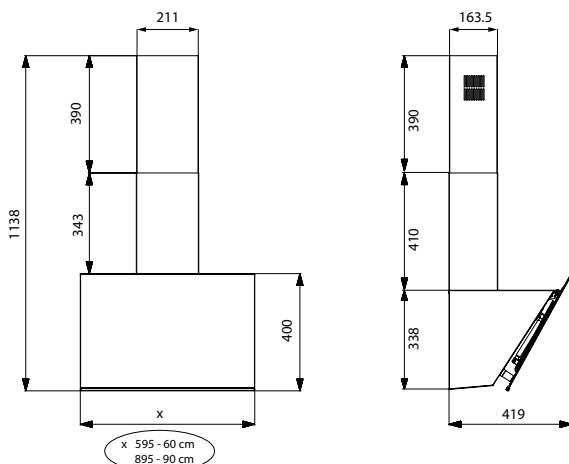
**BHCB96641BBHS**

90cm Wall Mounted Cooker Hood



Automatic shut-off

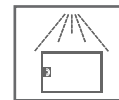

Dishwasher-safe Filters



Touch Control

FUNCTIONS

- Colour: Black
- Hood Type: Wall-mounted
- Intensive Ventilation
- Air-cleaning Mode
- Auto Shut-down
- Touch control
- Number of Light Bulbs: 2
- Light Bulb Power (W): 3

TECHNOLOGIES

- Filter Saturation Indicator
- Dishwasher-safe Filters
- Carbon Filters
- Number of Grease Filters: 3

PERFORMANCE & CONSUMPTION

- Maximum Ventilation Capacity (m³/h): 430 cu meters/hour
- Minimum Ventilation Capacity (m³/h): 200 cu meters/hour
- Intensive Ventilation Capacity (m³/h): 715 cu meters/hour
- Minimum Ventilation Noise Level (dBA): 44 dBA
- Maximum Ventilation Noise Level (dBA): 60 dBA
- Intensive Ventilation Noise Level (dBA): 72 dBA

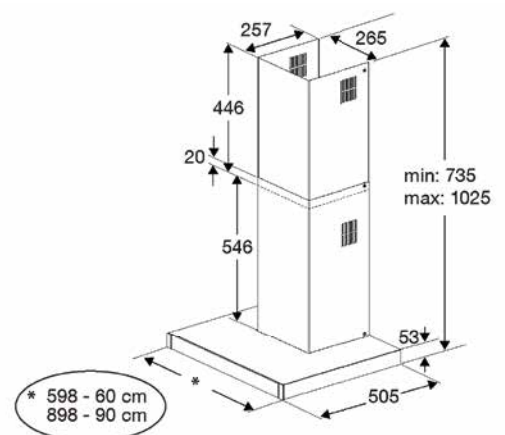
Dimensions

SAP CODE

SAP CODE

BHCB96741BBHS

90cm Wall Mounted Cooker Hood



Automatic shut-off

Dishwasher-safe Filters

Touch Control

FUNCTIONS

- Colour: Inox
- Hood Type: Wall-mounted
- Intensive Ventilation
- Air-cleaning Mode
- Auto Shut-down
- Touch control
- Number of Light Bulbs: 2
- Light Bulb Power (W): 3

TECHNOLOGIES

- Filter Saturation Indicator
- Dishwasher-safe Filters
- Carbon Filters
- Number of Grease Filters: 3

PERFORMANCE & CONSUMPTION

- Maximum Ventilation Capacity (m³/h): 430 cu meters/hour
- Minimum Ventilation Capacity (m³/h): 200 cu meters/hour
- Intensive Ventilation Capacity (m³/h): 715 cu meters/hour
- Minimum Ventilation Noise Level (dBA): 44 dBA
- Maximum Ventilation Noise Level (dBA): 60 dBA
- Intensive Ventilation Noise Level (dBA): 72 dBA

Dimensions

- H x W x D: 102.5 x 89.8 x 50.5 cm

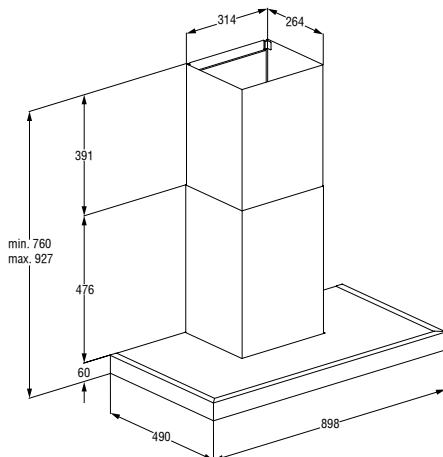

SAP CODE

7706331114

BHCB66641BBHS

60cm Wall Mounted Cooker Hood



Automatic shut-off

Dishwasher-safe Filters

Touch Control

FUNCTIONS

- Color: Inox
- Hood Type: Wall-mounted
- Intensive Ventilation
- Air-cleaning Mode
- Auto Shut-down
- Touch control
- Number of Light Bulbs: 2
- Light Bulb Power (W): 3

TECHNOLOGIES

- Filter Saturation Indicator
- Dishwasher-safe Filters
- Carbon Filters
- Number of Grease Filters: 2

PERFORMANCE & CONSUMPTION

- Maximum Ventilation Capacity (m³/h): 425 cu meters/hour
- Minimum Ventilation Capacity (m³/h): 204 cu meters/hour
- Intensive Ventilation Capacity (m³/h): 710 cu meters/hour
- Minimum Ventilation Noise Level (dBA): 43 dBA
- Maximum Ventilation Noise Level (dBA): 60 dBA
- Intensive Ventilation Noise Level (dBA): 71 dBA

Dimensions

- H x W x D: 102.5 x 59.8 x 50.5 cm

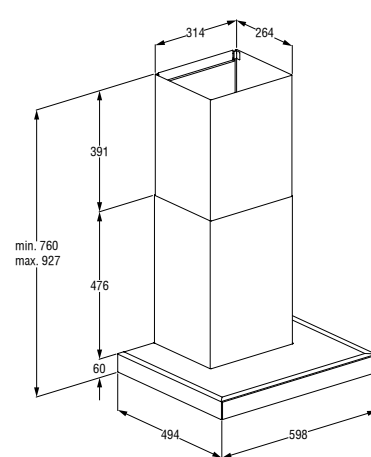

SAP CODE

BHCB66741BBHS

60cm Wall Mounted Cooker Hood

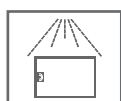
Automatic
shut-offDishwasher-
safe Filters

Touch Control

FUNCTIONS

- Colour: Inox
- Hood Type: Wall-mounted
- Intensive Ventilation
- Air-cleaning Mode
- Auto Shut-down
- Touch control
- Number of Light Bulbs: 2
- Light Bulb Power (W): 3

TECHNOLOGIES

- Filter Saturation Indicator
- Dishwasher-safe Filters
- Carbon Filters
- Number of Grease Filters: 2

PERFORMANCE & CONSUMPTION

- Maximum Ventilation Capacity (m³/h): 425 cu meters/hour
- Minimum Ventilation Capacity (m³/h): 204 cu meters/hour
- Intensive Ventilation Capacity (m³/h): 710 cu meters/hour
- Minimum Ventilation Noise Level (dBA): 43 dBA
- Maximum Ventilation Noise Level (dBA): 60 dBA
- Intensive Ventilation Noise Level (dBA): 71 dBA

Dimensions

- H x W x D: 102.5 x 59.8 x 50.5 cm

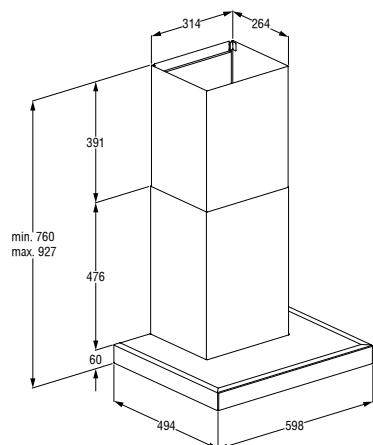

SAP CODE

7703331118

CWB 9441 XN

90cm Wall Mounted Pyramid Cooker Hood

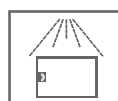
Dishwasher-
safe Filters**Main Features**

- Color - Inox
- Maximum ventilation capacity: 400 cu meters/hour
- Maximum sound power level: 64 dBA
- Mechanical Control - Mechanical Control
- Illumination Type: LED
- Number of Motors: 1
- Number of Grease Filters: 3
- No. of Power Levels: 3
- Type Of Grease Filters: Metal - Cassette
- Dishwasher Safe Filters
- Charcoal Filter: Optional

Efficiency Ratings

- Overall Energy Efficiency Class: E
- Fluid Dynamics Efficiency Class: E
- Lighting Efficiency Class: G
- Grease Filtering Efficiency Class: C
- Average energy consumption per year: 106.0 KW

Dimensions

- H x W x D: 48.0 x 90.0 x 27.0 cm

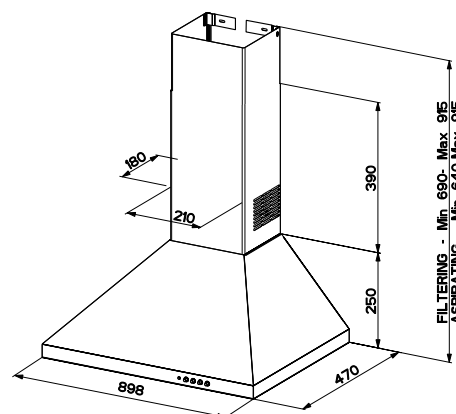

SAP CODE

8891303200

CWB6441XN

60cm Wall Mounted Pyramid Cooker Hood

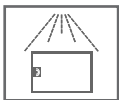

Dishwasher-safe Filters

Main Features

- Color - Inox
- Maximum ventilation capacity: 400 cu meters/hour
- Maximum sound power level: 64 dBA
- Mechanical Control - Mechanical Control
- Illumination Type: Halogen
- Number of Motors: 1
- Number of Grease Filters: 2
- No. of Power Levels: 3
- Type Of Grease Filters: Metal - Cassette
- Dishwasher Safe Filters
- Charcoal Filter

Efficiency Ratings

- Overall Energy Efficiency Class: E
- Fluid Dynamics Efficiency Class: E
- Lighting Efficiency Class: G
- Grease Filtering Efficiency Class: C
- Average energy consumption per year: 106.0 KW

Dimensions

- H x W x D: 74.0 x 59.8 x 49.0 cm

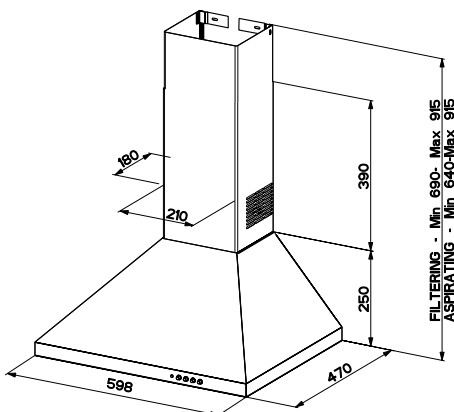

SAP CODE

8866623200

CTB 9250 BB

90 cm Standard Hood

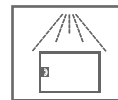

Dishwasher-safe Filters

Main Features

- Color - Black
- Maximum ventilation capacity: 420 cu meters/hour
- Maximum sound power level: 69 dBA
- Mechanical Control - Mechanical Control
- Illumination Type: LED
- Number of Motors: 1
- Number of Grease Filters: 2
- No. of Power Levels: 3
- Type Of Grease Filters: Metal - Cassette
- Dishwasher Safe Filters
- Charcoal Filter

Efficiency Ratings

- Overall Energy Efficiency Class: D
- Fluid Dynamics Efficiency Class: E
- Lighting Efficiency Class: D
- Grease Filtering Efficiency Class: C
- Average energy consumption per year: 88.4KW

Dimensions

- Unit H x W x D: 18.0 x 89.8 x 28.0cm

SAP CODE

CTB 6250 BB

60 cm Standard Hood

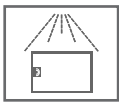

Dishwasher-safe Filters

Main Features

- Color - Black
- Maximum ventilation capacity: 420 cu meters/hour
- Maximum sound power level: 69 dBA
- Mechanical Control - Mechanical Control
- Illumination Type: LED
- Number of Motors: 1
- Number of Grease Filters: 2
- No. of Power Levels: 3
- Type Of Grease Filters: Metal - Cassette
- Dishwasher Safe Filters
- Charcoal Filter

Efficiency Ratings

- Overall Energy Efficiency Class: D
- Fluid Dynamics Efficiency Class: E
- Lighting Efficiency Class: D
- Grease Filtering Efficiency Class: C
- Average energy consumption per year: 88.4KW

Dimensions

- Unit H x W x D: 30.0 x 60.0 x 20.0cm

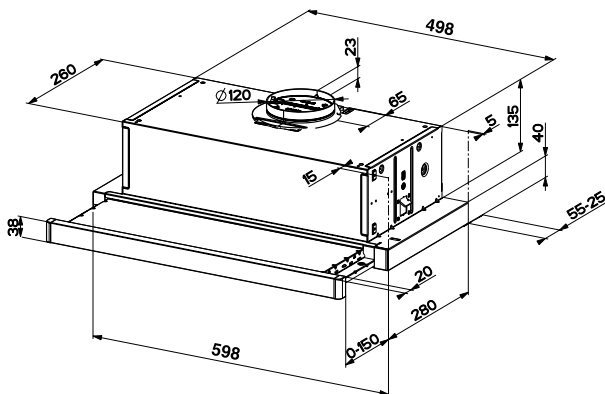

SAP CODE

9210093200

CTB 9250 XH

90 cm Standard Hood

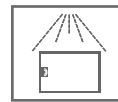
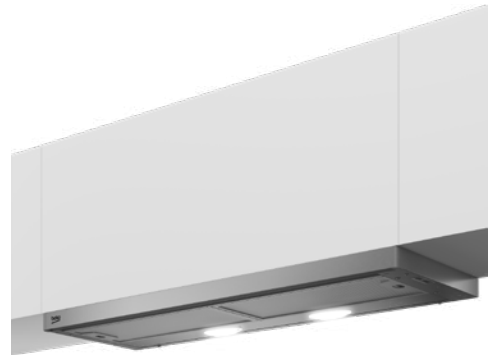

Dishwasher-safe Filters

Main Features

- Color - Inox
- Maximum ventilation capacity: 420 cu meters/hour
- Maximum sound power level: 69 dBA
- Mechanical Control - Mechanical Control
- Illumination Type: LED
- Number of Motors: 1
- Number of Grease Filters: 2
- No. of Power Levels: 3
- Type Of Grease Filters: Metal - Cassette
- Dishwasher Safe Filters
- Charcoal Filter

Efficiency Ratings

- Overall Energy Efficiency Class: D
- Fluid Dynamics Efficiency Class: E
- Lighting Efficiency Class: D
- Grease Filtering Efficiency Class: C
- Average energy consumption per year: 88.4KW

Dimensions

- Unit H x W x D: 18.0 x 89.8 x 28.0cm

Performance

- Voltage (v) 220-240
- Frequency (Hz) 50/60

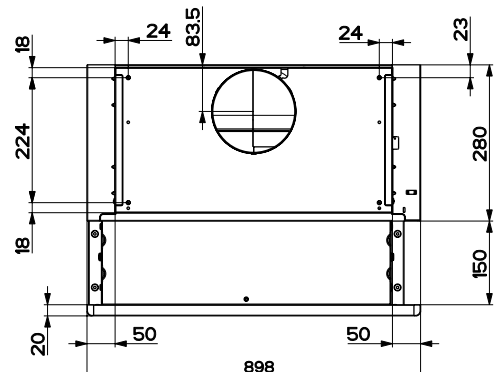

SAP CODE

9210103200

CTB 6250 XH

60 cm Standard Hood

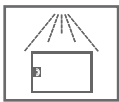

Dishwasher-safe Filters

Main Features

- Color - Inox
- Maximum ventilation capacity: 420 cu meters/hour
- Maximum sound power level: 69 dBA
- Mechanical Control - Mechanical Control
- Illumination Type: LED
- Number of Motors: 1
- Number of Grease Filters: 2
- No. of Power Levels: 3
- Type Of Grease Filters: Metal - Cassette
- Dishwasher Safe Filters
- Charcoal Filter

Efficiency Ratings

- Overall Energy Efficiency Class: D
- Fluid Dynamics Efficiency Class: E
- Lighting Efficiency Class: D
- Grease Filtering Efficiency Class: C
- Average energy consumption per year: 88.4kW

Dimensions

- Unit H x W x D:
30.0 x 60.0 x 20.0cm

Performance

- Voltage (v) 220-240
- Frequency (Hz) 50/60

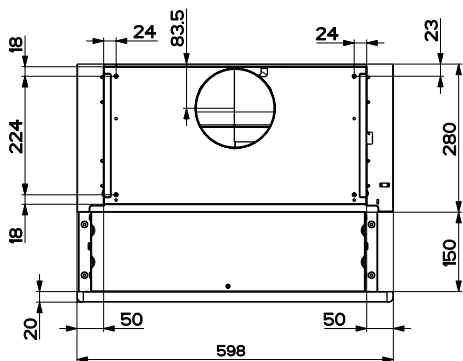

SAP CODE

9210093200



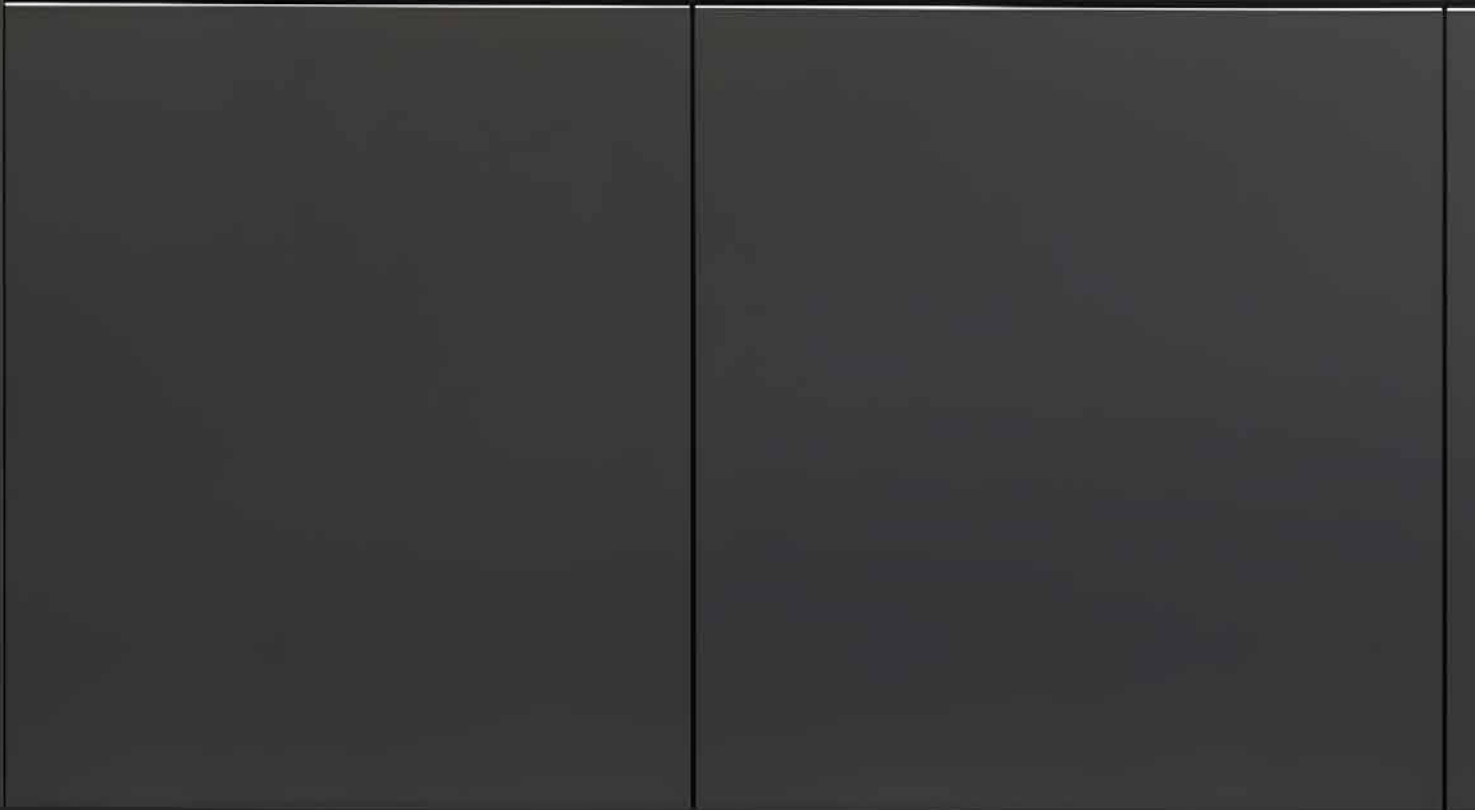



15 13

beig



beko



www.beko.com/gulf/ae-en