

Built-in Oven

User manual

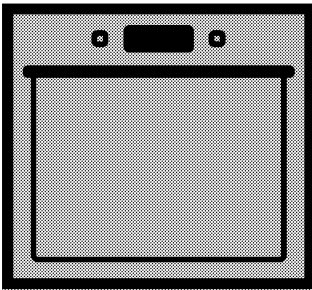

BIM22300X

EN | DE | PT

285.4476.41/R.AA/24.04.2019/5-1
7754886702

Please read this user manual first!

Dear Customer,

Thank you for purchasing this Beko product. We hope that you get the best results from your product which has been manufactured with high quality and state-of-the-art technology. Therefore, please read this entire user manual and all other accompanying documents carefully before using the product and keep it as a reference for future use. If you handover the product to someone else, give the user manual as well. Follow all warnings and information in the user manual.

Remember that this user manual is also applicable for several other models. Differences between models will be identified in the manual.

Explanation of symbols

Throughout this user manual the following symbols are used:

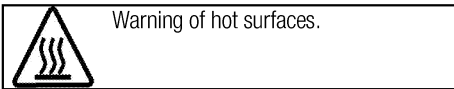
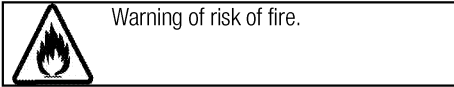
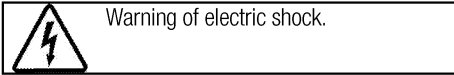
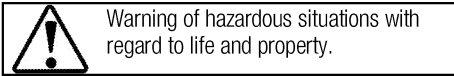
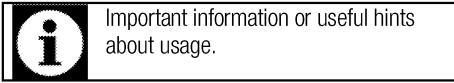

Arçelik A.Ş.
Karaağaç caddesi No:2-6
34445 Sütlüce/Istanbul/TURKEY
Made in TURKEY



This product was manufactured using the latest technology in environmentally friendly conditions.

**1 Important instructions and warnings
for safety and environment 4**

General safety 4
 Electrical safety 4
 Product safety 5
 Intended use 7
 Safety for children 7
 Disposing of the old product 8
 Package information 8
 Future Transportation 8

2 General information 9

Overview 9
 Package contents 10
 Technical specifications 11

3 Installation 12

Before installation 12
 Installation and connection 14

4 Preparation 16

Tips for saving energy 16
 Initial use 16
 Time setting 16
 First cleaning of the appliance 16
 Initial heating 16

5 How to operate the oven 18

General information on baking, roasting and grilling 18
 How to operate the electric oven 18
 Operating modes 19
 Using the oven clock 19
 Cooking times table 21
 How to operate the grill 24
 Cooking times table for grilling 24

6 Maintenance and care 25

General information 25
 Cleaning the control panel 25
 Cleaning the oven 25
 Removing the oven door 26
 Removing the door inner glass 26
 Replacing the oven lamp 27

7 Troubleshooting 29

1 Important instructions and warnings for safety and environment

This section contains safety instructions that will help protect from risk of personal injury or property damage. Failure to follow these instructions shall void any warranty.

General safety

- This appliance can be used by children aged from 8 years and above and persons with reduced physical, sensory or mental capabilities or lack of experience and knowledge if they have been given supervision or instruction concerning use of the appliance in a safe way and understand the hazards involved.
Children shall not play with the appliance. Cleaning and user maintenance shall not be made by children without supervision.
- The appliance is not to be used by persons (including children) with reduced physical, sensory or mental capabilities, or lack of experience and knowledge, unless they have been given supervision or instruction.
Children should be supervised and ensure they do not play with the appliance
- If the product is handed over to someone else for personal use or second-hand use purposes, the

user manual, product labels and other relevant documents and parts should be also given.

- Installation and repair procedures must always be performed by Authorised Service Agents. The manufacturer shall not be held responsible for damages arising from procedures carried out by unauthorised persons which may also void the warranty. Before installation, read the instructions carefully.
- Do not operate the product if it is defective or has any visible damage.
- Ensure that the product function knobs are switched off after every use.

Electrical safety

- If the product has a failure, it should not be operated unless it is repaired by an Authorised Service Agent. There is the risk of electric shock!
- Only connect the product to a grounded outlet/line with the voltage and protection as specified in the “Technical specifications”. Have the grounding installation made by a qualified electrician while using the product with or without a

transformer. Our company shall not be liable for any problems arising due to the product not being earthed in accordance with the local regulations.

- Never wash the product by spreading or pouring water onto it! There is the risk of electric shock!
- Never touch the plug with wet hands! Never unplug by pulling on the cable, always pull out by holding the plug.
- The product must be disconnected during installation, maintenance, cleaning and repairing procedures.
- If the power connection cable for the product is damaged, it must be replaced by the manufacturer, its service agent or similarly qualified persons in order to avoid a hazard.
- The appliance must be installed so that it can be completely disconnected from the mains supply. The separation must be provided by a switch built into the fixed electrical installation, according to construction regulations.
- Rear surface of the oven gets hot when it is in use. Make sure that the electrical connection does not contact the rear surface; otherwise, connections can get damaged.

- Do not trap the mains cable between the oven door and frame and do not route it over hot surfaces. Otherwise, cable insulation may melt and cause fire as a result of short circuit.
- Any work on electrical equipment and systems should only be carried out by authorised and qualified persons.
- In case of any damage, switch off the product and disconnect it from the mains. To do this, turn off the fuse at home.
- Make sure that fuse rating is compatible with the product.

Product safety

- **WARNING:** The appliance and its accessible parts become hot during use. Care should be taken to avoid touching heating elements. Children less than 8 years of age shall be kept away unless continuously supervised.
- Never use the product when your judgment or coordination is impaired by the use of alcohol and/or drugs.
- Be careful when using alcoholic drinks in your dishes. Alcohol evaporates at high temperatures and may cause fire since it can ignite when it comes into contact with hot surfaces.
- **Food Poisoning Hazard:** Do not let food sit in oven for more than 1

hour before or after cooking. Doing so can result in food poisoning or sickness.

- Do not place any flammable materials close to the product as the sides may become hot during use.
- During use the appliances becomes hot. Care should be taken to avoid touching heating elements inside the oven.
- Keep all ventilation slots clear of obstructions.
- Do not heat closed tins and glass jars in the oven. The pressure that would build-up in the tin/jar may cause it to burst.
- Do not place baking trays, dishes or aluminium foil directly onto the bottom of the oven. The heat accumulation might damage the bottom of the oven.
- Do not use harsh abrasive cleaners or sharp metal scrapers to clean the oven door glass since they can scratch the surface, which may result in shattering of the glass.
- Do not use steam cleaners to clean the appliance as this may cause an electric shock.
- (Varies depending on the product model.)
Placing the wire shelf and tray onto the wire racks properly

It is important to place the wire shelf and/or tray onto the rack properly. Slide the wire shelf or tray between 2 rails and make sure that it is balanced before placing food on it (Please see the following figure).

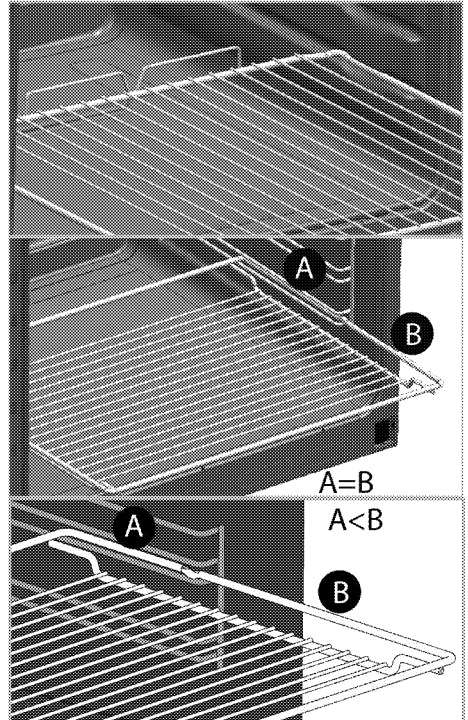

- Do not use the product if the front door glass removed or cracked.
- Do not use the oven handle to hang towels for drying. Do not hang up towel, gloves, or similar textile products when the grill function is at open door.
- Always use heat resistant oven gloves when putting in or removing dishes into/from the hot oven.

- Place the baking paper into the cooking pot or on to the oven accessory (tray, wire grill etc) together with the food and then insert all into the preheated oven. Remove the excess parts of the baking paper overflowing from the accessory or the pot in order to prevent the risk of touching the oven's heating elements. Never use the baking paper in an operating temperature higher than the indicated value for the baking paper. Do not place the baking paper directly on the base of the oven.
- **WARNING:** Ensure that power cord of the appliance is unplugged or circuit breaker is switched off before replacing the lamp to avoid the possibility of electric shock.
- The appliance must not be installed behind a decorative door in order to avoid overheating.

Prevention against possible fire risk!

- Ensure all electrical connections are secure and tight to prevent risk of arcing.
- Do not use damaged cables or extension cables.
- Ensure liquid or moisture is not accessible to the electrical connection point.

Intended use

- This product is designed for domestic use. Commercial use will void the guarantee.
- **CAUTION:** This appliance is for cooking purposes only. It must not be used for other purposes, for example room heating.
- This product should not be used for warming the plates under the grill, drying towels, dish cloths etc. by hanging them on the oven door handles. This product should also not be used for room heating purposes.
- The manufacturer shall not be liable for any damage caused by improper use or handling errors.
- The oven can be used for defrosting, baking, roasting and grilling food.

Safety for children

- **WARNING:** Accessible parts may become hot during use. Young children should be kept away.
- The packaging materials will be dangerous for children. Keep the packaging materials away from children. Please dispose of all parts of the packaging according to environmental standards.
- Electrical products are dangerous to children. Keep children away from the product when it is operating and do not allow them to play with the product.

- Do not place any items above the appliance that children may reach for.
- When the door is open, do not load any heavy object on it and do not allow children to sit on it. It may overturn or door hinges may get damaged.

Disposing of the old product

Compliance with the WEEE Directive and Disposing of the Waste Product:



This product complies with EU WEEE Directive (2012/19/EU). This product bears a classification symbol for waste electrical and electronic equipment (WEEE).

This product has been manufactured with high quality parts and materials which can be reused and are suitable for recycling. Do not dispose of the waste product with normal domestic and other wastes at the end of its service life. Take it to the collection center for the recycling of electrical and electronic equipment. Please consult your local authorities to learn about these collection centers.

Compliance with RoHS Directive:

The product you have purchased complies with EU RoHS Directive (2011/65/EU). It does not contain harmful and prohibited materials specified in the Directive.

Package information

- Packaging materials of the product are manufactured from recyclable materials in accordance with our National Environment Regulations. Do not dispose of the packaging materials together with the domestic or other wastes. Take them to the packaging material collection points designated by the local authorities.

Future Transportation

- Keep the product's original carton and transport the product in it. Follow the instructions on the carton. If you do not have the original carton, pack the product in bubble wrap or thick cardboard and tape it securely.
- To prevent the wire grill and tray inside the oven from damaging the oven door, place a strip of cardboard onto the inside of the oven door that lines up with the position of the trays. Tape the oven door to the side walls.
- Do not use the door or handle to lift or move the product.



Do not place any objects onto the product and move it in upright position.



Check the general appearance of your product for any damages that might have occurred during transportation.

2 General information

Overview

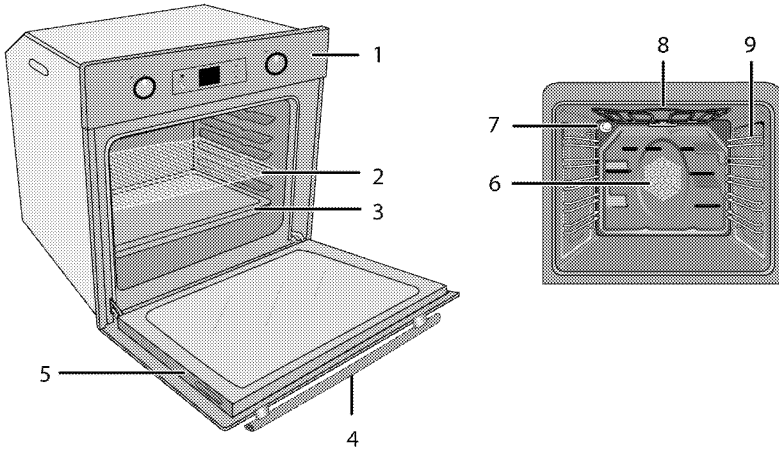

- 1 Control panel
- 2 Wire shelf
- 3 Tray
- 4 Handle
- 5 Door

- 6 Fan motor (behind steel plate)
- 7 Lamp
- 8 Top heating element
- 9 Shelf positions

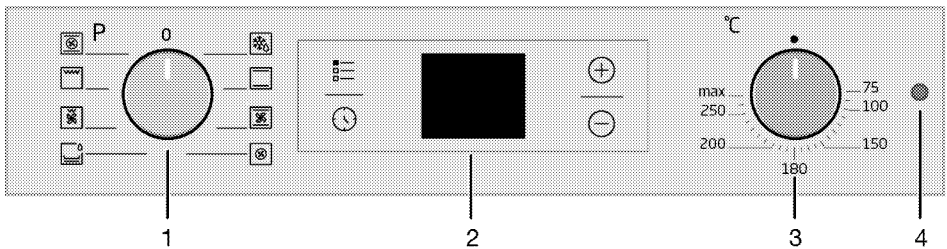

- 1 Function knob
- 2 Digital timer

- 3 Thermostat knob
- 4 Thermostat lamp

Package contents



Accessories supplied can vary depending on the product model. Not every accessory described in the user manual may exist on your product.

1. **User manual**

2. **Standard tray**

Used for pastries, frozen foods and big roasts.

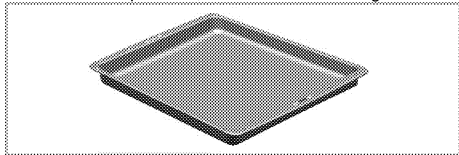

3. **Pastry tray**

Used for pastries such as cookies and biscuits.

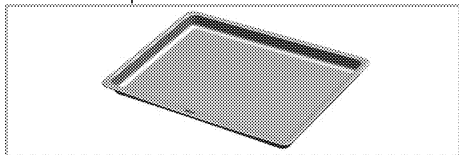

4. **Wire grill**

Used for roasting and for placing the food to be baked, roasted or cooked in casserole dishes to the desired rack.

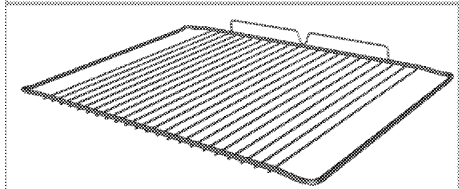
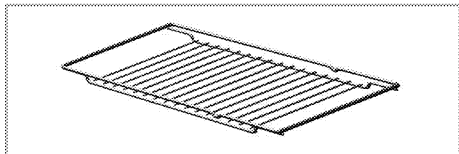

5. **Placing the wire shelf and tray onto the telescopic racks properly**
(This feature is optional. It may not exist on your product.)

Telescopic racks allow you to install and remove the trays and wire shelf easily.

When using the tray and wire shelf with telescopic racks, make sure that the pins at the rear section of the telescopic rack stands against the edges of the wire shelf and tray.

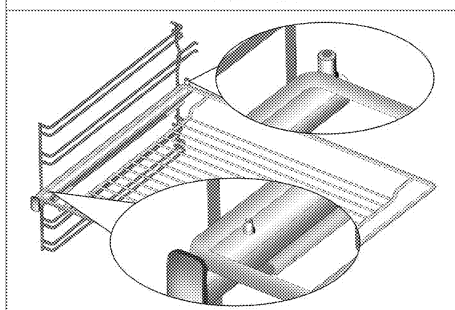
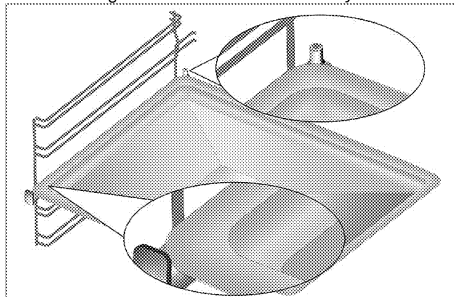

Technical specifications

Voltage / frequency	220-240 V ~ 50 Hz
Total power consumption	2.5 kW
Cable type / section	min.H05W-FG 3 x 1,5 mm ²
External dimensions (height / width / depth)	595 mm/594 mm/567 mm
Installation dimensions (height / width / depth)	**590 or 600 mm/560 mm/min. 550 mm
Main oven	Multifunction oven
Inner lamp	15/25 W
Grill power consumption	2.2 kW

Basics: Information on the energy label of electrical ovens is given in accordance with the EN 60350-1 / IEC 60350-1 standard. Those values are determined under standard load with bottom-top heater or fan assisted heating (if any) functions.

Energy efficiency class is determined in accordance with the following prioritization depending on whether the relevant functions exist on the product or not. 1-Cooking with eco-fan, 2- Turbo slow cooking, 3- Turbo cooking, 4- Fan assisted bottom/top heating, 5-Top and bottom heating.

** See. *Installation, page 12.*



Technical specifications may be changed without prior notice to improve the quality of the product.



Figures in this manual are schematic and may not exactly match your product.



Values stated on the product labels or in the documentation accompanying it are obtained in laboratory conditions in accordance with relevant standards. Depending on operational and environmental conditions of the product, these values may vary.

3 Installation

Product must be installed by a qualified person in accordance with the regulations in force. The manufacturer shall not be held responsible for damages arising from procedures carried out by unauthorized persons which may also void the warranty.



Preparation of location and electrical installation for the product is under customer's responsibility.



DANGER:

The product must be installed in accordance with all local electrical regulations.



DANGER:

Prior to installation, visually check if the product has any defects on it. If so, do not have it installed.

Damaged products cause risks for your safety.

Before installation

The appliances must not be installed behind a decorative door in order to avoid overheating. The appliance is intended for installation in commercially available kitchen cabinets. A safety distance must be left between the appliance and the kitchen walls and furniture. See figure (values in mm).

- Surfaces, synthetic laminates and adhesives used must be heat resistant (100 °C minimum).
- Kitchen cabinets must be set level and fixed.
- If there is a drawer beneath the oven, a shelf must be installed in order to separate from the oven and drawer.
- Carry the appliance with at least two persons.
- Hold the oven from the slots for handling on both sides to move it.
- Before installing the product, remove all materials and documents inside.
- Kitchen furniture must be in compliance with the dimensions given in the figure below. At the rear section of the kitchen furniture, an opening must be cut out with the dimensions given in the figure below to ensure sufficient ventilation.



Do not install the appliance next to refrigerators or freezers. The heat emitted by the appliance will lead to an increased energy consumption of cooling appliances.



The door and/or handle must not be used for lifting or moving the appliance.

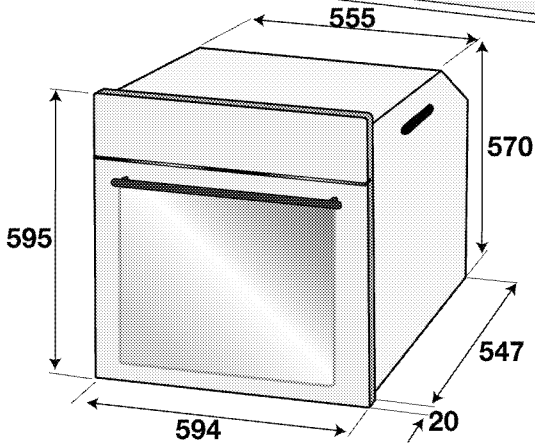
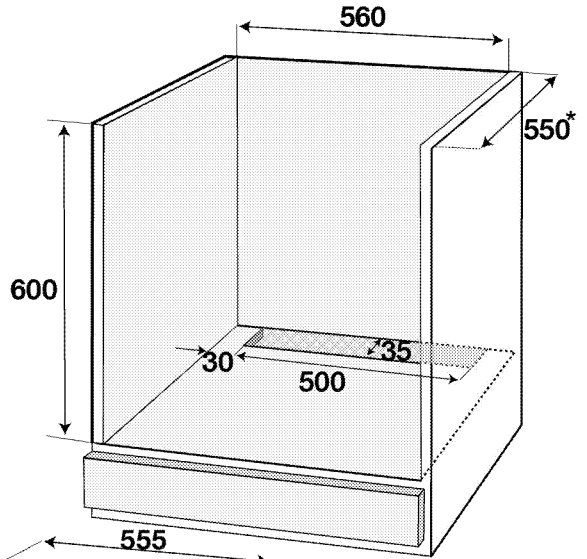
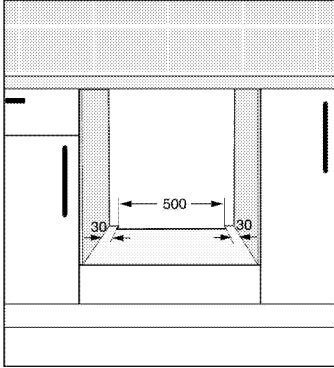
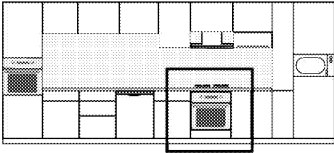

* min.

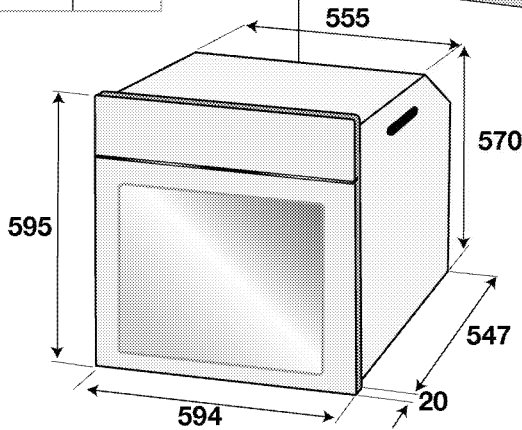
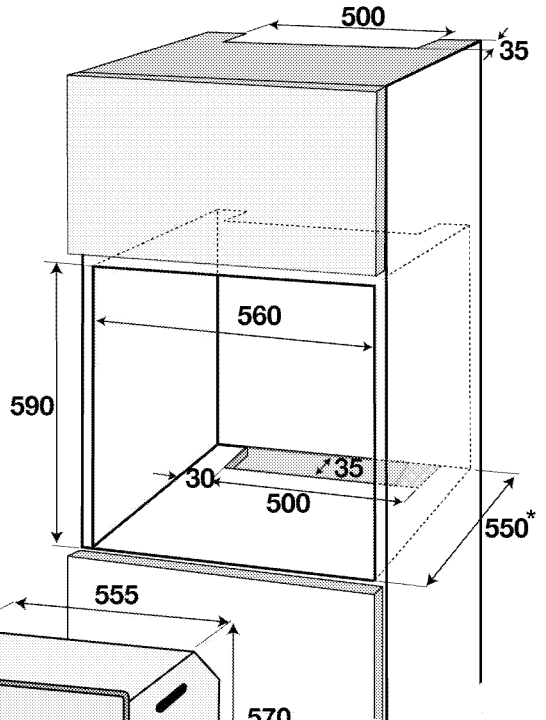
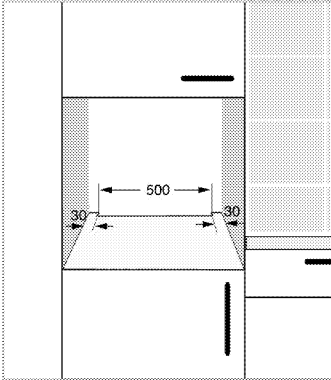
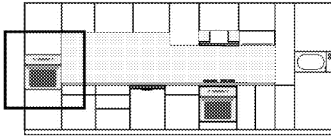

* min.

Installation and connection

- The product must be installed in accordance with all local gas and electrical regulations.

Electrical connection

Connect the product to a grounded outlet/line protected by a miniature circuit breaker of suitable capacity as stated in the "Technical specifications" table. Have the grounding installation made by a qualified electrician while using the product with or without a transformer. Our company shall not be liable for any damages that will arise due to using the

product without a grounding installation in accordance with the local regulations.



DANGER:

The product must be connected to the mains supply only by an authorised and qualified person. The product's warranty period starts only after correct installation. Manufacturer shall not be held responsible for damages arising from procedures carried out by unauthorised persons.

**DANGER:**

The power cable must not be clamped, bent or trapped or come into contact with hot parts of the product.

A damaged power cable must be replaced by a qualified electrician. Otherwise, there is risk of electric shock, short circuit or fire!

- Connection must comply with national regulations.
- The mains supply data must correspond to the data specified on the type label of the product. Open the front door to see the type label.
- Power cable of your product must comply with the values in "Technical specifications" table.

**DANGER:**

Before starting any work on the electrical installation, disconnect the product from the mains supply.

There is the risk of electric shock!



Power cable plug must be within easy reach after installation (do not route it above the hob).



While performing the wiring, you must apply with the national/local electrical regulations and must use the appropriate socket outlet/line and plug for oven. In case of the product's power limits are out of current carrying capability of plug and socket outlet/line, the product must be connected through fixed electrical installation directly without using plug and socket outlet/line.

Plug the power cable into the socket.

Installing the product

1. Slide the oven into the cabinet, align and secure it while making sure that the power cable is not broken and/or trapped.

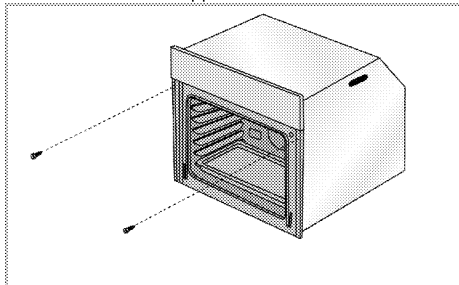

Secure the oven with 2 screws as illustrated.

After the installation, make sure that the screws are sufficiently tightened and the oven does not move. Oven may tip over during use if it is not installed as per the instructions and if the screws are not sufficiently tightened.

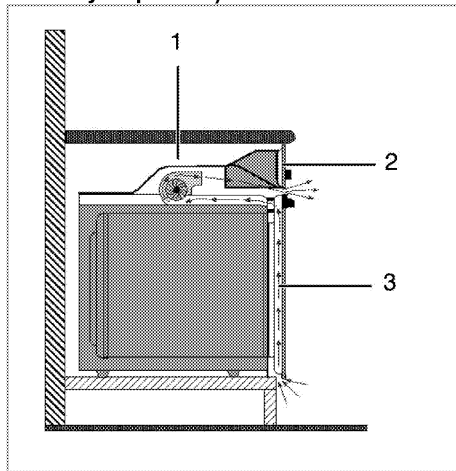
For products with cooling fan (This may not exist on your product.)

- 1 Cooling fan
- 2 Control panel
- 3 Door

The built-in cooling fan cools both the built-in cabinet and the front of the product.



Cooling fan continues to operate for about 20-30 minutes after the oven is switched off.

If you have cooked by programming the timer of the oven, cooling fan will also be switched off at the end of the cooking time together with all functions.

Final check

1. Operate the product.
2. Check the functions.

4 Preparation

Tips for saving energy

The following information will help you to use your appliance in an ecological way, and to save energy:

- Use dark coloured or enamel coated cookware in the oven since the heat transmission will be better.
- While cooking your dishes, perform a preheating operation if it is advised in the user manual or cooking instructions.
- Do not open the door of the oven frequently during cooking.
- Try to cook more than one dish in the oven at the same time whenever possible. You can cook by placing two cooking vessels onto the wire shelf.
- Cook more than one dish one after another. The oven will already be hot.
- You can save energy by switching off your oven a few minutes before the end of the cooking time. Do not open the oven door.
- Defrost frozen dishes before cooking them.

Initial use

Time setting



While making any adjustment, related symbols will flash on the display.

Press (+)/(-) keys to set the time of the day after the oven is energized for the first time.



For touch control models, touch  first and then use (+) / (-) to set the time of the day.

Confirm the setting by touching  symbol and wait for 4 seconds without touching any keys to confirm.

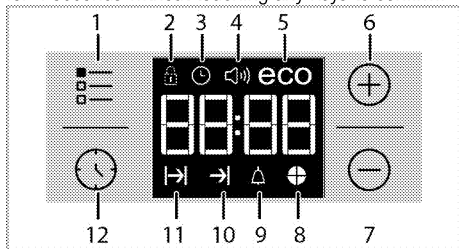

- 1 Adjustment key
- 2 Keylock symbol
- 3 Clock symbol
- 4 Alarm volume symbol (This may not exist on your product.)

- 5 Eco mode symbol
- 6 Plus key
- 7 Minus key
- 8 Time slice symbol
- 9 Alarm symbol
- 10 End of Cooking Time symbol
- 11 Cooking Time symbol
- 12 Program key



If the initial time is not set, clock will run starting from 12:00 and  symbol will be displayed. The symbol will disappear once the time is set.



Current time settings are canceled in case of power failure. It needs to be readjusted.

First cleaning of the appliance



The surface might get damaged by some detergents or cleaning materials.

Do not use aggressive detergents, cleaning powders/creams or any sharp objects during cleaning.

Do not use harsh abrasive cleaners or sharp metal scrapers to clean the oven door glass since they can scratch the surface, which may result in shattering of the glass.

1. Remove all packaging materials.
2. Wipe the surfaces of the appliance with a damp cloth or sponge and dry with a cloth.

Initial heating

Heat up the product for about 30 minutes and then switch it off. Thus, any production residues or layers will be burnt off and removed.



WARNING

Hot surfaces cause burns!

Product may be hot when it is in use. Never touch the hot burners, inner sections of the oven, heaters and etc. Keep children away. Always use heat resistant oven gloves when putting in or removing dishes into/from the hot oven.

Electric oven

1. Take all baking trays and the wire grill out of the oven.
2. Close the oven door.
3. Select Static position.

4. Select the highest oven power; See *How to operate the electric oven, page 18*.
5. Operate the oven for about 30 minutes.
6. Turn off your oven; See *How to operate the electric oven, page 18*

Grill oven

1. Take all baking trays and the wire grill out of the oven.
2. Close the oven door.
3. Select the highest grill power; see *How to operate the grill, page 24*.
4. Operate the grill about 30 minutes.
5. Turn off your grill; see *How to operate the grill, page 24*



Smoke and smell may emit for a couple of hours during the initial operation. This is quite normal. Ensure that the room is well ventilated to remove the smoke and smell. Avoid directly inhaling the smoke and the smell that emits.

5 How to operate the oven

General information on baking, roasting and grilling



WARNING
Hot surfaces cause burns!
Product may be hot when it is in use. Never touch the hot burners, inner sections of the oven, heaters and etc. Keep children away. Always use heat resistant oven gloves when putting in or removing dishes into/from the hot oven.



DANGER:
Be careful when opening the oven door as steam may escape.
Exiting steam can scald your hands, face and/or eyes.

Tips for baking

- Use non-sticky coated appropriate metal plates or aluminum vessels or heat-resistant silicone moulds.
- Make best use of the space on the rack.
- Place the baking mould in the middle of the shelf.
- Select the correct rack position before turning the oven or grill on. Do not change the rack position when the oven is hot.
- Keep the oven door closed.

Tips for roasting

- Treating whole chicken, turkey and large piece of meat with dressings such as lemon juice and black pepper before cooking will increase the cooking performance.
- It takes about 15 to 30 minutes longer to roast meat with bones when compared to roasting the same size of meat without bones.
- Each centimeter of meat thickness requires approximately 4 to 5 minutes of cooking time.
- Let meat rest in the oven for about 10 minutes after the cooking time is over. The juice is better distributed all over the roast and does not run out when the meat is cut.
- Fish should be placed on the middle or lower rack in a heat-resistant plate.

Tips for grilling

When meat, fish and poultry are grilled, they quickly get brown, have a nice crust and do not get dry. Flat pieces, meat skewers and sausages are particularly suited for grilling as are vegetables with high water content such as tomatoes and onions.

- Distribute the pieces to be grilled on the wire shelf or in the baking tray with wire shelf in such

a way that the space covered does not exceed the size of the heater.

- Slide the wire shelf or baking tray with grill into the desired level in the oven. If you are grilling on the wire shelf, slide the baking tray to the lower rack to collect fats. Add some water in the tray for easy cleaning.



Foods that are not suitable for grilling carry the risk of fire. Only grill food which is suitable for intensive grilling heat.
Do not place the food too far in the back of the grill. This is the hottest area and fatty food may catch fire.

How to operate the electric oven

Select temperature and operating mode

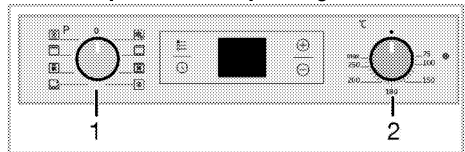

1 Function knob

2 Thermostat knob

1. Set the Function knob to the desired operating mode.
2. Set the Temperature knob to the desired temperature.

» Oven heats up to the adjusted temperature and maintains it. During heating, temperature lamp stays on.

Switching off the electric oven

Turn the function knob and temperature knob to off (upper) position.

Rack positions (For models with wire shelf)

It is important to place the wire shelf onto the side rack correctly. Wire shelf must be inserted between the side racks as illustrated in the figure.

Do not let the wire shelf stand against the rear wall of the oven. Slide your wire shelf to the front section of the rack and settle it with the help of the door in order to obtain a good grill performance.
(Varies depending on the product model.)

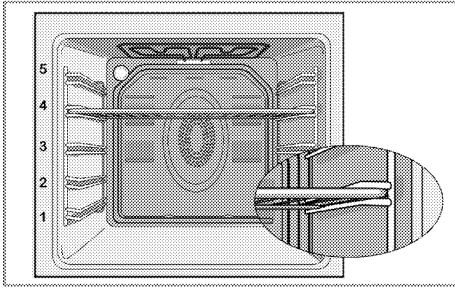

Operating modes

The order of operating modes shown here may be different from the arrangement on your product.

Top and bottom heating



Top and bottom heating are in operation. Food is heated simultaneously from the top and bottom. For example, it is suitable for cakes, pastries, or cakes and casseroles in baking moulds. Cook with one tray only.

Bottom heating



Only bottom heating is in operation. It is suitable for pizza and for subsequent browning of food from the bottom.



This function must be used for easy steam cleaning as well.

Fan supported bottom/top heating



Top heating, bottom heating plus fan (in the rear wall) are in operation. Hot air is evenly distributed throughout the oven rapidly by means of the fan. Cook with one tray only.

Operating with fan



The oven is not heated. Only the fan (in the rear wall) is in operation. Suitable for thawing frozen granular food slowly at room temperature and cooling down the cooked food.

Fan Heating



Warm air heated by the rear heater is evenly distributed throughout the oven rapidly by means of the fan.



It is suitable for cooking your meals in different rack levels and preheating is not required in most cases. Suitable for cooking with multi trays.

This function must be used for easy steam cleaning as well.

"3D" function



Top heating, bottom heating and fan assisted heating (in the rear wall) are in operation. Food is cooked evenly and quickly all around. Cook with one tray only.

Full grill



Large grill at the ceiling of the oven is in operation. It is suitable for grilling large amount of meat.

- Put big or medium-sized portions in correct rack position under the grill heater for grilling.
- Set the temperature to maximum level.
- Turn the food after half of the grilling time.

Grill+Fan



Grilling effect is not as strong as in Full Grill



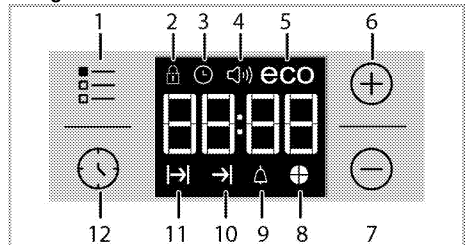

- Put small or medium-sized portions in correct shelf position under the grill heater for grilling.
- Set the desired temperature.
- Turn the food after half of the grilling time.

Using the oven clock





- 1 Adjustment key
- 2 Keylock symbol

- 3 Clock symbol
- 4 Alarm volume symbol (This may not exist on your product.)
- 5 Eco mode symbol
- 6 Plus key
- 7 Minus key
- 8 Time slice symbol
- 9 Alarm symbol
- 10 End of Cooking Time symbol
- 11 Cooking Time symbol
- 12 Program key

	Maximum time that can be set for end of cooking is 5 hours 59 minutes. Program will be cancelled in case of power failure. You must reprogram the oven.
	While making any setting, related symbols will flash on the display. You must wait for a short time for the settings to take effect.
	If no cooking setting is made, time of the day cannot be set.
	Remaining time will be displayed if cooking time is set when the cooking starts.

Cooking by setting the cooking time;

You can set the oven so that it will stop at the end of the specified time by setting the cooking time on the timer.







1. Select the function for cooking.
2. Touch  until  symbol appears on display for cooking time.
3. Set the cooking time with \oplus / \ominus keys.
» » After the cooking time is set,  symbol and the time slice will appear on display continuously.
4. Place the dish into the oven and set the temperature with temperature knob. Cooking will start.

» Cooking time starts to count down on display when cooking starts and all parts of time slice symbol is lit. The set cooking time is divided into 4 equal parts and when the time of each parts ends, the symbol of that parts turns off. So you can understand the ratio of remaining cooking time to total cooking time easily.

Setting the the end of cooking time to a later time;

After setting the cooking time on the timer, you can set the end of cooking time to a later time.

1. Select the function for cooking.
2. Touch  until  symbol appears on display for cooking time.

3. Set the cooking time with \oplus / \ominus keys.
» » Once the Cooking Time is set,  symbol will appear on display continuously.
4. Touch  until  symbol appears on display for the end of cooking time.
5. Press \oplus / \ominus keys to set the end of cooking time.
» After the cooking time is set,  symbol plus  symbol and the time slice will appear on display continuously. Once the cooking starts,  symbol disappears.
6. Place the dish into the oven and set the temperature with temperature knob. Cooking will start.

» **Oven timer calculates the startup time by deducting the cooking time from the end of cooking time you have set.** Selected operating mode is activated when the startup time of cooking has come and the oven is heated up to the set temperature. It maintains this temperature until the end of cooking time.



» Cooking time starts to count down on display when cooking starts and all parts of time slice symbol is lit. The set cooking time is divided into 4 equal parts and when the time of each parts ends, the symbol of that parts turns off. So you can understand the ratio of remaining cooking time to total cooking time easily.

7. After the cooking process is completed, "End" appears on the displayed and the timer gives an audio warning.
8. Audio warning sounds for 2 minutes. To stop the audio warning, just press any key. Audio warning will be silenced and current time will be displayed.

	If you press any key at the end of the audio warning, the oven will restart operating. Turn the temperature knob and function knob to "0" (off) position to switch off the oven in order to prevent re-operation of the oven at the end of warning.
--	---



Activating the keylock

You can prevent digital timer from being intervened with by activating the key lock function.

1. Touch  until  symbol appears on display.
» "OFF" will appear on the display.
2. Press \oplus to activate the key lock.
» Once the key lock is activated, "On" appears on the display and the  symbol remains lit.

	Digital timer keys are not functional when the key lock is activated. Key lock will not be cancelled in case of power failure.
---	--

To deactivate the keylock

1. Touch  until  symbol appears on display.
» "On" will appear on the display.
2. Disable the key lock by pressing the  key.
» "OFF" will be displayed once the keylock is deactivated.

Setting the alarm clock

You can use the timer of the product for any warning or reminder apart from the cooking program. The alarm clock has no influence on the functions of the oven. It is only used as a warning. For example, this is useful when you want to turn food in the oven at a certain point of time. Timer will give an audio warning at the end of the set time.

1. Touch  until  symbol appears on display.





Maximum alarm time can be 23 hours and 59 minutes.

2. Set the alarm duration by using  /  keys.





Function keys for alarm tone, time of day, display brightness and temperature keys should be at 0 (OFF) position.

- »  symbol will remain lit and the alarm time will appear on the display once the alarm time is set.
3. At the end of the alarm time,  symbol starts flashing and the audio warning is heard.

Turning off the alarm

1. Audio warning sounds for 2 minutes. To stop the audio warning, just press any key.
- » Audio warning will be silenced and current time will be displayed.





Cancelling the alarm;

1. Touch  until  symbol appears on display in order to cancel the alarm.
2. Press and hold  key until "00:00" is displayed.







Alarm time will be displayed. If the alarm time and cooking time are set concurrently, shortest time will be displayed.

Changing alarm tone

1. Touch  until  symbol appears on display.
 2. Adjust the desired alarm tone with  /  keys.
 3. The tone you have set will be activated in a short time.
- » Selected alarm tone will appear as "b-01", "b-02" or "b-03" on the display.

Changing the time of the day



To change the time of the day you have previously set:

1. Touch  until  symbol appears on display.
2. Set the time of the day with  /  keys.
3. The time you have set will be activated in a short time.



Economy mode

You can save energy with economy mode while cooking by setting cooking time in the oven. This mode completes the cooking with the inner temperature of the oven by switching off the heaters before the end of cooking time.

Setting the economy mode



1. Touch  symbol until **eco** symbol appears on display.
» "OFF" will appear on the display.
2. Enable economy mode by touching  key.
» Once the economy mode is activated, "On" appears on the display and the eco symbol remains lit.

Disabling economy mode

1. Touch  symbol until **eco** symbol appears on display.
» "On" will appear on the display.
2. Disable economy mode by touching  key.
» "Off" will be displayed once the eco mode is deactivated.

Setting the screen brightness

(This feature is optional. It may not exist on your product.)

1. Touch  until **d-01** or **d-02** or **d-03** appears on display for display brightness.
2. Set the desired brightness with  /  keys.
» The time you have set will be activated in a short time.

Cooking times table































The timings in this chart are meant as a guide. Timings may vary due to temperature of food, thickness, type and your own preference of cooking.

Baking and roasting



1st rack of the oven is the **bottom** rack.















Dish	Cooking level number	Accessory to use	Operating mode	Rack position	Temperature (°C)	Cooking time (approx. in min.)
Cakes in tray	One level	Standard tray*		3	180	25 ... 30
Cakes in mould	One level	Cake mold on wire grill**		2	180	40 ... 50

Small cakes	One level	Standard tray*		3	160	25 ... 35
	One level	Standard tray*		3	150	30 ... 40
	2 levels	1-Pastry tray* 3-Standard tray*		1 - 3	150	35 ... 50
	3 levels	1-Standard tray* 3-Pastry tray* 5-Deep tray*		1 - 3 - 5	150	35 ... 50
Sponge cake	One level	Round springform pan with a diameter of 26 cm on wire grill**		3	160	25 ... 35
	One level	Round springform pan with a diameter of 26 cm on wire grill**		2	150	30 ... 40
	2 levels	1-Round springform pan with a diameter of 26 cm on wire grill** 4-Round springform pan with a diameter of 26 cm on pastry tray**		1 - 4	150	35 ... 45
Cookies	One level	Pastry tray*		3	180	25 ... 30
	2 levels	1-Pastry tray* 3-Standard tray*		1 - 3	180	30 ... 40
	3 levels	1-Pastry tray* 3-Standard tray* 5-Deep tray*		1 - 3 - 5	180	35 ... 45
Dough pastry	One level	Standard tray*		2	200	30 ... 40
	2 levels	1-Pastry tray* 5-Standard tray*		1 - 5	200	45 ... 55
	3 levels	1-Pastry tray* 3-Standard tray* 5-Deep tray*		1 - 3 - 5	200	55 ... 65
Rich pastry	One level	Standard tray*		2	200	25 ... 35
	2 levels	1-Pastry tray* 3-Standard tray*		1 - 3	200	35 ... 45
	3 levels	1-Pastry tray* 3-Standard tray* 5-Deep tray*		1 - 3 - 5	190	45 ... 55
Leaven	One level	Standard tray*		2	200	35 ... 45
Lasagna	One level	Glass/metal rectangular pan on wire grill**		2 - 3	200	30 ... 40
Pizza	One level	Standard tray*		2	200 ... 220	15 ... 20
Beef steak (whole) / Roast	One level	Standard tray*		3	25 min. 250/max, then 180 ... 190	100 ... 120
Leg of Lamb (casserole)	One level	Standard tray*		3	25 min. 250/max, then 190	70 ... 90
	One level	Standard tray*		3	25 min. 250/max, then 190	60 ... 80
Roasted chicken (1,8-2 kg)	One level	Standard tray*		2	15 min. 250/max, then 180 ... 190	60 ... 80
	One level	Standard tray*		2	15 min. 250/max, then 180 ... 190	60 ... 80
Turkey (5.5 kg)	One level	Standard tray*		1	25 min. 250/max, then 180 ... 190	150 ... 210
	One level	Standard tray*		1	25 min. 250/max, then 180 ... 190	150 ... 210
Fish	One level	Standard tray*		3	200	20 ... 30

	One level	Standard tray*		3	200	20 ... 30
It is suggested to perform preheating for all foods. * These accessories may not be supplied with the product. ** These accessories are not supplied with the product. They are commercially available accessories.						

Cooking table for test meals

Meals in this cooking table are prepared according to EN 60350-1 to make it easier for control institutes to test the product

Dish	Cooking level number	Accessory to use	Operating mode	Rack position	Temperature (°C)	Cooking time (approx. in min.)
Shortbread	One level	Standard tray*		3	140	20 ... 30
	One level	Standard tray*		3	140	20 ... 30
	2 levels	1-Standard tray* 3-Pastry tray*		1 - 3	140	20 ... 30
	3 levels	1-Standard tray* 3-Pastry tray* 5-Deep tray*		1 - 3 - 5	140	25 ... 35
Small cakes	One level	Standard tray*		3	160	25 ... 35
	One level	Standard tray*		3	150	30 ... 40
	2 levels	1-Pastry tray* 3-Standard tray*		1 - 3	150	35 ... 50
	3 levels	1-Standard tray* 3-Pastry tray* 5-Deep tray*		1 - 3 - 5	150	35 ... 50
Sponge cake	One level	Round springform pan with a diameter of 26 cm on wire grill**		3	160	25 ... 35
	One level	Round springform pan with a diameter of 26 cm on wire grill**		2	150	30 ... 40
	2 levels	1-Round springform pan with a diameter of 26 cm on wire grill** 4-Round springform pan with a diameter of 26 cm on pastry tray**		1 - 4	150	35 ... 45
Apple pie	One level	Round black metal dish with a diameter of 20 cm on wire grill**		2	180	50 ... 60
	One level	Round black metal dish with a diameter of 20 cm on wire grill**		2	170	50 ... 60
	2 levels	1-Round black metal dish with a diameter of 20 cm on wire grill** 4-Round black metal dish with a diameter of 20 cm on pastry tray**		1 - 4	170	50 ... 60

It is suggested to perform preheating for all foods.
 * These accessories may not be supplied with the product.
 ** These accessories are not supplied with the product. They are commercially available accessories.

Tips for baking cake

- If the cake is too dry, increase the temperature by 10°C and decrease the cooking time.
- If the cake is wet, use less liquid or lower the temperature by 10°C.
- If the cake is too dark on top, place it on a lower rack, lower the temperature and increase the cooking time.
- If cooked well on the inside but sticky on the outside use less liquid, lower the temperature and increase the cooking time.

Tips for baking pastry

- If the pastry is too dry, increase the temperature by 10°C and decrease the cooking time. Dampen the layers of dough with a sauce composed of milk, oil, egg and yoghurt.
- If the pastry takes too long to bake, pay care that the thickness of the pastry you have prepared does not exceed the depth of the tray.
- If the upper side of the pastry gets browned, but the lower part is not cooked, make sure that the amount of sauce you have used for the pastry is not too much at the bottom of the pastry. Try to scatter the sauce equally between the dough layers and on the top of pastry for an even browning.



Cook the pastry in accordance with the mode and temperature given in the cooking table. If the bottom part is still not browned enough, place it on one lower rack next time.

Tips for cooking vegetables

- If the vegetable dish runs out of juice and gets too dry, cook it in a pan with a lid instead of a tray. Closed vessels will preserve the juice of the dish.
- If a vegetable dish does not get cooked, boil the vegetables beforehand or prepare them like canned food and put in the oven.

How to operate the grill



WARNING

Close oven door during grilling.
Hot surfaces may cause burns!

Switching on the grill

1. Turn the Function knob to the desired grill symbol.
2. Then, select the desired grilling temperature.
3. If required, perform a preheating of about 5 minutes.

» Temperature light turns on.

Switching off the grill

1. Turn the Function knob to Off (top) position.



Foods that are not suitable for grilling carry the risk of fire. Only grill food which is suitable for intensive grilling heat.

Do not place the food too far in the back of the grill. This is the hottest area and fatty food may catch fire.

Cooking times table for grilling

Grilling with electric grill

Food	Accessory to use	Rack position	Recommended temperature (°C)**	Cooking time (approx. in min.)
Fish	Wire grill	4..5	250/max	20...25 min.*
Sliced chicken	Wire grill	4..5	250/max	25...35 min.
Lamb chops	Wire grill	4..5	250/max	20...25 min.
Roast beef	Wire grill	4..5	250/max	25...30 min.*
Veal chops	Wire grill	4..5	250/max	25...30 min.*
Toast bread*	Wire grill	4	250/max	1...3 min.

*depending on thickness

*Preheat for 5 minutes

**If the grill temperature of your product cannot be adjusted, the grill will work at the maximum temperature.

Meals in this cooking table are prepared according to EN 60350-1 to make it easier for control institutes to test the product

Food	Accessory to use	Rack position	Temperature (°C)	Cooking time (approx. in min.)
Toast bread	Wire grill	4	250/max	1...3 min.
Meatballs (beef) - 12 pieces	Wire grill	4	250/max	25...35 min.

Turn the food after 2/3 of the total grilling time.

It is suggested to perform 5-6 minutes preheating for all foods broiling.

6 Maintenance and care

General information

Service life of the product will extend and the possibility of problems will decrease if the product is cleaned at regular intervals.



DANGER:

Disconnect the product from mains supply before starting maintenance and cleaning works.

There is the risk of electric shock!



DANGER:

Allow the product to cool down before you clean it.

Hot surfaces may cause burns!

- Clean the product thoroughly after each use. In this way it will be possible to remove cooking residues more easily, thus avoiding these from burning the next time the appliance is used.
- No special cleaning agents are required for cleaning the product. Use warm water with washing liquid, a soft cloth or sponge to clean the product and wipe it with a dry cloth.
- Always ensure any excess liquid is thoroughly wiped off after cleaning and any spillage is immediately wiped dry.
- Do not use cleaning agents that contain acid or chloride to clean the stainless or inox surfaces and the handle. Use a soft cloth with a liquid detergent (not abrasive) to wipe those parts clean, paying attention to sweep in one direction.



The surface might get damaged by some detergents or cleaning materials.

Do not use aggressive detergents, cleaning powders/creams or any sharp objects during cleaning.

Do not use harsh abrasive cleaners or sharp metal scrapers to clean the oven door glass since they can scratch the surface, which may result in shattering of the glass.



Do not use steam cleaners to clean the appliance as this may cause an electric shock.

Cleaning the control panel

Clean the control panel and knobs with a damp cloth and wipe them dry.



If your product is equipped with buttons/knobs do not remove the control buttons/knobs to clean the control panel.

Control panel may get damaged!

Cleaning the oven

To clean the side wall (Varies depending on the product model.)

(This feature is optional. It may not exist on your product.)

1. Remove the front section of the side rack by pulling it in the opposite direction of the side wall.
2. Remove the side rack completely by pulling it towards you.

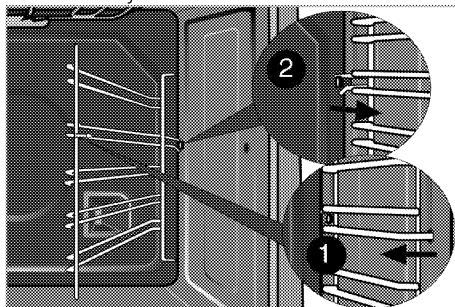

Catalytic walls

(This feature is optional. It may not exist on your product.)

The inner side walls (A) and/or the rear wall (B) of your product may be coated with catalytic enamel. Catalytic walls have a light matte colour and a porous surface. Catalytic walls of the oven should not be cleaned. Porous surfaces of the catalytic walls are automatically cleaned by absorbing and converting the spilled oil (steam and carbon dioxide).

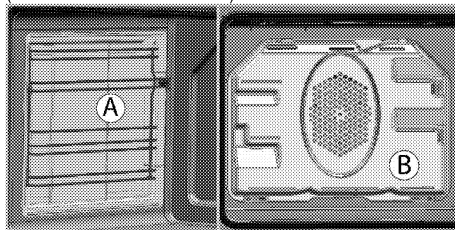

Easy Steam Cleaning

It ensures easy cleaning because the dirt (having waited not for too long) is softened with the steam that forms inside the oven and the water drops condensing on the inner surfaces of the oven.

1. Remove all accessories inside the oven.

- Pour 500 ml of water into the oven tray and place the tray at the 2nd rack of the oven.

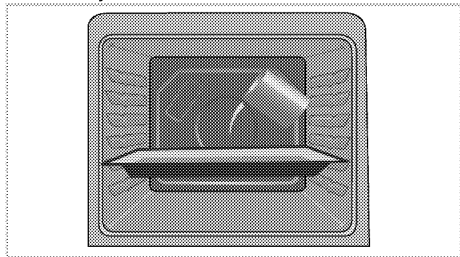

- Set the oven to easy steam cleaning mode and run at 100°C for 25 minutes.
- Open the door and wipe the inner surfaces of the oven with a damp sponge or cloth.
- Use warm water with washing liquid, a soft cloth or sponge to clean the persistent dirt and wipe it with a dry cloth.

i During the easy steam cleaning mode, water that is placed in the tray to soften lightly formed residues/dirt within the oven cavity will evaporate and condense in the oven cavity and inner glass of the oven door, therefore water may drip when the oven door is opened. Wipe away the condensation as soon as the oven door is opened.

Clean oven door

To clean the oven door, use warm water with washing liquid, a soft cloth or sponge to clean the product and wipe it with a dry cloth.

i Don't use any harsh abrasive cleaners or sharp metal scrapers for cleaning the oven door. They could scratch the surface and destroy the glass.

Removing the oven door

- Open the front door (1).
- Open the clips at the hinge housing (2) on the right and left hand sides of the front door by pressing them down as illustrated in the figure.

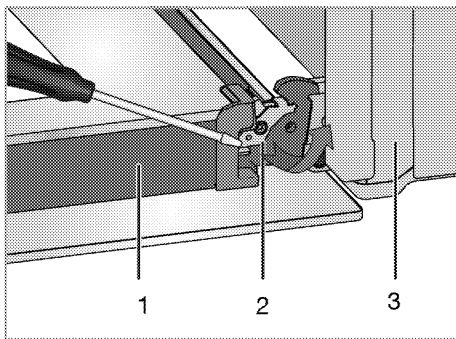

- Door
- Hinge lock(closed position)
- Oven
- Hinge lock(open position)

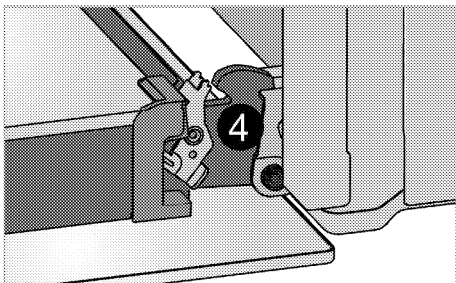

- Move the front door to half-way.

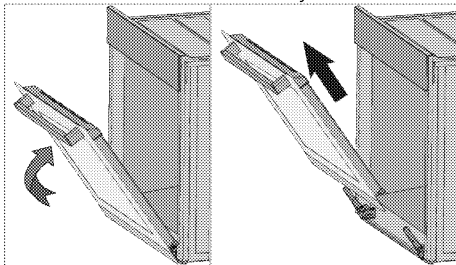

- Remove the front door by pulling it upwards to release it from the right and left hinges.

i Steps carried out during removing process should be performed in reverse order to install the door. Do not forget to close the clips at the hinge housing when reinstalling the door.

Removing the door inner glass

(This feature is optional. It may not exist on your product.)

The inner glass panel of the oven door can be removed for cleaning.
Open the oven door.

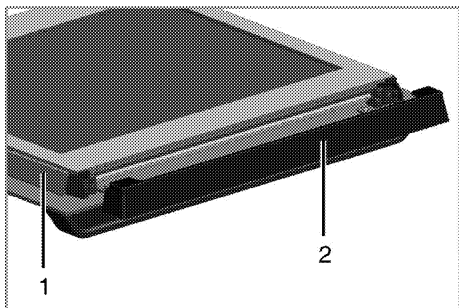

- 1 Frame
- 2 Plastic part

Pull towards yourself and remove the plastic part installed to upper section of the front door.

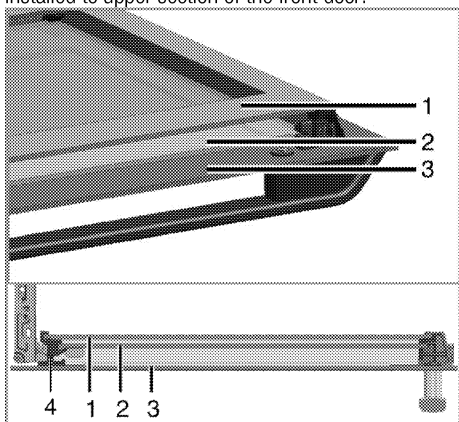

- 1 Innermost glass panel
- 2 Inner glass panel
- 3 Outer glass panel
- 4 Plastic glass panel slot-Lower

As illustrated in figure, raise the innermost glass panel (1) slightly in direction **A** and pull it out in direction **B**. Repeat the same procedure to remove the inner glass panel (2).

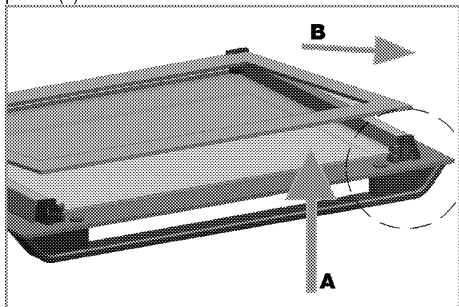

The first step to regroup the door is reinstalling inner glass panel (2).

As illustrated in figure, place the chamfered corner of the glass panel so that it will rest in the chamfered corner of the plastic slot.

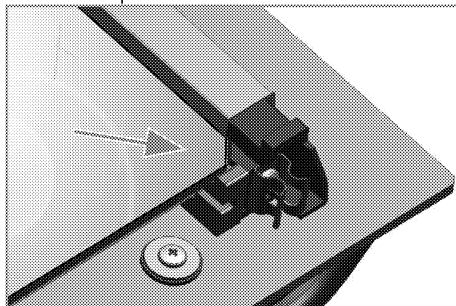

Inner glass panel (2) must be installed into the plastic slot close the innermost glass panel (1).

When installing the innermost glass panel (1), make sure that the printed side of the panel faces towards the inner glass panel.

It is important to seat lower corner of inner glass panel into the lower plastic slot.

Push the plastic part towards the frame until you hear a "click".

Replacing the oven lamp



DANGER:

Before replacing the oven lamp, make sure that the product is disconnected from mains and cooled down in order to avoid the risk of an electrical shock. Hot surfaces may cause burns!



The oven lamp is a special electric light bulb that can resist up to 300 °C. See *Technical specifications, page 11* for details. Oven lamps can be obtained from Authorised Service Agents or technician with licence.



Position of lamp might vary from the figure.



The lamp used in this appliance is not suitable for household room illumination. The intended purpose of this lamp is to assist the user to see foodstuffs.



The lamps used in this appliance have to withstand extreme physical conditions such as temperatures above 50 °C.

If your oven is equipped with a round lamp:

1. Disconnect the product from mains.

2. Turn the glass cover counter clockwise to remove it.

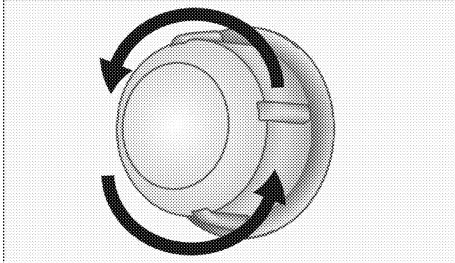

3. If your oven lamp is of type (A) shown in the figure below, remove it by rotating as shown and replace it. If it is of type (B), pull and remove it as shown in the figure and replace it.

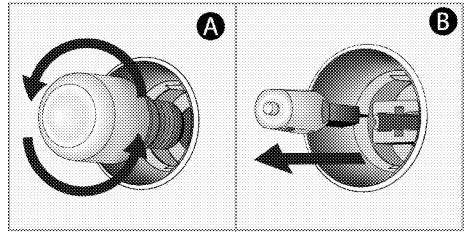

4. Install the glass cover.

7 Troubleshooting

Oven emits steam when it is in use.

- It is normal that steam escapes during operation. >>> *This is not a fault.*

Product emits metal noises while heating and cooling.

- When the metal parts are heated, they may expand and cause noise. >>> *This is not a fault.*

Product does not operate.

- The mains fuse is defective or has tripped. >>> *Check fuses in the fuse box. If necessary, replace or reset them.*
- Product is not plugged into the (grounded) socket. >>> *Check the plug connection.*

Oven light does not work.

- Oven lamp is defective. >>> *Replace oven lamp.*
- Power is cut. >>> *Check if there is power. Check the fuses in the fuse box. If necessary, replace or reset the fuses.*

Oven does not heat.

- Might not be set to a certain cooking function and/or temperature. >>> *Set the oven to a certain cooking function and/or temperature.*
- In models equipped with a timer, the timer is not adjusted. >>> *Adjust the time.*
(In products with microwave oven, timer controls only microwave oven.)
- Power is cut. >>> *Check if there is power. Check the fuses in the fuse box. If necessary, replace or reset the fuses.*

(In models with timer) Clock display is blinking or clock symbol is on.

- A previous power outage has occurred. >>> *Adjust the time / Switch of the product and switch it on again.*



Consult the Authorised Service Agent or technician with licence or the dealer where you have purchased the product if you can not remedy the trouble although you have implemented the instructions in this section. Never attempt to repair a defective product yourself.

Einbau-Backofen

Gebrauchsanleitung

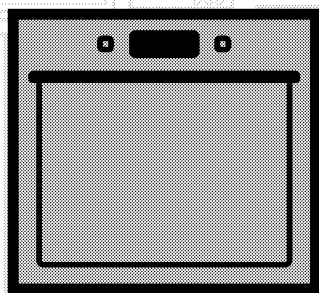

DE

beko

Bitte zuerst diese Bedienungsanleitung lesen!

Sehr geehrte Kundin, sehr geehrter Kunde,
vielen Dank für den Kauf eines Beko-Produktes. Wir hoffen, dass dieses Produkt, das mit hochwertiger und hochmoderner Technologie hergestellt wurde, beste Ergebnisse erzielt. Daher bitte die gesamte Bedienungsanleitung und alle beiliegenden Dokumente aufmerksam durchlesen und zum zukünftigen Nachschlagen aufbewahren. Bei Weitergabe des Produktes auch die Bedienungsanleitung mit aushändigen. Alle Warnungen und Informationen in der Bedienungsanleitung einhalten.

Bitte beachten, dass diese Bedienungsanleitung für unterschiedliche Modelle geschrieben wurde. Unterschiede zwischen den verschiedenen Modellen werden natürlich in der Anleitung erwähnt.

Die Symbole

In dieser Anleitung verwenden wir folgende Symbole:



Wichtige Informationen oder nützliche
Tipps zum Gebrauch.



Warnung vor gefährlichen Situationen,
in denen es zu Verletzungen oder
Sachschäden kommen kann.



Warnung vor Stromschlägen.



Warnung vor Brandgefahr.



Warnung vor heißen Flächen.



Arçelik A.Ş.
Karaağaç caddesi No:2-6
34445 Sütlüce/Istanbul/TURKEY
Made in TURKEY

1 Wichtige Sicherheits- und Umwelthinweise **4**

Allgemeine Sicherheit.....	4
Elektrische Sicherheit.....	5
Produktsicherheit.....	6
Bestimmungsgemäße Verwendung.....	8
Sicherheit von Kindern.....	8
Altgeräte entsorgen.....	8
Verpackungsmaterialien entsorgen.....	9
Transport.....	9

2 Allgemeine Informationen **10**

Geräteübersicht.....	10
Lieferumfang.....	11
Technische Daten.....	12

3 Installation **13**

Vor der Installation.....	13
Einbauen und Anschließen.....	15

4 Vorbereitungen **17**

Tipps zum Energiesparen.....	17
Erste Inbetriebnahme.....	17
Zeiteinstellung.....	17
Erstreinigung des Gerätes.....	17
Erstaufheizung.....	17

5 Bedienung des Backofens **19**

Allgemeine Hinweise zum Backen, Braten und Grillen.....	19
So bedienen Sie den Backofen.....	19
Betriebsarten.....	20
Ofenuhr verwenden.....	21
Garzeitentabelle.....	23
So bedienen Sie den Grill.....	26
Garzeitentabelle zum Grillen.....	26

6 Reinigung und Wartung **27**

Allgemeine Hinweise.....	27
Bedienfeld reinigen.....	27
Backofen reinigen.....	27
Backofentür ausbauen.....	28
Türinnenscheibe ausbauen.....	28
Beleuchtung des Backofens austauschen.....	29

7 Problemlösungen **31**

1 Wichtige Sicherheits- und Umwelthinweise

Dieser Abschnitt enthält Hinweise, die für die Sicherheit des Benutzers und anderer Personen unerlässlich sind. Diese Hinweise müssen beachtet werden, damit es nicht zu Verletzungen oder Sachschäden kommt.

Bei Nichteinhaltung dieser Anweisungen erlöschen sämtliche Garantieansprüche.

Allgemeine Sicherheit

- Dieses Gerät darf von Kindern (ab acht Jahren) oder Personen bedient werden, die unter körperlichen, sensorischen oder geistigen Einschränkungen leiden oder denen es an der nötigen Erfahrung und Wissen im Umgang mit solchen Geräten mangelt, wenn solche Personen beaufsichtigt werden und, zuvor gründlich mit der sicheren Bedienung des Gerätes vertraut gemacht wurden und sich der damit verbundenen Gefahren voll und ganz bewusst sind. Kinder dürfen nicht mit dem Gerät spielen. Reinigungs- und Wartungsarbeiten dürfen von Kindern nicht ohne Aufsicht eines Erwachsenen durchgeführt werden.
- Das Gerät darf nicht von Personen genutzt werden, die unter körperlichen oder geistigen Einschränkungen leiden oder denen es an der nötigen Erfahrung im Umgang mit solchen Geräten mangelt. Ausnahmen sind nur dann möglich, wenn solche Personen beaufsichtigt werden oder gründlich über den richtigen Umgang mit dem Gerät aufgeklärt wurden. Dies gilt natürlich auch für Kinder. Kinder müssen stets beaufsichtigt werden, damit sie nicht mit dem Gerät spielen.
- Falls das Produkt an jemand anderen zur persönlichen oder Secondhand-Benutzung übergeben wird, sollten Bedienungsanleitung, Produktetiketten und andere relevante Dokumente und Teile ebenfalls übergeben werden.
- Installation und Reparaturen müssen grundsätzlich vom autorisierten Kundendienst ausgeführt werden. Der Hersteller haftet nicht für Schäden, die durch den Eingriff nicht autorisierter Personen entstehen; zudem kann dadurch die Garantie erlöschen. Vor der Installation aufmerksam alle Anweisungen lesen.
- Gerät nicht nutzen, falls es nicht ordnungsgemäß funktioniert oder

sichtbare Beschädigungen aufweist.

- Nach jeder Benutzung prüfen, ob die Funktionsknöpfe des Produktes ausgeschaltet sind.

Elektrische Sicherheit

- Falls das Produkt einen Fehler aufweist, sollte es bis zur Reparatur durch einen autorisierten Kundendienstmitarbeiter nicht in Betrieb genommen werden. Es besteht Stromschlaggefahr!
- Schließen Sie das Produkt nur an eine geerdete Steckdose an, deren Spannung und Schutz den Angaben unter „Technische Daten“ entsprechen. Lassen Sie durch einen qualifizierten Elektriker eine Erdung vornehmen. Unser Unternehmen haftet nicht für Probleme, die durch ein nicht entsprechend den örtlichen Richtlinien geerdetes Produkt entstehen.
- Reinigen Sie das Produkt niemals, indem Sie Wasser darauf verteilen oder schütten! Es besteht Stromschlaggefahr!
- Berühren Sie den Stecker niemals mit feuchten oder gar nassen Händen! Trennen Sie das Kabel niemals durch Ziehen am Kabel; greifen und ziehen Sie immer am Stecker.
- Das Produkt darf während Installation, Wartung, Reinigung und Reparatur nicht an eine Steckdose angeschlossen sein.
- Falls das Netzkabel des Produktes beschädigt ist, muss es zur Vermeidung von Gefahren vom Hersteller, einem Kundendienstmitarbeiter oder vergleichbar qualifizierten Personen ausgetauscht werden.
- Das Gerät muss so installiert sein, dass es vollständig vom Netzwerk getrennt werden kann. Die Trennung muss entsprechend den Baurichtlinien entweder durch einen Netzstecker oder einen in der festen elektrischen Installation eingebauten Schalter ermöglicht werden.
- Die Rückseite des Ofens wird im Betrieb heiß. Achten Sie darauf, dass der Elektroanschluss die Rückseite nicht berührt; andernfalls kann der Anschluss beschädigt werden.
- Klemmen Sie das Netzkabel nicht zwischen Backofentür und Rahmen ein; führen Sie es nicht über heiße Oberflächen. Andernfalls kann die Kabelisolierung schmelzen und in Folge eines Kurzschlusses einen Brand verursachen.
- Jegliche Arbeiten an elektrischen Geräten und Systemen sollten von

autorisierten und qualifizierten Personen ausgeführt werden.

- Schalten Sie das Gerät bei Schäden aus, unterbrechen Sie die entsprechende Stromversorgung. Schalten Sie dazu die Sicherungen im Haus ab.
- Stellen Sie sicher, dass die Sicherungsangaben mit dem Produkt kompatibel sind.

Produktsicherheit

- **WARNUNG:** Das Gerät und seine zugänglichen Teile werden während des Betriebs heiß. Keine Heizelemente berühren. Kinder unter 8 Jahren fernhalten, sofern nicht kontinuierlich beaufsichtigt.
- Produkt niemals nutzen, wenn Urteilsvermögen oder Koordination durch Alkohol und/oder Drogen beeinträchtigt sind.
- Bei alkoholischen Getränken in den Gerichten entsprechend vorsichtig sein. Alkohol verdampft bei hohen Temperaturen und kann durch Entzünden bei Kontakt mit heißen Oberflächen Feuer verursachen.
- Keine brennbaren Materialien in der Nähe des Produktes aufstellen, da die Seiten während des Gebrauchs heiß werden können.
- Während des Gebrauchs wird das Gerät heiß. Keine Heizelemente

im Inneren des Backofens berühren.

- Darauf achten, dass keine Belüftungsschlitze blockiert werden.
- Keine geschlossenen Dosen und Glasgefäße im Ofen erhitzen. Der in der Dose/im Glasgefäß entstehende Druck könnte Dose/Glasgefäß bersten lassen.
- Backbleche, Gerichte und Alufolie nicht direkt auf den Boden des Backofens stellen. Der Hitzestau kann den Boden des Backofens beschädigen.
- Zur Reinigung der Backofen-Glastür keine aggressiven scheuernden Reiniger oder scharfen Metallschaber verwenden, da diese die Oberfläche zerkratzen und so das Glas springen lassen können.
- Zur Reinigung des Gerätes keine Dampfreiniger verwenden; andernfalls besteht Stromschlaggefahr.
- (Variiert je nach Produktmodell.) Rost und Backblech richtig einsetzen
Es ist wichtig, dass Rost und/oder Blech richtig in den Einschüben sitzen. Schieben Sie Rost oder Blech zwischen zwei Schienen ein, vergewissern Sie sich, dass insbesondere der Rost gerade sitzt, bevor Sie Lebensmittel

darauf legen; bitte schauen Sie sich die folgende Abbildung an.

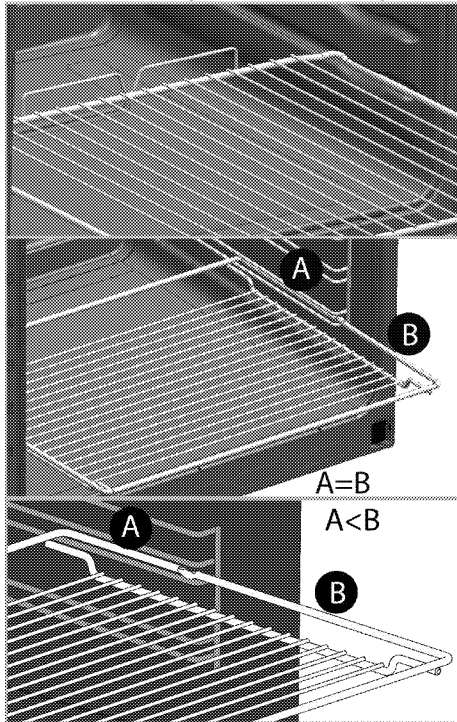

- Produkt nicht verwenden, falls das Glas der Fronttür entfernt oder gesprungen ist.
- Griff der Ofentüre nicht zum Trocknen von Geschirrtüchern verwenden. Keine Geschirrtücher, Handschuhe oder vergleichbare Textilprodukte aufhängen, wenn die Grillfunktion bei geöffneter Tür arbeitet.
- Beim Hineingeben oder Herausnehmen von Gerichten in den/aus dem heißen Ofen immer hitzebeständige Handschuhe verwenden.

- Legen Sie das Backpapier mit den Lebensmitteln in einem Kochtopf oder auf einem Ofenzubehör (Backblech, Rost etc.) aus und geben Sie alles zusammen in den vorgeheizten Ofen. Entfernen Sie überschüssige Bereiche des Backpapiers, die über das Zubehör oder den Topf hinausragen, damit es keine Heizelemente des Ofens berührt. Verwenden Sie Backpapier niemals bei einer Betriebstemperatur, welche die für das Backpapier angegebenen Werte übersteigen. Legen Sie Backpapier nicht direkt auf dem Boden des Ofens aus.
 - **WARNUNG:** Stellen Sie vor dem Lampenwechsel sicher, dass das Netzkabel des Gerätes getrennt oder die Sicherung deaktiviert ist, damit kein Stromschlag möglich ist.
 - Damit es nicht zu Überhitzung kommt, darf das Gerät nicht hinter Zierklappen/Ziertüren aufgestellt werden
- Brandschutzvorkehrungen des Produktes:
- Sicherstellen, dass die elektrische Verbindung richtig in die Steckdose eingesteckt ist und keine Funken erzeugt.
 - Keine beschädigten oder abgeschnittenen Kabel bzw.

Verlängerungskabel verwenden;
nur das Originalkabel einsetzen.

- Beim Anschließen des Produktes sicherstellen, dass sich keine Flüssigkeit oder Feuchtigkeit an der elektrischen Verbindung befindet.

Bestimmungsgemäße Verwendung

- Dieses Gerät wurde für den reinen Hausgebrauch entwickelt. Eine gewerbliche Nutzung ist nicht zulässig.
- **VORSICHT:** Dieses Gerät dient ausschließlich der Zubereitung von Speisen. Es darf nicht zu anderen Zwecken eingesetzt werden.
- Benutzen Sie das Gerät nicht zum Vorwärmen von Tellern, hängen Sie keine Küchentücher, Handtücher und dergleichen zum Trocknen oder Anwärmen an die Griffe.
- Der Hersteller haftet nicht für Schäden, die durch unsachgemäßen Gebrauch oder falsche Bedienung verursacht werden.
- Das Gerät ist zum Garen, Auftauen, Backen, Braten und Grillen von Lebensmitteln geeignet.

Sicherheit von Kindern

- **WARNUNG:** Verschiedene Teile des Gerätes werden während des

Gebrauchs heiß. Daher kleine Kinder vom Gerät fernhalten.

- Verpackungsmaterialien können eine Gefahr für Kinder darstellen. Sämtliche Verpackungsmaterialien an einem sicheren Ort und außerhalb der Reichweite von Kindern aufbewahren.
- Elektrische Produkte können eine Gefahr für Kinder darstellen. Kinder im Betrieb daher unbedingt vom Gerät fernhalten. Kinder nicht mit dem Gerät spielen lassen.
- Keine Gegenstände auf das Gerät stellen, die Kinder erreichen können.
- Wenn die Ofentür geöffnet ist, keine schweren Gegenstände darauf ablegen und keine Kinder darauf sitzen lassen. Das Gerät kann kippen oder die Ofentür oder die Türscharniere können beschädigt werden.

Altgeräte entsorgen

Erfüllung von WEEE-Vorgaben zur Entsorgung von Altgeräten:



Dieses Produkt erfüllt die Vorgaben der EU-WEEE-Direktive (2012/19/EU). Das Produkt wurde mit einem Klassifizierungssymbol für elektrische und elektronische Altgeräte (WEEE) gekennzeichnet. Dieses Gerät wurde aus hochwertigen Materialien hergestellt, die wiederverwendet und recycelt werden können. Entsorgen Sie das Gerät am Ende seiner Einsatzzeit nicht mit dem regulären Hausmüll; geben Sie es stattdessen bei einer Sammelstelle zur Wiederverwertung von elektrischen und elektronischen

Altgeräten ab. Ihre Stadtverwaltung informiert Sie gerne über geeignete Sammelstellen in Ihrer Nähe.

Einhaltung von RoHS-Vorgaben:

Das von Ihnen erworbene Produkt erfüllt die Vorgaben der EU-RoHS Richtlinie (2011/65/EU). Es enthält keine in der Richtlinie angegebenen gefährlichen und unzulässigen Materialien.



Verpackungsmaterialien entsorgen

- Die Verpackung des Gerätes besteht aus wiederverwertbaren Materialien. Entsorgen Sie diese vorschriftsgemäß und entsprechend sortiert. Entsorgen Sie solche Materialien nicht mit dem normalen Hausmüll.

Transport

- Bewahren Sie den Originalkarton auf, falls Sie das Gerät künftig transportieren müssen. Halten Sie sich an die Hinweise auf dem Karton. Falls Sie den Originalkarton nicht mehr besitzen sollten, verpacken Sie das Gerät in Luftpolsterfolie oder starken Karton, anschließend gut mit Klebeband sichern.

- Damit Gitterroste und Bleche nicht zu Beschädigungen der Ofentür führen, schützen Sie die Ofentür von innen mit einem passenden Stück Karton. Fixieren Sie die Ofentür mit Klebeband.
- Verwenden Sie die Tür/den Türgriff nicht zum Anheben oder Bewegen des Gerätes.

	Legen Sie keine Gegenstände auf dem Gerät ab, bewegen Sie das Gerät grundsätzlich in aufrechter Position.
	Überprüfen Sie das Gerät nach dem Transport genau, überzeugen Sie sich davon, dass es nicht zu Beschädigungen gekommen ist.

2 Allgemeine Informationen

Geräteübersicht

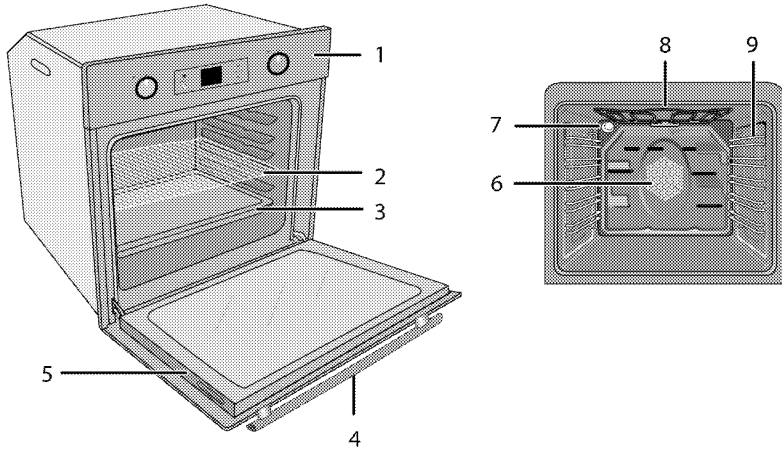

- | | | | |
|---|------------|---|---------------------------------------|
| 1 | Bedienfeld | 6 | Lüftermotor (hinter der Metallplatte) |
| 2 | Gitterrost | 7 | Beleuchtung |
| 3 | Backblech | 8 | Oberes Heizelement |
| 4 | Griff | 9 | Einschubpositionen |
| 5 | Tür | | |

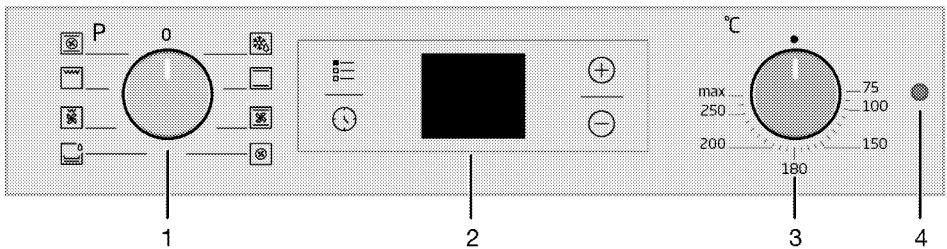

- | | |
|---|-------------------|
| 1 | Funktionsknopf |
| 2 | Digitaltimer |
| 3 | Temperaturknopf |
| 4 | Temperaturleuchte |

Lieferumfang



Je nach Modell wird eventuell unterschiedliches Zubehör mitgeliefert. Daher kann es vorkommen, dass nicht sämtliches in der Anleitung erwähntes Zubehör mit Ihrem Gerät geliefert wird.

1. Bedienungsanleitung

2. Backblech

Für Backwaren, Tiefkühlgerichte und große Braten.

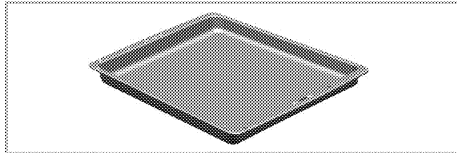

3. Gebäckblech

Für Gebäck wie Kekse, Biskuits und Kuchen.

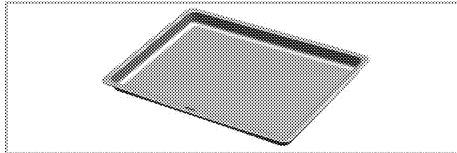

4. Rost

Zum Rösten und Grillen und als Unterlage für Behälter, in denen unterschiedlichste Lebensmittel gegart werden können.

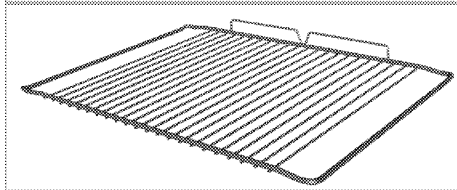
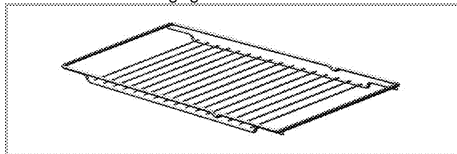

5. Gitterrost und Backblech richtig in die Teleskopeinschübe einschieben (Dieses Merkmal ist optional. Es ist bei Ihrem Modell möglicherweise nicht vorhanden.)

Durch die Teleskopeinschübe lassen sich Bleche und Rost besonders leicht einlegen und entfernen.

Achten Sie beim Einsatz von Backblech und Gitterrost mit den Teleskopeinschüben darauf, dass die Stifte am rückwärtigen Teil des Teleskopeinschubs die Kanten von Backblech und Gitterrost berühren.

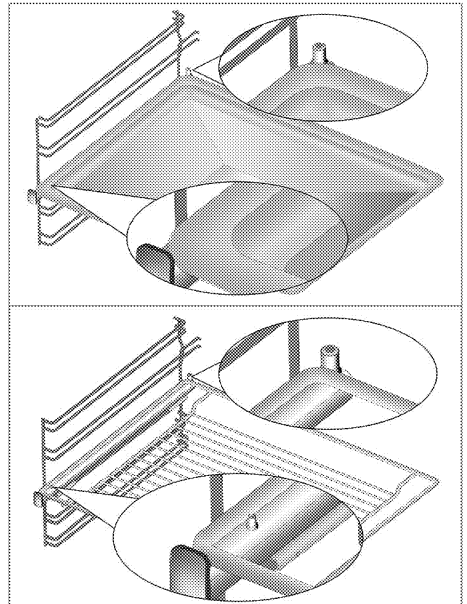

Technische Daten

Spannung/Frequenz	220-240 V ~ 50 Hz
Leistungsaufnahme gesamt	2,5 kW
Kabeltyp/Kabelquerschnitt	MinimumH05VV-FG 3 x 1,5 mm ²
Außenabmessungen (Höhe/Breite/Tiefe)	595 mm/594 mm/567 mm
Einbaumaße (Höhe/Breite/Tiefe)	**590 oder 600 mm/560 mm/Minimum 550 mm
Hauptofen	Multifunktionsofen
Garraumleuchte	15/25 W
Leistungsaufnahme Grill	2,2 kW

Allgemeine Hinweise: Energieangaben von Elektroöfen werden gemäß des Standards EN 60350-1 / IEC 60350-1 ermittelt. Die entsprechenden Werte werden unter üblichen Einsatzbedingungen bei Ober-/Unterhitze oder im Umluftbetrieb (sofern vorhanden) ermittelt.

Die Energieeffizienzklasse wird gemäß Funktion ermittelt: je nachdem, ob das Gerät mit den entsprechenden Funktionen ausgestattet ist. 1. Garen mit Eco-Umluft, 2. Turbo-Niedertemperaturgaren, 3. Turbogaren, 4. Ober-/Unterhitze mit Umluft, 5. Ober-/Unterhitze



Im Zuge der Qualitätsverbesserung können sich technische Daten ohne Vorankündigung ändern.



Die Abbildungen in dieser Anleitung dienen lediglich der Veranschaulichung und können etwas vom tatsächlichen Aussehen des Gerätes abweichen.



Angaben am Produkt oder in der begleitenden Dokumentation wurden unter Laborbedingungen unter Berücksichtigung der zutreffenden Richtlinien ermittelt. Solche Werte können je nach Einsatzumgebung und Nutzungsweise des Gerätes abweichen.

3 Installation

Gerät vom nächstgelegenen autorisierten Kundendienst gemäß gültigen Bestimmungen installieren lassen. Andernfalls erlischt die Garantie. Der Hersteller haftet nicht für Schäden, die durch Aktivitäten nicht autorisierter Personen entstehen; zudem kann dadurch die Garantie erlöschen.



Die Vorbereitung des Aufstellungsortes und der elektrischen Anschlüsse sind Sache des Kunden.



GEFAHR:

Die Installation des Gerätes muss in Übereinstimmung mit sämtlichen zutreffenden Vorschriften zur Elektroinstallation erfolgen.



GEFAHR:

Gerät vor der Installation auf eventuelle, sichtbare Defekte untersuchen. Falls Defekte vorliegen, darf das Gerät nicht installiert werden.

Beschädigte Geräte müssen grundsätzlich als Sicherheitsrisiko betrachtet werden.

Vor der Installation

Das Gerät ist für den Einbau in handelsübliche Küchenmöbel vorgesehen. Zwischen Gerät und angrenzenden Küchenwänden und -möbeln muss ein Sicherheitsabstand verbleiben. Siehe Abbildung auf der nächsten Seite (Angaben in mm).

- Oberflächen, Kunststoffbeläge und verwendete Kleber müssen hitzebeständig sein (bis mindestens 100 °C).
- Küchenmöbel müssen waagrecht ausgerichtet und fixiert sein.
- Befindet sich unter dem Backofen eine Schublade, muss zwischen Backofen und Schublade ein Trennboden eingesetzt werden.
- Tragen Sie das Gerät grundsätzlich mit mindestens zwei Personen.
- Halten Sie den Ofen zum Transportieren an den Schlitten an beiden Seiten.
- Entfernen Sie vor Installation des Produktes alle darin befindlichen Materialien und Dokumente.
- Das Küchenmöbel muss mit den in der nachstehenden Abbildung angegebenen Abmessungen übereinstimmen. Im hinteren Bereich des Küchenmöbels muss zur Gewährleistung einer ausreichenden Belüftung eine Öffnung mit den in der nachstehenden Abbildung angegebenen Abmessungen ausgeschnitten werden.



Stellen Sie das Gerät nicht neben Kühl- oder Gefriergeräten auf. Die Wärmeabgabe des Gerätes führt zu steigendem Energieverbrauch der Kühlgeräte.



Missbrauchen Sie die Tür/den Türgriff nicht zum Anheben oder Bewegen des Gerätes.

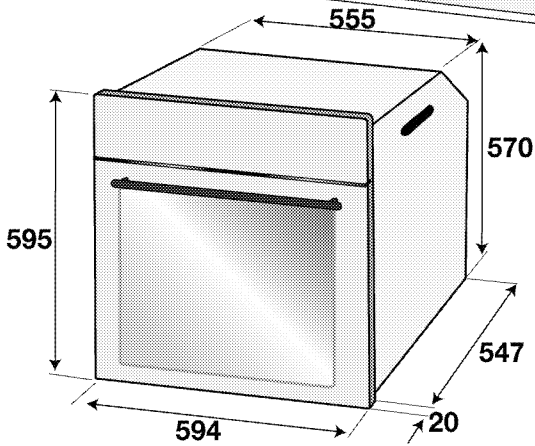
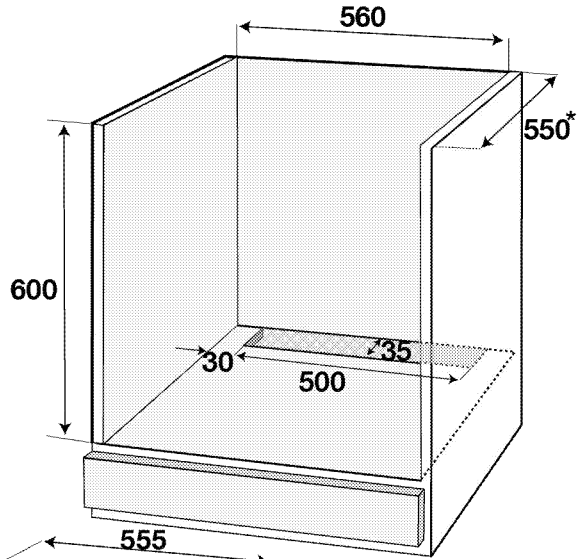
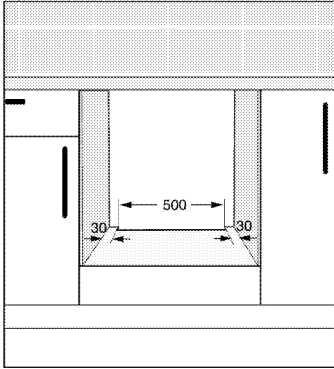
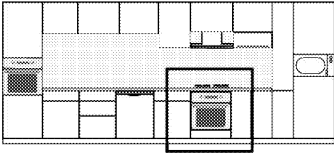

* Minimum

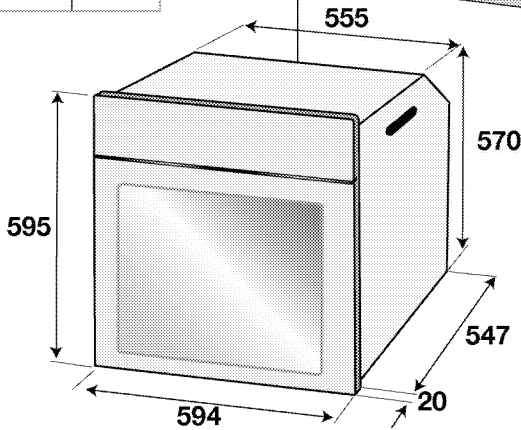
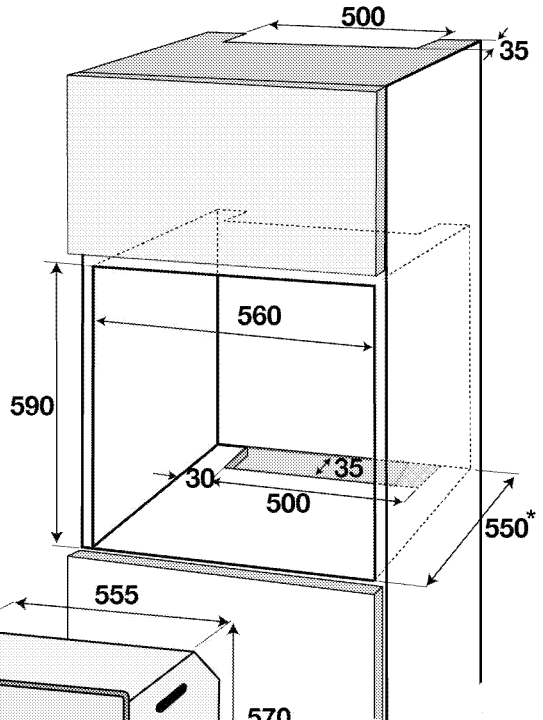
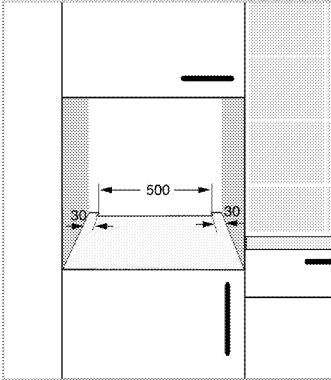
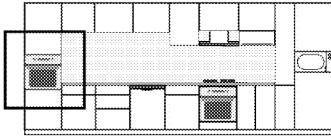

* Minimum

Einbauen und Anschließen

- Die Installation des Gerätes muss in Übereinstimmung mit sämtlichen zutreffenden Vorschriften zur Gas- und Elektroinstallation erfolgen.

Elektrischer Anschluss

Schließen Sie das Gerät an eine geerdete Schutzkontaktsteckdose/Leitung an, die mit einem Miniatur-Leistungtrennschalter passender Kapazität gemäß der „Technische Daten“-Tabelle abgesichert wird. Lassen Sie durch einen qualifizierten Elektriker eine Erdung vornehmen, egal ob Sie das Produkt mit

oder ohne Transformator verwenden. Der Hersteller haftet nicht bei Schäden, die durch den Einsatz des Gerätes ohne vorschriftsmäßige Erdung entstehen.



GEFAHR:

Das Gerät darf nur von einer autorisierten Fachkraft an das Stromnetz angeschlossen werden.

Der Hersteller haftet nicht für Schäden, die durch Aktivitäten nicht autorisierter Dritter entstehen.

**GEFAHR:**

Das Netzkabel darf nicht eingeklemmt, geknickt oder gequetscht werden und darf nicht mit heißen Geräteteilen in Berührung kommen.
Beschädigte Netzkabel müssen durch einen zugelassenen Elektriker ausgetauscht werden. Andernfalls kann es zu Stromschlägen, Kurzschlüssen und Bränden kommen!

- Der Anschluss muss gemäß nationalen Richtlinien erfolgen.
- Die Netzanschlussdaten müssen mit den Daten auf dem Typenschild des Gerätes übereinstimmen. Das Typenschild finden Sie nach Öffnen der Ofentür an der Unterseite des Gerätes.
- Verwenden Sie nur Netzkabel, die den Angaben im Abschnitt „Technische Daten“ entsprechen.

**GEFAHR:**

Trennen Sie das Gerät vollständig von der Stromversorgung, bevor Sie mit der Elektroinstallation beginnen.
Es besteht Stromschlaggefahr!



Der Netzstecker muss nach der Installation frei zugänglich bleiben, das Netzkabel darf jedoch nicht über das Gerät hinweg verlegt werden.



Beim Ausführen der Elektroinstallation müssen die nationalen/lokalen Elektroinstallationsregeln eingehalten und muss eine korrekte Steckdose und ein passender Stecker für den Ofen verwendet werden. Falls die Anschlusswerte des Gerätes zu hoch für den Steckeranschluss sind, muss es ohne Steckverbindung mit direktem Kabelanschluss fest installiert werden.

Stecken Sie den Netzstecker in die Steckdose.

Gerät installieren

1. Schieben Sie den Backofen in die vorgesehene Nische/Küchenschrank, richten Sie ihn richtig aus und fixieren Sie ihn – achten Sie dabei unbedingt darauf, dass das Netzkabel nicht beschädigt oder eingeklemmt wird.

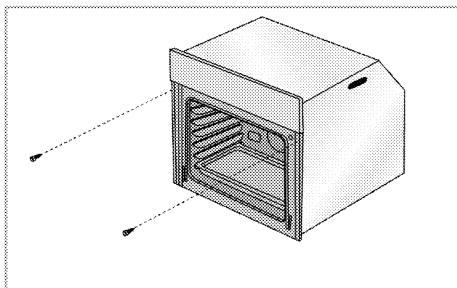

Fixieren Sie den Backofen wie in der Abbildung gezeigt mit zwei Schrauben.

Stellen Sie nach der Installation sicher, dass die Schrauben ausreichend angezogen sind und der Ofen nicht bewegt werden kann. Der Ofen könnte während der Benutzung umkippen, falls er nicht entsprechend den Anweisungen installiert wurde bzw. die Schrauben nicht ausreichend festgezogen wurden.

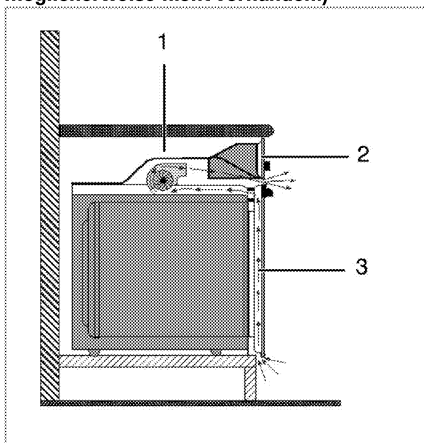
Bei Geräten mit Lüfter (Es ist bei Ihrem Modell möglicherweise nicht vorhanden.)

- 1 Lüfter
- 2 Bedienfeld
- 3 Tür

Der integrierte Lüfter kühlt den Einbauschrank und die Vorderseite des Gerätes.



Der Kühlungs Lüfter läuft auch nach dem Abschalten des Backofens noch etwa 20 bis 30 Minuten lang nach.

Wenn Sie Lebensmittel Timer-programmiert zubereiten, schaltet sich gemeinsam mit den restlichen Funktionen auch der Lüfter zum Ende der Garzeit ab.

Endkontrolle

1. Betrieb des Geräts.
2. Prüfen Sie die Funktion.

4 Vorbereitungen

Tipps zum Energiesparen

Mit den folgenden Hinweisen nutzen Sie Ihr Gerät umweltbewusst und energiesparend:

- Verwenden Sie am besten dunkles oder emailliertes Kochgeschirr – dies leitet die Wärme besser.
- Lassen Sie den Backofen vorheizen, wenn dies durch Bedienungs- oder Zubereitungsanleitung empfohlen wird.
- Verzichten Sie bei der Zubereitung auf häufiges Öffnen der Backofentür.
- Bereiten Sie mehrere Gerichte gleichzeitig zu, sofern dies möglich ist. Dazu stellen Sie einfach mehrere Behälter auf den Gitterrost.
- Größere Gerichte und solche, deren Geschmack sich nicht gegenseitig beeinflussen soll, bereiten Sie nacheinander zu. Der Backofen ist dann bereits vorgeheizt.
- Sie können zusätzliche Energie sparen, indem Sie den Backofen ein paar Minuten vor Ende der Garzeit bereits abschalten. Verzichten Sie während der Zubereitung möglichst auf ein Öffnen der Backofentür.
- Tauen Sie gefrorene Gerichte vor der Zubereitung auf.

Erste Inbetriebnahme

Zeiteinstellung



Wenn Sie Einstellungen ändern, blinken die entsprechenden Symbole in der Anzeige.

Drücken Sie nach dem ersten Einschalten des Ofens zum Einstellen der Uhrzeit \oplus/\ominus .



Berühren Sie bei berührungsgesteuerten Modellen zuerst \equiv und verwenden Sie dann zur Einstellung der Tageszeit \oplus/\ominus .

Bestätigen Sie die Einstellung, indem Sie das Symbol \odot berühren oder 4 Sekunden warten, ohne eine Taste zu berühren.

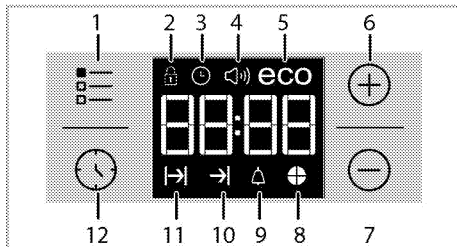

1 Einstelltaste

- 2 Tastensperre-Symbol
- 3 Uhrensymbol
- 4 Alarmlautstärkesymbol (Es ist bei Ihrem Modell möglicherweise nicht vorhanden.)
- 5 Energiesparmodusymbol
- 6 Plus-Taste
- 7 Minus-Taste
- 8 Zeit-Kuchendiagramm
- 9 Alarmsymbol
- 10 Garzeitensymbol
- 11 Garzeitsymbol
- 12 Programmtaste



Wurde die Zeit noch nicht eingestellt, startet die Uhr bei **12:00** und das \odot -Symbol wird angezeigt. Das Symbol verschwindet nach der Zeiteinstellung.



Bei einem Stromausfall werden die aktuellen Zeiteinstellungen abgebrochen. Eine Neueinstellung ist erforderlich.

Erstreinigung des Gerätes



Durch bestimmte Reinigungsmittel können die Oberflächen des Gerätes beschädigt werden. Verwenden Sie keine aggressiven Reinigungsmittel, keine Scheuermittel und keine scharfen oder spitzen Gegenstände bei der Reinigung.

1. Entfernen Sie sämtliches Verpackungsmaterial.
2. Geräteoberflächen mit einem feuchten Tuch oder Schwamm abwischen und mit einem Tuch trocknen.

Erstaufheizung

Lassen Sie das Gerät etwa 30 Minuten lang aufheizen, schalten Sie es anschließend ab. Auf diese Weise werden sämtliche Rückstände und Beschichtungen durch Abbrennen entfernt.



WARNUNG

Verbrennungsgefahr durch heiße Flächen!

Das Gerät kann sich im Betrieb stark aufheizen. Berühren Sie niemals heiße Brenner, das Innere des Backofens, Heizelemente und so weiter. Halten Sie Kinder fern.

Tragen Sie grundsätzlich hitzebeständige Schutzhandschuhe, wenn Sie etwas in den Backofen stellen oder herausnehmen.

Elektroofen

1. Nehmen Sie sämtliches Zubehör (z. B. Backbleche und Gitterrost) aus dem Backofen heraus.

2. Schließen Sie die Backofentür.
3. Wählen Sie die Einstellung „Ober- und Unterhitze“.
4. Wählen Sie die höchste Ofentemperatur; Siehe "*So bedienen Sie den Backofen, Seite 19*".
5. Lassen Sie den Backofen etwa 30 Minuten lang arbeiten.
6. Schalten Sie den Backofen ab; Siehe "*So bedienen Sie den Backofen, Seite 19*".

Grill

1. Nehmen Sie sämtliches Zubehör (z. B. Backbleche und Gitterrost) aus dem Backofen heraus.
2. Schließen Sie die Backofentür.
3. Wählen Sie die höchste Temperatureinstellung; Siehe "*So bedienen Sie den Grill, Seite 26*".
4. Lassen Sie den Grill etwa 30 Minuten lang arbeiten.
5. Schalten Sie den Grill ab; Siehe "*So bedienen Sie den Grill, Seite 26*".



Bei der ersten Inbetriebnahme kann es über mehrere Stunden zu Rauch- und Geruchsentwicklung kommen. Dies ist völlig normal. Lüften Sie den Raum gut durch, damit Rauch und Gerüche schnell abziehen können. Atmen Sie die Dämpfe möglichst nicht ein.

5 Bedienung des Backofens

Allgemeine Hinweise zum Backen, Braten und Grillen



WARNUNG

Verbrennungsgefahr durch heiße Flächen!
Das Gerät kann sich im Betrieb stark aufheizen. Berühren Sie niemals heiße Brenner, das Innere des Backofens, Heizelemente und so weiter. Halten Sie Kinder fern.

Tragen Sie grundsätzlich hitzebeständige Schutzhandschuhe, wenn Sie etwas in den Backofen stellen oder herausnehmen.



GEFAHR:

Öffnen Sie die Backofentür vorsichtig: Heißer Dampf kann austreten.
Der austretende Dampf kann zu Verbrühungen von Händen, Gesicht und Augen führen.

Tipps zum Backen

- Benutzen Sie Metallgeschirr mit Antihafbeschichtung oder hitzebeständige Silikonformen.
- Nutzen Sie den Platz auf dem Gitterrost gut aus.
- Stellen Sie Backformen in die Mitte des Gitterrostes.
- Wählen Sie die richtige Einschubposition, bevor Sie Backofen oder Grill einschalten. Wechseln Sie die Einschubposition nicht, solange der Backofen heiß ist.
- Halten Sie die Backofentür geschlossen.

Tipps zum Rösten

- Eine Würzmischung aus Zitronensaft und schwarzem Pfeffer sorgt für eine besonders schmackhafte Zubereitung von ganzen Hühnern, Puten und größeren Fleischportionen.
- Fleisch mit Knochen braucht etwa 15 – 30 Minuten länger zum Garen als dieselbe Menge Fleisch ohne Knochen.
- Jeder Zentimeter an Fleischdicke braucht etwa 4 – 5 Minuten mehr an Garzeit.
- Lassen Sie Fleisch nach Ablauf der Garzeit noch etwa 10 Minuten im Backofen ruhen. Der Fleischsaft verteilt sich so gleichmäßiger im Braten und läuft beim Anschneiden nicht aus.
- Fisch stellen Sie auf einem hitzebeständigem Teller möglichst in der mittleren oder unteren Einschubposition in den Backofen.

Tipps zum Grillen

Fleisch, Geflügel und Fisch werden durch das Grillen schnell braun, bekommen eine schöne Kruste und

trocknen dabei nicht aus. Insbesondere flache Stücke, Fleischspieße und Würstchen sowie Gemüse mit hohem Wasseranteil (wie Tomaten oder Zwiebeln) sind zum Grillen gut geeignet.

- Verteilen Sie das Grillgut so auf dem Gitterrost, dass es nicht über die Kanten des Gitterrostes hinausragt.
- Schieben Sie den Gitterrost (mit darunter eingeschobener Tropfschale) in die richtige Einschubposition. Vergessen Sie nicht, die Tropfschale beim Grillen in den untersten Einschub einzuschieben, damit das Fett aufgefangen wird. Geben Sie etwas Wasser in die Tropfschale – so wird die Reinigung einfacher.



Lebensmittel, die nicht zum Grillen geeignet sind, können sich im schlimmsten Fall entzünden. Grillen Sie nur Lebensmittel, die bei der starken Hitze beim Grillen keinen Schaden nehmen.

Platzieren Sie das Grillgut nicht nahe der Backofenrückwand. Dort wird es besonders heiß, fettes Grillgut kann in Brand geraten.

So bedienen Sie den Backofen

Temperatur und Betriebsart einstellen

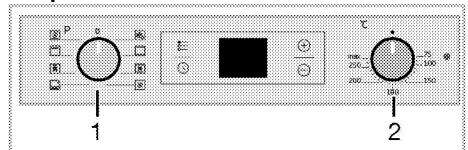

- 1 Funktionsknopf
- 2 Temperaturnopf

1. Stellen Sie den Funktionswähler auf die gewünschte Betriebsart ein.
2. Stellen Sie den Temperaturwähler auf die gewünschte Temperatur ein.

» Der Ofen heizt sich auf die eingestellte Temperatur auf und hält diese aufrecht. Während des Aufheizens bleibt die Temperaturleuchte eingeschaltet.

Backofen ausschalten

Bringen Sie Funktions- und Temperatureinstellungsknopf in die obere Position (Aus).

Einschubpositionen (bei Modellen mit Grillrost)

Es ist wichtig, dass der Grillrost richtig in die Einschübe eingesetzt wird. Setzen Sie den Grillrost wie in der Abbildung gezeigt in den Einschub ein.

Achten Sie darauf, dass der Grillrost nicht die Rückwand des Ofens berührt. Schieben Sie den Rost daher nur so weit ein, bis sich die Backofentür problemlos schließen lässt – so funktioniert der Grill am besten.

(Variiert je nach Produktmodell.)

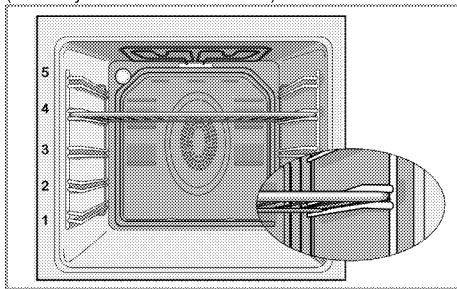

Betriebsarten

Die hier gezeigte Reihenfolge der Betriebsarten kann je nach Gerätemodell etwas abweichen.

Ober- und Unterhitze



Ober- und Unterhitze werden eingesetzt. Das Gargut wird gleichzeitig von oben und unten erhitzt. Diese Betriebsart eignet sich beispielsweise für Kuchen, Gebäck und Aufläufe. Nur ein Blech verwenden.

Unterhitze



Bei dieser Betriebsart wird lediglich das untere Heizelement eingesetzt. Geeignet z. B. für Pizza und zum Nachbräunen von unten.



Diese Funktion muss auch zur einfachen Dampfreinigung verwendet werden.

Umluft



Bei dieser Betriebsart werden Oberhitze, Unterhitze und der Lüfter (in der Rückwand) eingesetzt. Durch den Lüfter wird heiße Luft schnell gleichmäßig im Backofen verteilt. Nur ein Blech verwenden.

Auftauen



Der Backofen wird nicht beheizt. Nur der Lüfter (in der Rückwand) arbeitet. Gefrorene Lebensmittel werden langsam bei Raumtemperatur aufgetaut, heiße Lebensmittel abgekühlt.

Heißluft



Der Ringheizkörper (in der Rückwand) arbeitet.

Durch den Lüfter wird heiße Luft schnell gleichmäßig im Backofen verteilt. Ein Vorheizen ist meistens nicht erforderlich. Eignet sich zum Garen auf unterschiedlichen Einschubebenen. Mehrere Bleche können verwendet werden.



Diese Funktion muss auch zur einfachen Dampfreinigung verwendet werden.

„3D“-Funktion



Bei dieser Betriebsart werden Oberhitze, Unterhitze und Heißluft (hinteres Heizelement) eingesetzt. Das Gargut wird gleichmäßig und schnell von allen Seiten gegart. Nur ein Blech verwenden.

Grill, groß



Der große Grill an der Oberseite des Backofens ist in Betrieb. Diese Betriebsart eignet sich insbesondere zum Grillen größerer Fleischmengen.

- Stellen Sie mittelgroße bis große Portionen auf dem richtigen Einschub direkt unter das Grillelement.
- Stellen Sie die maximale Temperatur ein.
- Wenden Sie das Grillgut nach der Hälfte der Garzeit.

Grill + Umluft



Der Grilleffekt ist nicht so stark wie bei Flächengrill

- Kleine oder mittelgroße Portionen in der richtigen Einschubposition unter dem Grill-Heizkörper grillen.
- Stellen Sie die gewünschte Temperatur ein.
- Wenden Sie das Grillgut nach der Hälfte der Garzeit.

Ofenuhr verwenden

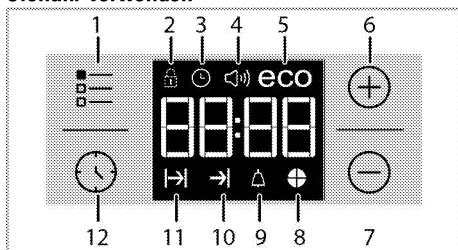





- 1 Einstelltaste
- 2 Tastensperre-Symbol
- 3 Uhrensymbol
- 4 Alarmlautstärkesymbol (Es ist bei Ihrem Modell möglicherweise nicht vorhanden.)
- 5 Energiesparmodusymbol
- 6 Plus-Taste
- 7 Minus-Taste
- 8 Zeit-Kuchendiagramm
- 9 Alarmsymbol
- 10 Garzeitensymbol
- 11 Garzeitsymbol
- 12 Programmtaste

	Die maximal einstellbare Zeit bis zum Garzeitende beträgt 5 Stunden 59 Minuten. Bei Stromausfällen wird die aktuelle Betriebsart aufgehoben. Sie müssen den Backofen also wieder neu einstellen.
	Wenn Sie Einstellungen ändern, blinken die entsprechenden Symbole in der Anzeige. Bitte warten Sie einen Moment ab, bis die Einstellungen in Kraft treten.
	Falls keine Gareinstellungen vorgenommen werden, kann die Uhrzeit nicht eingestellt werden.
	Bei eingestellter Garzeit wird die verbleibende Zeit angezeigt, sobald das Gerät arbeitet.

Garen mit Einstellung der Garzeit



Sie können den Ofen durch Vorgabe der Garzeit so einstellen, dass Ihr Gericht zu einer bestimmten Zeit servierbereit ist.



1. Wählen Sie die Funktion zum Garen.
2. Berühren Sie , bis das Symbol  für die Garzeit in der Anzeige erscheint.
3. Stellen Sie die Garzeit mit den Tasten  /  ein.
» » Nachdem Sie die Garzeit eingestellt haben, erscheinen das Symbol  und die Zeitscheibe kontinuierlich in der Anzeige.
4. Geben Sie das Gericht in den Ofen und stellen Sie die Temperatur über den Temperatorknopf ein.
Das Garen startet.

» Die am Display angezeigte Garzeit wird heruntergezählt, sobald das Garen beginnt und alle Teile der Zeitscheibe leuchten. Die eingestellte Garzeit wird in 4 gleiche Teile unterteilt; sobald die Zeit eines Teils abgelaufen, erlischt das Symbol dieses Teils. Dies zeigt übersichtlich das Verhältnis der verbleibenden Garzeit zur Gesamtgarzeit.

Ende der Garzeit verzögern:

Nach der Einstellung der Garzeit können Sie das Garzeitende auf einen späteren Zeitpunkt verschieben.

1. Wählen Sie die Funktion zum Garen.
2. Berühren Sie , bis das Symbol  für die Garzeit in der Anzeige erscheint.
3. Stellen Sie die Garzeit mit den Tasten  /  ein.
» » Sobald Sie die Garzeit eingestellt haben, erscheint das Symbol  kontinuierlich in der Anzeige.
4. Berühren Sie , bis das Symbol  für das Garzeitende in der Anzeige erscheint.
5. Stellen Sie das Garzeitende mit den Tasten  /  ein.

» Nachdem Sie die Garzeit eingestellt haben, erscheinen die Symbole  und  sowie die Zeitscheibe kontinuierlich in der Anzeige. Sobald das Garen startet, verschwindet das -Symbol.

6. Geben Sie das Gericht in den Ofen und stellen Sie die Temperatur über den Temperatorknopf ein.
Das Garen startet.

» Der Ofentimer berechnet die richtige Startzeit anhand von Garzeitende und Garzeit.

Beim Erreichen der Startzeit wird der ausgewählte Betriebsmodus automatisch eingestellt und der Ofen auf die festgelegte Temperatur vorgeheizt. Diese Temperatur wird bis zum Garzeitende beibehalten.
» Die am Display angezeigte Garzeit wird heruntergezählt, sobald das Garen beginnt und alle Teile der Zeitscheibe leuchten. Die eingestellte Garzeit wird in 4 gleiche Teile unterteilt; sobald die Zeit eines

Teils abgelaufen ist, erlischt das Symbol dieses Teils. Dies zeigt übersichtlich das Verhältnis der verbleibenden Garzeit zur Gesamtgarzeit.



7. Nach Abschluss des Garens erscheint „**End (Ende)**“ in der Anzeige, der Timer gibt einen Alarm aus.
8. Der Signalton erklingt 2 Minuten lang. Drücken Sie zum Beenden des Signaltons einfach eine beliebige Taste. Der Signalton verstummt, die aktuelle Zeit wird angezeigt.



Wenn Sie nach Abschluss des Alarms eine beliebige Taste drücken, schaltet sich der Ofen wieder ein. Drehen Sie Temperaturnopf und Funktionswähler zum Abschalten des Ofens in die Aus-Position (0); dadurch wird verhindert, dass sich der Ofen nach Abschluss des Alarms wieder einschaltet.

Tastensperre einschalten

Die Tastensperre verhindert die unerwünschte Bedienung des Ofens.

1. Berühren Sie , bis das Symbol  in der Anzeige erscheint.

» „**OFF (Aus)**“ erscheint in der Anzeige.



2. Drücken Sie zum Aktivieren der Tastensperre .

» Sobald die Tastensperre aktiviert ist, erscheint „**On (Ein)**“ in der Anzeige und das -Symbol leuchtet weiter.



Bei eingeschalteter Tastensperre sind die Bedientasten ohne Funktion. Auch nach einem Stromausfall bleibt die Tastensperre weiterhin eingeschaltet.

Deaktivierung der Tastensperre

1. Berühren Sie , bis das Symbol  in der Anzeige erscheint.

» „**On (Ein)**“ erscheint in der Anzeige.



2. Deaktivieren Sie die Tastensperre, indem Sie die Taste  drücken.

» Nach dem Abschalten der Tastensperre wird „**OFF (Aus)**“ angezeigt.

Alarmfunktion einstellen

Sie können die Alarmfunktion des Gerätes auch als Kurzzeitwecker einsetzen, wenn Sie sich an etwas erinnern lassen möchten.

Der Kurzzeitwecker hat keinen Einfluss auf die Funktionen des Backofens. Er wird lediglich zur Erinnerung eingesetzt. Dies ist beispielsweise sinnvoll, wenn Sie Speisen nach einer bestimmten Zeit wenden müssen. Nach Ablauf der voreingestellten Zeit gibt der Timer einen Alarm aus.

1. Berühren Sie , bis das Symbol  in der Anzeige erscheint.



Die Alarmfunktion kann auf maximal 23 Stunden und 59 Minuten eingestellt werden.

2. Stellen Sie die Alarmzeit mit  /  ein.



Funktionstasten für Alarmton, Uhrzeit, Anzeigehelligkeit und Temperaturtasten sollten auf Position 0 (Aus) eingestellt sein.

» Das -Symbol leuchtet weiter und die Alarmzeit erscheint in der Anzeige, sobald die Alarmzeit eingestellt ist.

3. Am Ende der Alarmzeit beginnt das -Symbol zu blinken und der Signalton wird ausgegeben.

Alarm abschalten

1. Der Signalton erklingt 2 Minuten lang. Drücken Sie zum Beenden des Signaltons einfach eine beliebige Taste.

» Der Signalton verstummt, die aktuelle Zeit wird angezeigt.

Alarm abbrechen



1. Zum Abbrechen des Alarms berühren Sie , bis das Symbol  in der Anzeige verschwindet.



2. Halten Sie die Taste  gedrückt, bis „**00:00**“ angezeigt wird.



Die Alarmzeit wird angezeigt. Falls Alarm- und Garzeit gleichzeitig eingestellt sind, wird die kürzere Zeiteinstellung angezeigt.

Signalton ändern

1. Berühren Sie , bis das Symbol  in der Anzeige erscheint.



2. Stellen Sie den gewünschten Signalton mit den Tasten  /  ein.

3. Der von Ihnen eingestellte Ton wird nach kurzer Zeit aktiviert.

» Der ausgewählte Alarmton wird mit „**b-01**“, „**b-02**“ oder „**b-03**“ angezeigt.

Uhrzeit ändern

So ändern Sie die zuvor eingestellte Uhrzeit:

1. Berühren Sie , bis das Symbol  in der Anzeige erscheint.

2. Stellen Sie die Uhrzeit mit den Tasten  /  ein.



3. Die von Ihnen eingestellte Zeit wird kurz darauf aktiviert.

Energiesparmodus



Mit dem Energiesparmodus können Sie während des Garens Energie sparen, indem Sie die Garzeit einstellen.

Dieser Modus schließt das Garen mit der Innentemperatur des Ofens ab, indem er die Heizelemente bereits vor Ablauf der Garzeit abschaltet.

Energiesparmodus einstellen



- Berühren Sie das Symbol , bis das **eco**-Symbol in der Anzeige erscheint.
- » „**OFF (Aus)**“ erscheint in der Anzeige.
- Aktivieren Sie den Energiesparmodus durch Berühren der -Taste.
- » Sobald der Energiesparmodus aktiviert ist, erscheint „**On (Ein)**“ in der Anzeige und das Energiesparen-Symbol leuchtet weiter.

Energiesparmodus deaktivieren

- Berühren Sie das Symbol , bis das **eco**-Symbol in der Anzeige erscheint.
- » „**On (Ein)**“ erscheint in der Anzeige.
- Deaktivieren Sie den Energiesparmodus durch Berühren der -Taste.
- » „**Off (Aus)**“ erscheint, sobald die der Energiesparmodus deaktiviert ist.

Displayhelligkeit einstellen

(Dieses Merkmal ist optional. Es ist bei Ihrem Modell möglicherweise nicht vorhanden.)

- Berühren Sie , bis „**d-01**“, „**d-02**“ oder „**d-03**“ für die Displayhelligkeit im Display erscheint.
 - Stellen Sie die gewünschte Helligkeit mit  /  ein.
- » Die von Ihnen eingestellte Displayhelligkeit wird kurz darauf aktiviert.

Garzeitentabelle

















Die Zeitangaben in dieser Tabelle sollen als Richtwerte dienen. Zeitangaben können aufgrund von Temperatur, Dicke, Typ der Lebensmittel und Ihren eigenen Vorlieben abweichen.

Backen und Braten



Der erste Einschub ist der **untere** Einschub.

Gericht	Backblechanzahl (Anzahl Einschübe)	Zu verwendendes Zubehör	Betriebsart	Einschubposition	Temperatur (°C)	Garzeit (ca.-Angabe in Min.)
Kuchen, Backblech	Ein Blech	Backblech*		3	160	25 ... 30
Kuchen, Form	Ein Blech	Kuchenform auf Rost**		2	180	40 ... 50
Kleine Kuchen	Ein Blech	Backblech*		3	160	25 ... 35
	Ein Blech	Backblech*		3	150	30 ... 40
	Zwei Bleche	1-Gebäckblech* 3-Backblech*		1 - 3	150	35 ... 50
	Drei Bleche	1-Backblech* 3-Gebäckblech* 5-Tiefes Backblech/Tropfschale*		1 - 3 - 5	150	35 ... 50
Biskuitkuchen	Ein Blech	Runde Springform mit einem Durchmesser von 26 cm auf Rost**		3	160	25 ... 35
	Ein Blech	Runde Springform mit einem Durchmesser von 26 cm auf Rost**		2	150	30 ... 40
	Zwei Bleche	1-Runde Springform mit einem Durchmesser von 26 cm auf Rost** 4-Runde Springform mit einem Durchmesser von 26 cm auf Gebäckblech**		1 - 4	150	35 ... 45
	Kekse	Ein Blech	Gebäckblech*		3	180
	Zwei Bleche	1-Gebäckblech* 3-Backblech*		1 - 3	180	30 ... 40
	Drei Bleche	1-Gebäckblech* 3-Backblech* 5-Tiefes Backblech/Tropfschale*		1 - 3 - 5	180	35 ... 45
Teiggebäck	Ein Blech	Backblech*		2	200	30 ... 40
	Zwei Bleche	1-Gebäckblech* 5-Backblech*		1 - 5	200	45 ... 55







	Drei Bleche	1-Gebäckblech* 3-Backblech* 5-Tiefes Backblech/Tropfschale*		1 - 3 - 5	200	55 ... 65
Teilchen	Ein Blech	Backblech*		2	200	25 ... 35
	Zwei Bleche	1-Gebäckblech* 3-Backblech*		1 - 3	200	35 ... 45
	Drei Bleche	1-Gebäckblech* 3-Backblech* 5-Tiefes Backblech/Tropfschale*		1 - 3 - 5	190	45 ... 55
Sauerteig	Ein Blech	Backblech*		2	200	35 ... 45
Lasagne	Ein Blech	Rechteckige Glas- /Metallform auf Rost**		2 - 3	200	30 ... 40
Pizza	Ein Blech	Backblech*		2	200 ... 220	15 ... 20
Rindersteak (ganz)/Braten	Ein Blech	Backblech*		3	25 Minute 250/max, dann 180 ... 190	100 ... 120
Lammkeule (Aufauf)	Ein Blech	Backblech*		3	25 Minute 250/max, dann 190	70 ... 90
	Ein Blech	Backblech*		3	25 Minute 250/max, dann 190	60 ... 80
Brathähnchen (1,0-2 kg)	Ein Blech	Backblech*		2	15 Minute 250/max, dann 180 ... 190	60 ... 80
	Ein Blech	Backblech*		2	15 Minute 250/max, dann 180 ... 190	60 ... 80
Pute (5-5 kg)	Ein Blech	Backblech*		1	25 Minute 250/max, dann 180 ... 190	150 ... 210
	Ein Blech	Backblech*		1	25 Minute 250/max, dann 180 ... 190	150 ... 210
Fisch	Ein Blech	Backblech*		3	200	20 ... 30
	Ein Blech	Backblech*		3	200	20 ... 30

Wir empfehlen, den Ofen grundsätzlich vorzuheizen.
* Dieses Zubehör wird möglicherweise nicht mit dem Produkt geliefert.
** Dieses Zubehör wird nicht mit dem Produkt geliefert. Handelsübliches Zubehör.

Zubereitungstabelle für Testgerichte

Gerichte in dieser Zubereitungstabelle werden entsprechend EN 60350-1 zubereitet, damit Prüfeinrichtungen das Gerät leichter testen können

Gericht	Backblechanzahl (Anzahl Einschübe)	Zu verwendendes Zubehör	Betriebsart	Einschubposition	Temperatur (°C)	Garzeit (ca.- Angabe in Min.)
Butterkekse	Ein Blech	Backblech*		3	140	20 ... 30
	Ein Blech	Backblech*		3	140	20 ... 30
	Zwei Bleche	1-Backblech* 3-Gebäckblech*		1 - 3	140	20 ... 30
	Drei Bleche	1-Backblech* 3-Gebäckblech* 5-Tiefes Backblech/Tropfschale*		1 - 3 - 5	140	25 ... 35
Kleine Kuchen	Ein Blech	Backblech*		3	160	25 ... 35
	Ein Blech	Backblech*		3	150	30 ... 40
	Zwei Bleche	1-Gebäckblech* 3-Backblech*		1 - 3	150	35 ... 50
	Drei Bleche	1-Backblech* 3-Gebäckblech* 5-Tiefes Backblech/Tropfschale*		1 - 3 - 5	150	35 ... 50

Gericht	Backblechanzahl (Anzahl Einschübe)	Zu verwendendes Zubehör	Betriebsart	Einschubposition	Temperatur (°C)	Garzeit (ca.-Angabe in Min.)
Biskuitkuchen	Ein Blech	Runde Springform mit einem Durchmesser von 26 cm auf Rost**		3	160	25 ... 35
	Ein Blech	Runde Springform mit einem Durchmesser von 26 cm auf Rost**		2	150	30 ... 40
	Zwei Bleche	1-Runde Springform mit einem Durchmesser von 26 cm auf Rost** 4-Runde Springform mit einem Durchmesser von 26 cm auf Gebäckblech**		1 - 4	150	35 ... 45
Apfelkuchen	Ein Blech	Rundes schwarzes Metallgeschirr mit einem Durchmesser von 20 cm auf Rost**		2	180	50 ... 60
	Ein Blech	Rundes schwarzes Metallgeschirr mit einem Durchmesser von 20 cm auf Rost**		2	170	50 ... 60
	Zwei Bleche	1-Rundes schwarzes Metallgeschirr mit einem Durchmesser von 20 cm auf Rost** 4-Rundes schwarzes Metallgeschirr mit einem Durchmesser von 20 cm auf Gebäckblech**		1 - 4	170	50 ... 60
Wir empfehlen, den Ofen grundsätzlich vorzuheizen. * Dieses Zubehör wird möglicherweise nicht mit dem Produkt geliefert. ** Dieses Zubehör wird nicht mit dem Produkt geliefert. Handelsübliches Zubehör.						

Tipps zum Kuchenbacken

- Falls Gebäck zu trocken wird, erhöhen Sie die Temperatur etwas und vermindern gleichzeitig die Garzeit.
- Werden Kuchen zu feucht, reduzieren Sie die Flüssigkeiten oder senken die Temperatur um 10 °C.
- Sofern die Oberseite des Kuchens zu stark gebräunt wird, backen Sie etwas länger mit reduzierter Temperatur.
- Wenn der Kuchen außen gut gelingt, innen jedoch noch klebrig ist, geben Sie weniger Flüssigkeit hinzu, senken die Temperatur und verlängern dafür die Garzeit etwas.

Tipps für Gebäck

- Falls Gebäck zu trocken wird, erhöhen Sie die Temperatur etwas und vermindern gleichzeitig die Garzeit. Befeuchten Sie den Teig mit einer Mischung aus Milch, Öl, Ei und Joghurt.
- Sollte Gebäck sehr lange zum Garen benötigen, achten Sie darauf, dass das Gebäck nicht über die Oberkante des Backblechs hinausragt.
- Wird Gebäck an der Oberseite gut gebräunt, innen jedoch nicht richtig gar, achten Sie darauf,

dass sich Flüssigkeiten nicht am Boden des Gebäcks konzentrieren. Versuchen Sie, Flüssigkeitsmischungen gleichmäßig zwischen den Teigschichten zu verteilen; so erreichen Sie eine gleichmäßige Bräunung.

 Halten Sie sich beim Backen an die Betriebsart- und Temperaturempfehlungen der Zubereitungstabelle. Falls die Unterseite nicht ausreichend gebräunt wird, nutzen Sie beim nächsten Mal den nächstniedrigeren Einschub.

Tipps zur Zubereitung von Gemüse

- Falls Gemüsegerichte zu trocken werden, bereiten Sie diese in einem Geschirr mit Deckel statt auf dem Blech zu. Geschlossene Behälter sorgen dafür, dass nicht zu viel Flüssigkeit verloren wird.
- Falls Gemüsegerichte nicht richtig gar werden, kochen Sie das Gemüse zuvor und geben es erst danach in den Ofen.

So bedienen Sie den Grill



WARNUNG

Backofentür beim Grillen geschlossen halten.
Verbrennungsgefahr durch heiße Flächen!

Grill einschalten

1. Drehen Sie den Funktionswähler auf das gewünschte Grillsymbol.
 2. Wählen Sie dann die gewünschte Grilltemperatur.
 3. Heizen Sie den Grill bei Bedarf etwa 5 Minuten vor.
- » Die Temperaturleuchte schaltet sich ein.

Grill ausschalten

1. Drehen Sie den Funktionswähler in die Aus-Position (oben).



Lebensmittel, die nicht zum Grillen geeignet sind, können sich im schlimmsten Fall entzünden. Grillen Sie nur Lebensmittel, die bei der starken Hitze beim Grillen keinen Schaden nehmen.
Platzieren Sie das Grillgut nicht nahe der Backofenrückwand. Dort wird es besonders heiß, fettes Grillgut kann in Brand geraten.

Garzeitentabelle zum Grillen

Elektrischer Grill

Speise	Zu verwendendes Zubehör	Einschubposition	Empfohlene Temperatur (°C)**	Grilldauer (ca.)
Fisch	Rost	4..5	250/max	20..25 Min. #
Hühnerklein	Rost	4..5	250/max	25...35 Min.
Lammkoteletts	Rost	4..5	250/max	20..25 Min.
Rinderbraten	Rost	4..5	250/max	25...30 Min. #
Kalbskoteletts	Rost	4..5	250/max	25..30 Min. #
Toastbrot *	Rost	4	250/max	1...3 min.

je nach Dicke

*5 Minuten vorheizen

**Falls die Grilltemperatur Ihres Produktes nicht angepasst werden kann, arbeitet der Grill mit Höchsttemperatur.

Gerichte in dieser Zubereitungstabelle werden entsprechend EN 60350-1 zubereitet, damit Prüfeinrichtungen das Gerät leichter testen können

Speise	Zu verwendendes Zubehör	Einschubposition	Temperatur (°C)	Garzeit (ca. - Angabe in Min.)
Toast	Rost	4	250/max	1..3 Minute
Frikadellen (Rindfleisch) - 12 Stücke	Rost	4	250/max	25...35 Minute



Wenden Sie die Speise nach 2/3 der gesamten Grillzeit.

Wir empfehlen, das Gerät bei allen Lebensmitteln 5 bis 6 Minuten lang vorheizen zu lassen.

6 Reinigung und Wartung

Allgemeine Hinweise

Durch regelmäßiges Reinigen verlängern Sie die Lebenserwartung Ihres Gerätes und beugen Fehlfunktionen vor.

	GEFAHR: Trennen Sie das Gerät von der Stromversorgung, bevor Sie es reinigen. Es besteht Stromschlaggefahr!
	GEFAHR: Lassen Sie das Gerät vor dem Reinigen gründlich abkühlen. Verbrennungsgefahr durch heiße Flächen!

- Reinigen Sie das Gerät nach jedem Gebrauch gründlich. Dadurch lassen sich Speisereste leichter entfernen und können beim nächsten Einsatz des Gerätes nicht einbrennen.
- Zur Reinigung benötigen Sie keine Spezialreiniger. Verwenden Sie am besten warmes Wasser mit etwas herkömmlichem Reiniger, ein weiches Tuch oder einen Schwamm. Anschließend mit einem Tuch trocknen.
- Achten Sie stets darauf, überschüssige und verschüttete Flüssigkeiten nach der Reinigung gründlich ab- bzw. aufzuwischen.
- Wenn Sie Edelstahl und Griffe reinigen verzichten Sie auf Reinigungsmittel, die Säuren oder Chlor enthalten. Reinigen Sie diese Teile mit einem weichen Tuch und etwas Flüssigreiniger (kein Scheuermittel); wischen Sie dabei am besten nur in eine Richtung.

	Durch bestimmte Reinigungsmittel können die Oberflächen des Gerätes beschädigt werden. Verwenden Sie keine aggressiven Reinigungsmittel, keine Scheuermittel und keine scharfen oder spitzen Gegenstände bei der Reinigung.
---	---

	Nutzen Sie keine Dampfreiniger zur Reinigung des Gerätes – es besteht Stromschlaggefahr.
--	--

Bedienfeld reinigen

Reinigen Sie Bedienfeld und Knöpfe mit einem feuchten Tuch; anschließend trocken reiben.

	Falls Ihr Produkt mit mechanischen Tasten oder Knöpfen ausgestattet ist, ziehen Sie die diese zum Reinigen des Bedienfelds nicht ab. Das Bedienfeld kann beschädigt werden!
--	---

Backofen reinigen

So reinigen Sie die Seitenwand (Variiert je nach Produktmodell.)

(Dieses Merkmal ist optional. Es ist bei Ihrem Modell möglicherweise nicht vorhanden.)

1. Lösen Sie den vorderen Bereich der seitlichen Halterungen, indem Sie diese von der Seitenwand wegziehen.
2. Ziehen Sie die seitliche Halterung komplett zu sich hin heraus.

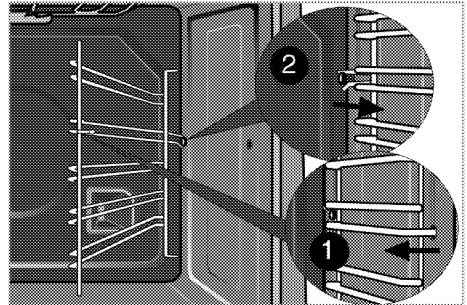

Katalytische Seitenwände

(Dieses Merkmal ist optional. Es ist bei Ihrem Modell möglicherweise nicht vorhanden.)

Seitenwände (A) und/oder Rückwand (B) Ihres Produktes können mit katalytischer Emaille beschichtet sein. Die katalytischen Wände haben eine helle matte Farbe und eine poröse Oberfläche. Die katalytischen Seitenwände des Backofens sollten nicht gereinigt werden. Die poröse Oberfläche der katalytischen Wände reinigt sich durch Absorbierung und Umwandlung von Rückständen (Dampf und Kohlendioxid) von selbst.

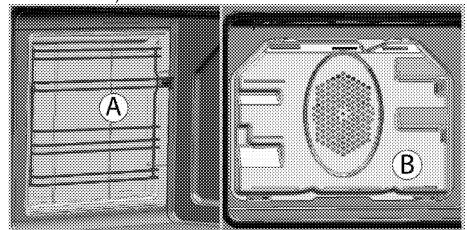

SimpleSteam Reinigung

Diese Funktion gewährleistet eine einfache Reinigung, da Schmutz (der durch langes Warten eingetrocknet ist) mit dem im Inneren des Backofens entstehenden Dampf und den an den Innenflächen des Backofens kondensierenden Wassertropfen aufgeweicht wird.

1. Entfernen Sie sämtliches Zubehör aus dem Garraum.

2. Gießen Sie 500 ml Wasser in das Blech und platzieren Sie es im 2. Einschub des Ofens.

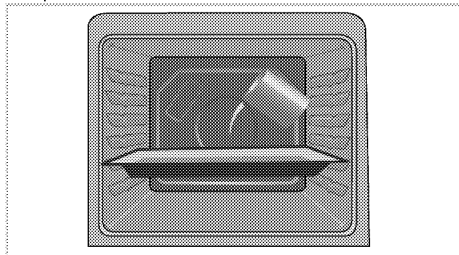

3. Stellen Sie den Backofen auf einfache Dampfreinigung ein, lassen Sie ihn bei 100 °C 25 Minuten laufen.
4. Öffnen Sie die Tür, wischen Sie die Innenflächen des Backofens mit einem feuchten Schwamm oder Tuch ab.
5. Verwenden Sie zum Entfernen von hartnäckigem Schmutz am besten warmes Wasser mit etwas herkömmlichem Reiniger, ein weiches Tuch oder einen Schwamm und ein Tuch zum Trockenreiben.

i Während des Dampfreinigungsmodus verdampft Wasser, das zum Aufweichen von Verschmutzungen und Verkrustungen im Garraum auf das Blech gegeben wurde. Dadurch entsteht eine beabsichtigte Kondensation im Garraum und am Innenglas der Ofentür und kann Wasser heruntertropfen, wenn Sie die Ofentür öffnen. Wischen Sie den Ofen nach Öffnen der Tür gründlich trocken.

Backofentür reinigen

Verwenden Sie zum Reinigen der Backofentür am besten warmes Wasser mit etwas herkömmlichem Reiniger, ein weiches Tuch oder einen Schwamm. Anschließend mit einem Tuch trocknen.

i Verzichten Sie bei der Reinigung der Backofentür auf aggressive Reinigungsmittel und auf scharfkantige Schaber aus Metall. Solche Hilfsmittel können die Oberflächen zerkratzen und das Glas beschädigen.

Backofentür ausbauen

1. Öffnen Sie die Backofentür (1).
2. Öffnen Sie die Clips am Scharniergehäuse links und rechts der Backofentür, indem Sie diese wie in der Abbildung gezeigt nach unten drücken.

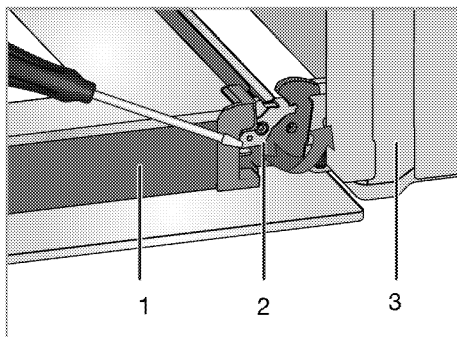

- 1 Tür
- 2 Scharniersperre (geschlossene Position)
- 3 Ofen
- 4 Scharniersperre (geöffnete Position)

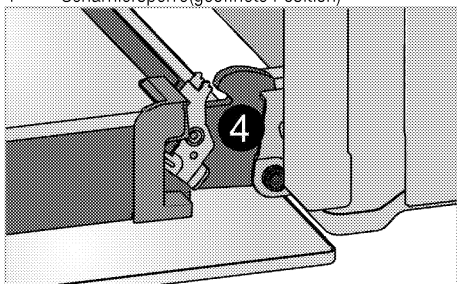

3. Öffnen Sie die Backofentür zur Hälfte.

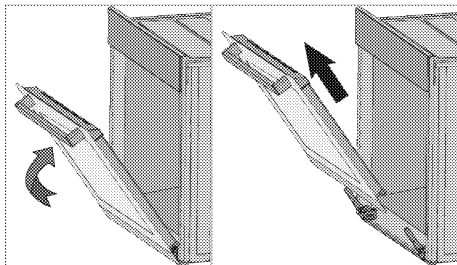

4. Nehmen Sie die Ofentür heraus, indem Sie diese etwas anheben und von den Scharnieren rechts und links lösen.

i Zum Einbau führen Sie die obigen Schritte wieder in umgekehrter Reihenfolge aus. Vergessen Sie nicht, die Clips am Scharniergehäuse nach dem Wiedereinsetzen der Tür wieder zu schließen.

Türinnenscheibe ausbauen

(Dieses Merkmal ist optional. Es ist bei Ihrem Modell möglicherweise nicht vorhanden.)

Die Türinnenscheibe kann zur Reinigung ausgebaut werden.

Öffnen Sie die Backofentür.

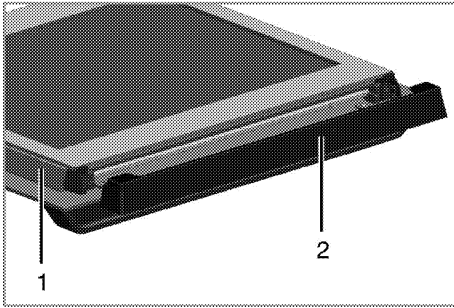

- 1 Rahmen
- 2 Kunststoffteil

Ziehen Sie das im oberen Bereich der Fronttür installierte Kunststoffteile zu sich heraus.

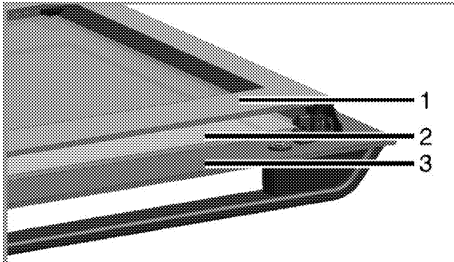

- 1 Innerste Scheibe
- 2 Innenscheibe
- 3 Äußere Glasscheibe
- 4 Scheibenkunststoffschlitz, unten

Heben Sie die innerste Scheibe (1) wie in der Abbildung gezeigt leicht in Richtung **A** an, ziehen Sie sie in Richtung **B** heraus.

Wiederholen Sie dieses Verfahren zum Entfernen der inneren Scheibe (2).

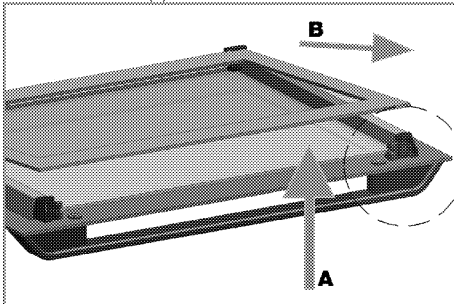

Der erste Schritt zum Zusammensetzen der Tür besteht darin, die Innenscheibe (2) wieder anzubringen.

Platzieren Sie die abgeschrägte Ecke der Scheibe wie in der Abbildung gezeigt so, dass sie in der abgeschrägten Ecke des Kunststoffschlitzes aufliegt.

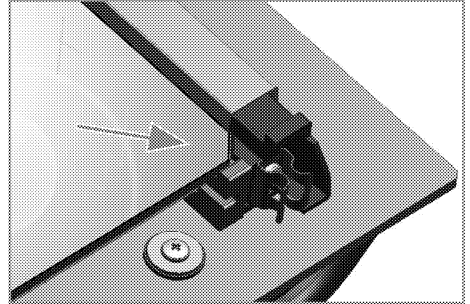

Die Innenscheibe (2) muss im Kunststoffschlitz in der Nähe der innersten Scheibe (1) installiert werden. Achten Sie bei der Anbringung der innersten Scheibe (1) darauf, dass die bedruckte Seite der Scheibe in Richtung der inneren Scheibe zeigt.

Es ist wichtig, die untere Kante der inneren Scheibe im unteren Kunststoffschlitz einzusetzen.

Drücken Sie das Kunststoffteil gegen den Rahmen, bis es mit einem Klickgeräusch einrastet.

Beleuchtung des Backofens auswechseln



GEFAHR:

Bevor Sie die Beleuchtung des Backofens auswechseln, sorgen Sie dafür, dass das Gerät vollständig von der Stromversorgung getrennt und komplett abgekühlt ist; ansonsten droht Verbrennungs- und Stromschlaggefahr.
Verbrennungsgefahr durch heiße Flächen!



Als Leuchtmittel wird eine spezielle Glühlampe eingesetzt, die für Temperaturen bis 300 °C ausgelegt ist. Weitere Hinweise finden Sie in "Technische Daten, Seite 12". Passende Leuchtmittel erhalten Sie beim autorisierten Kundendienst.



Die Position der Beleuchtung kann etwas von der Abbildung abweichen.



Die in diesem Gerät verwendete Lampe ist nicht zur Raumbeleuchtung geeignet. Der vorgesehene Zweck dieser Lampe besteht darin, dass der Nutzer Lebensmittel besser sehen kann.



Die in diesem Gerät verwendeten Lampen müssen extremen physikalischen Bedingungen, wie Temperaturen über 50 °C standhalten.

Wenn Ihr Ofen mit einer runden Leuchte ausgestattet ist:

1. Trennen Sie das Gerät vollständig von der Stromversorgung.
2. Schrauben Sie die Glasabdeckung gegen den Uhrzeigersinn ab.

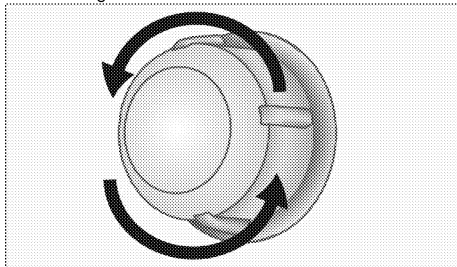

3. Wenn es sich bei Ihrer Ofenlampe um den in der nachstehenden Abbildung gezeigten Typ (A) handelt, drehen Sie sie wie abgebildet heraus und wechseln Sie sie. Falls sie vom Typ (B) ist, ziehen Sie sie wie abgebildet heraus und wechseln Sie sie.

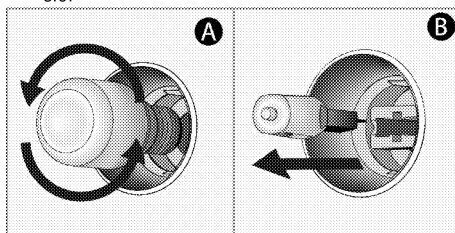

4. Glasabdeckung wieder anbringen.

7 Problemlösungen

Aus dem Backofen tritt im Betrieb Dampf aus.

- Während des Betriebs ist ein Dampfaustritt normal. >>> *Dies ist kein Fehler.*

Beim Aufheizen und Abkühlen sind metallische Geräusche zu hören.

- Wenn sich die Temperatur von Metallteilen ändert, dehnen sich diese aus oder ziehen sich zusammen – dabei entstehen Geräusche. >>> *Dies ist kein Fehler.*

Das Gerät funktioniert nicht.

- Die Sicherung ist durchgebrannt oder ausgelöst. >>> *Kontrollieren Sie die Sicherungen im Sicherungskasten. Bei Bedarf austauschen oder zurücksetzen.*
- Das Gerät ist nicht richtig an die (geerdete) Steckdose angeschlossen. >>> *Überprüfen Sie die Steckerverbindung.*

Die Ofenbeleuchtung funktioniert nicht.

- Das Leuchtmittel ist defekt. >>> *Tauschen Sie das Leuchtmittel aus.*
- Die Stromversorgung wurde unterbrochen. >>> *Überprüfen Sie die Stromversorgung. Kontrollieren Sie die Sicherungen im Sicherungskasten. Sicherungen bei Bedarf austauschen oder zurücksetzen.*

Backofen heizt nicht.

- Passende Garfunktion und/oder Temperatur nicht eingestellt. >>> *Stellen Sie den Ofen auf die richtige Garfunktion und/oder Temperatur ein.*
- Bei Modellen mit Timer ist der Timer eventuell nicht richtig eingestellt. >>> *Stellen Sie die richtige Zeit ein.*
(Bei Produkten mit Mikrowellenofen kontrolliert der Timer nur die Mikrowelle.)
- Die Stromversorgung wurde unterbrochen. >>> *Überprüfen Sie die Stromversorgung. Kontrollieren Sie die Sicherungen im Sicherungskasten. Sicherungen bei Bedarf austauschen oder zurücksetzen.*

(Bei Modellen mit Timer:) Die Uhrzeitanzeige blinkt oder das Uhrensymbol leuchtet.

- Es gab einen Stromausfall. >>> *Stellen Sie die aktuelle Uhrzeit ein, schalten Sie das Gerät aus und anschließend wieder ein.*



Falls sich ein Problem nicht mit den obigen Hinweisen lösen lassen sollte, wenden Sie sich bitte an den autorisierten Kundendienst oder an den Händler, bei dem Sie das Gerät gekauft haben. Versuchen Sie niemals, ein defektes Gerät selbst zu reparieren.

Forno incorporado

Manual do utilizador

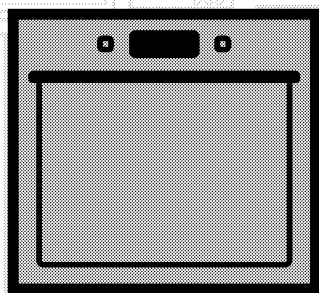

PT

beko

Em primeiro lugar, por favor, leia este manual!

Caro Cliente,

Obrigado por preferir um produto Beko. Esperamos que consiga obter os melhores resultados do seu produto, o qual foi fabricado com alta qualidade e tecnologia de ponta. Entretanto, leia totalmente este manual do utilizador e todos os outros documentos que o acompanham antes de utilizar o produto e guarde-o para qualquer consulta posterior.

Se transferir o produto para outra pessoa, entregue também o manual do utilizador. Atente a todos os avisos e informações deste manual do utilizador.

Lembre-se que este manual poderá também ser aplicável para vários outros modelos. As diferenças entre os modelos estarão identificadas no manual.

Explicação dos símbolos

Ao longo deste manual do utilizador são utilizados os seguintes símbolos:

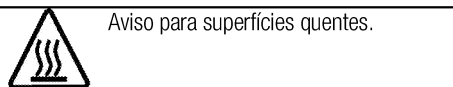
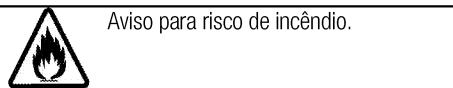
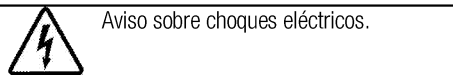
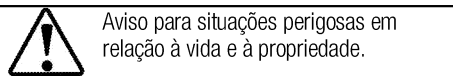
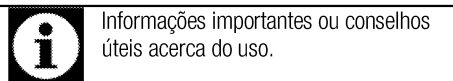

Arçelik A.Ş.
Karaağaç caddesi No:2-6
34445 Sütlüce/Istanbul/TURKEY
Made in TURKEY

1 Avisos e instruções importantes
sobre segurança e meio-ambiente 4

Segurança geral	4
Segurança eléctrica	4
Segurança do produto	5
Utilização pretendida	7
Segurança para crianças	8
Eliminação do produto velho	8
Eliminação do material da embalagem	8
Eliminação do produto velho	8

2 Informação geral 9

Visão geral	9
Conteúdo da embalagem	10
Especificações técnicas	11

3 Instalação 12

Instalação prévia	12
Instalação e ligação	14

4 Preparações 16

Conselhos para poupar energia	16
Uso inicial	16
Ajuste da hora	16
Primeira limpeza da unidade	16
Aquecimento inicial	16

5 Funcionar com o forno 18

Informações gerais sobre cozer, assar e grelhar no forno	18
Como usar o forno eléctrico	18
Modos de funcionamento	19
Usar o relógio do forno	20
Tabela de tempos de cozedura	22
Operar o grelhador	25
Tabelas de tempos de cozedura para grelhar	25

6 Manutenção e cuidados 27

Informações gerais	27
Limpar o painel de controlo	27
Limpar o forno	27
Remover a porta do forno	28
Remover o vidro interno da porta	28
Substituir a lâmpada do forno	29

7 Resolução de problemas 31

1 Avisos e instruções importantes sobre segurança e meio-ambiente

Esta secção contém importantes instruções sobre segurança que lhe ajudarão a evitar perigos de ferimentos pessoais ou danos à propriedade. O desrespeito a estas instruções poderá invalidar a garantia.

Segurança geral

- Este equipamento pode ser usado por crianças maiores de 8 anos e por pessoas com capacidades físicas, sensoriais ou mentais reduzidas ou sem experiência e conhecimento, desde que lhes sejam dadas supervisão e instrução sobre o uso do equipamento de forma segura e entendam os perigos envolvidos. As crianças não devem brincar com o equipamento. A limpeza e manutenção a cargo do utilizador não devem ser realizadas por crianças sem supervisão.
- O aparelho não se destina a ser utilizado por pessoas (incluindo crianças) com capacidades físicas, mentais ou sensoriais reduzidas, ou sem experiência e conhecimento, exceto se forem supervisionadas ou receberem instruções. As crianças devem ser supervisionadas de modo a não brincarem com o aparelho.

- Se o produto for passado a outra pessoa para utilização pessoal ou em segunda mão, o manual do utilizador, as etiquetas do produto e outros documentos relevantes devem ser também entregues.
- Os procedimentos de instalação e reparação devem ser sempre realizados por agentes da assistência autorizada. O fabricante não deve ser responsabilizado por danos oriundos de procedimentos realizados por pessoas não autorizadas que podem invalidar a garantia. Antes da instalação, leia cuidadosamente as instruções.
- Não ligue o produto se houver algum defeito ou dano visível.
- Certifique-se de desligar os botões de funcionamento do produto após cada utilização.

Segurança eléctrica

- Se o produto tiver uma falha, ele não deverá ser operado a não ser que seja reparado pelo Agente de Assistência Autorizado. Há risco de choque eléctrico!
- Apenas ligue o produto a uma tomada/linha com terra com a voltagem e a orotecção como especificado nas "Especificações técnicas". A instalação à terra

deve ser realizada por um electricista qualificado, ao usar o produto com ou sem um transformador. A nossa empresa não deverá ser responsabilizada por quaisquer problemas que surjam devido ao produto não ter sido ligado à terra de acordo com os regulamentos locais.

- Nunca lave o produto derramando ou vertendo água sobre ele! Há risco de choque eléctrico!
- Nunca toque na ficha com as mãos molhadas! Nunca retire a ficha da tomada puxando pelo cabo, puxe sempre agarrando a ficha.
- O produto não deverá estar com a ficha ligada à tomada durante os procedimentos de instalação, de manutenção, de limpeza e de reparação.
- Se o cabo de ligação à alimentação para o produto estiver danificado, deverá ser substituído pelo fabricante, pelo seu agente de assistência ou por pessoas igualmente qualificadas para evitar um perigo.
- O equipamento deverá ser instalado de modo a que possa ser totalmente desligado da rede. A separação deverá ser fornecida por uma ficha de corrente ou por um interruptor integrado na instalação eléctrica fixa, de

acordo com os regulamentos de construção.

- A superfície traseira do forno fica muito quente quando em utilização. Certifique-se de que a ligação do eléctrica não contacte a superfície traseira; caso contrário, as ligações podem ficar danificadas.
- Não comprima o cabo de alimentação entre a porta do forno e a estrutura e não o passe por cima de superfícies quentes. Caso contrário, o isolamento do cabo pode derreter e provocar incêndio, como resultado de um curto-circuito.
- Qualquer tarefa com sistemas e equipamentos eléctricos deve ser executada por pessoas qualificadas e autorizadas.
- Em caso de algum dano, desligue o produto e corte a alimentação eléctrica. Para fazer isso, desligue o fusível doméstico.
- Certifique-se de que a potência do fusível seja compatível com o produto.

Segurança do produto

- **AVISO:** O aparelho e as suas partes acessíveis tornam-se quentes durante a utilização. Procure evitar tocar nos elementos de aquecimento. Crianças menores de 8 anos devem ser afastadas, a menos

que estejam sob supervisão constante.

- Nunca utilize o produto quando o seu raciocínio ou coordenação estiverem debilitados pelo uso de álcool e/ou medicamentos.
- Tenha cuidado quando usar bebidas alcoólicas nos seus pratos. O álcool evapora-se a altas temperaturas e pode provocar incêndio, já que se incendeia quando entra em contacto com superfícies quentes.
- Não coloque materiais inflamáveis junto do produto, pois os seus lados podem ficar quentes durante a utilização.
- Durante a utilização o aparelho aquece. Procure evitar tocar nos elementos de aquecimento dentro do forno.
- Mantenha todas as ranhuras de ventilação desobstruídas.
- Não aqueça latas fechadas e jarras de vidro no forno. A pressão que se pode acumular na lata/jarra pode fazer com que expluda.
- Não coloque tabuleiros para cozer no forno, pratos ou folhas de alumínio directamente no fundo do forno. A acumulação do calor poderá danificar o fundo do forno.
- Não use limpadores abrasivos ásperos ou raspadores de metal duros para limpar a porta de vidro

do forno, já que podem riscar a superfície, o que pode resultar em rachadura do vidro.

- Não use limpadores a vapor para limpar o aparelho, já que podem provocar um choque eléctrico.
- (Varia dependendo do modelo do produto.)

Colocar correctamente a prateleira de arame e o tabuleiro nos suportes de arame

É importante colocar a prateleira e/ou tabuleiro correctamente no suporte. Deslize a prateleira de arame ou o tabuleiro entre os 2 frisos e certifique-se que está estável antes de colocar algum alimento sobre a mesma (consulte a figura seguinte).

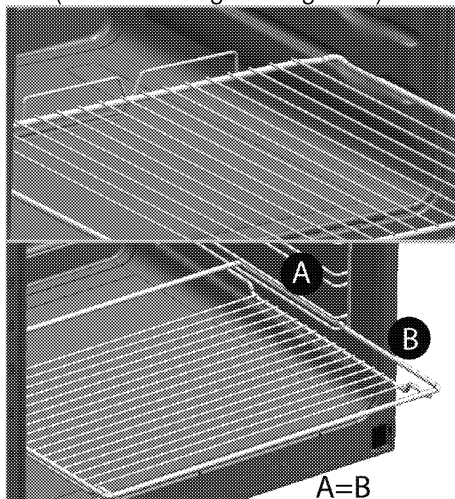

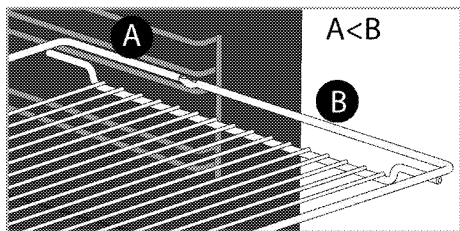

- Não utilize o produto se o vidro da porta da frente estiver removido ou quebrado.
- Esta pêga não é um secador de toalhas. Não pendure toalhas, luvas ou produtos têxteis similares quando a função grelhador estiver com a porta aberta.
- Use sempre luvas para forno resistentes ao calor quando colocar ou retirar os pratos no/do forno quente.
- Coloque o papel vegetal no recipiente ou no acessório do forno (tabuleiro, grelha de arame, etc.) juntamente com os alimentos e depois introduza tudo no forno pré-aquecido. Remova as partes em excesso do papel vegetal que estejam a extravasar do acessório ou do recipiente, para evitar o risco de que toquem os elementos de aquecimento do forno. Nunca use o papel vegetal numa temperatura de funcionamento superior à que é indicada para o papel. Não coloque o papel vegetal diretamente na base do tabuleiro.

- **AVISO:** Verifique se o cabo de alimentação do aparelho está desligado ou o quadro de distribuição está desligado antes de substituir a lâmpada, para evitar a possibilidade de choque elétrico.
- O aparelho não deve ser instalado atrás de uma porta decorativa para evitar sobreaquecimento.

Para que a chama funcione correctamente:

- Certifique-se que a ficha está bem encaixada na tomada e que não provoque faísca.
- Não utiliza um cabo danificado, cortado ou com extensão, mas apenas o cabo original.
- Verifique se não há líquidos ou humidade na tomada em que o produto é ligado.

Utilização pretendida

- Este produto foi concebido para utilização doméstica. O uso comercial não é admissível.
- **CUIDADO:** Este equipamento destina-se apenas a cozedura. Não deve ser usado para outros fins, como por exemplo, aquecimento do cómodo."
- Este produto não deverá ser usado para aquecer pratos por baixo do grelhador, secar toalhas e panos de prato, etc., pendurando-os nos manípulos e para fins de aquecimento.

- O fabricante não será responsável por qualquer dano causado por uso ou manuseamento incorrectos.
- O forno pode ser usado para descongelar, assar e grelhar alimentos.

Segurança para crianças

- **AVISO:** As partes acessíveis podem tornar-se quentes durante a utilização. As crianças deverão ser mantidas afastadas.
- Os materiais da embalagem serão perigosos para as crianças. Mantenha os materiais de embalagem afastados das crianças. Por favor, elimine todas as partes da embalagem de acordo com as normas ambientais.
- Os produtos eléctricos são perigosos para as crianças. Mantenha as crianças afastadas do produto quando em funcionamento e não as deixe brincar com o mesmo.
- Não coloque quaisquer itens por cima do equipamento que as crianças possam alcançar.
- Quando a porta estiver aberta, não coloque qualquer objecto pesado sobre ela e não permita que as crianças se sentem sobre ela. Pode virar ou pode danificar as dobradiças.

Eliminação do produto velho

Conformidade com a Directiva WEEE e Eliminação de Resíduos:



Este produto está em conformidade com a Directiva WEEE da UE (2012/19/EU). Este produto porta um símbolo de classificação para resíduos de equipamentos eléctricos e electrónicos (WEEE). Este produto foi fabricado com materiais e peças de alta qualidade, que podem ser reutilizados e reciclados. No fim da sua vida útil, não elimine o resíduo com o lixo doméstico normal ou outro lixo. Leve-o a um centro de recolha para reciclagem de equipamentos eléctricos e electrónicos. Consulte as autoridades locais para se informar sobre estes centros de recolha.

Cumprimento com a Directiva RoHS:

O produto que adquiriu está em conformidade com a Directiva RoHS da UE (2011/65/EU). Ele não contém materiais perigosos e proibidos especificados na Directiva.

Eliminação do material da embalagem

- Os materiais da embalagem são perigosos para as crianças. Mantenha os materiais no lugar seguro fora do alcance das crianças. Os materiais da embalagem do produto são fabricados a partir de materiais reciclados. Elimine-os de forma adequada e separe-os de acordo com as instruções de lixo reciclado. Não os elimine com o lixo doméstico normal.

Eliminação do produto velho

- Guarde a caixa original do produto e transporte nela o produto. Siga as instruções expressas na caixa. Se não tiver a caixa original, embrulhe o produto em plástico de bolha ou cartão grosso e passe fita adesiva para o prender firmemente.
- Para impedir que a grelha de arame e o tabuleiro dentro do forno danifiquem a porta do forno, coloque uma tira de cartão por dentro da porta do forno, nos locais que coincidem com a posição dos tabuleiros. Passe fita adesiva sobre a porta do forno até às partes laterais.
- Não utilize a porta ou o manípulo para levantar ou mover o produto.



Não pouse qualquer objecto sobre o produto e desloque-o na posição vertical.



Verifique a aparência geral do seu produto para verificar se existem alguns danos que possam ter ocorrido durante o transporte.

2 Informação geral

Visão geral

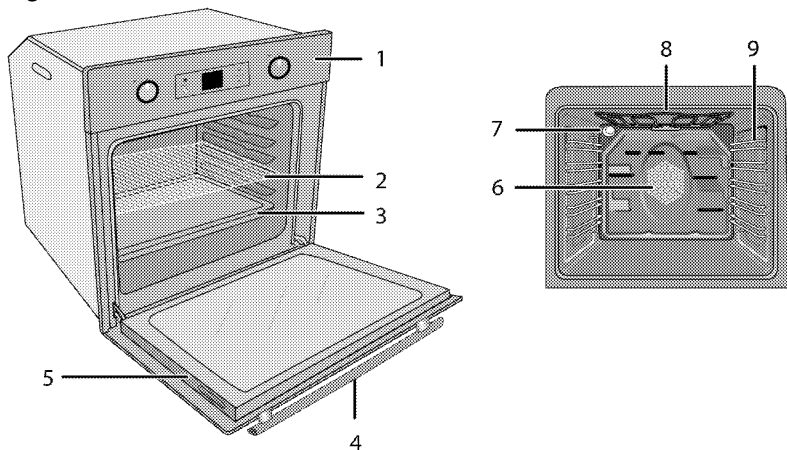

- 1 Painel de controlo
- 2 Prateleira de arame
- 3 Tabuleiro
- 4 Pega
- 5 Porta

- 6 Motor da ventoinha (disco de aço por detrás)
- 7 Lâmpada
- 8 Elemento de aquecimento superior
- 9 Posições da prateleira

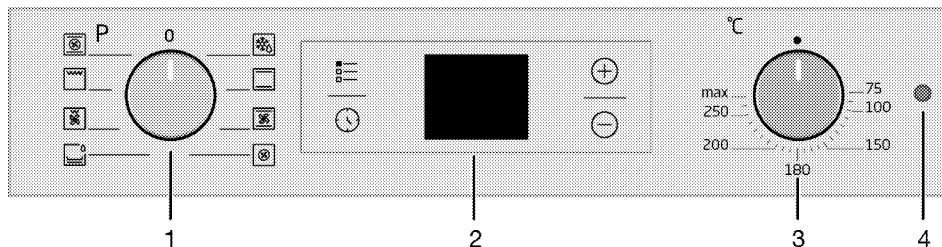

- 1 Botão da função
- 2 Temporizador digital

- 3 Botão do termostato
- 4 Lâmpada do termostato

Conteúdo da embalagem



Os acessórios fornecidos podem variar dependendo do modelo do produto. Nem todos os acessórios descritos no manual do utilizador poderão fazer parte do seu produto.

1. Manual do utilizador

2. Tabuleiro padrão

Usado para pastelaria, alimentos congelados e grandes assados.

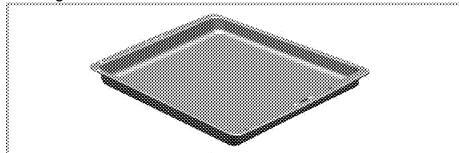

3. Tabuleiro para doces

Usado para pastelaria, como bolos e biscoitos.

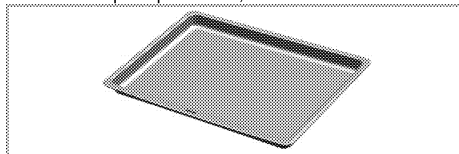

4. Grelha de arame

Usada para assar e para colocar o alimento a ser estufado, assado ou cozinhado em caçarolas, na prateleira desejada.

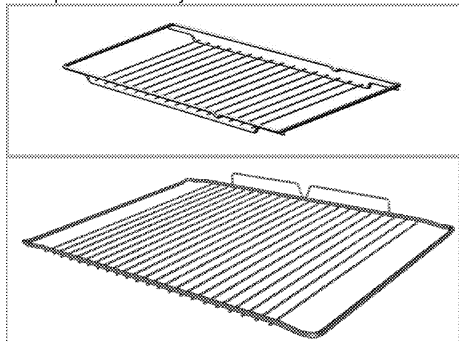

5. Colocar correctamente a prateleira de arame e o tabuleiro nas prateleiras telescópicas (Esta funcionalidade é opcional. Poderá não fazer parte do seu produto.)

As prateleiras telescópicas permitem-lhe instalar e remover facilmente os tabuleiros e a prateleira de arame.

Ao usar o tabuleiro e a prateleira de arame com prateleiras telescópicas, certifique-se de que os pinos na parte traseira da prateleira telescópica oponha-se às extremidades da prateleira e do tabuleiro.

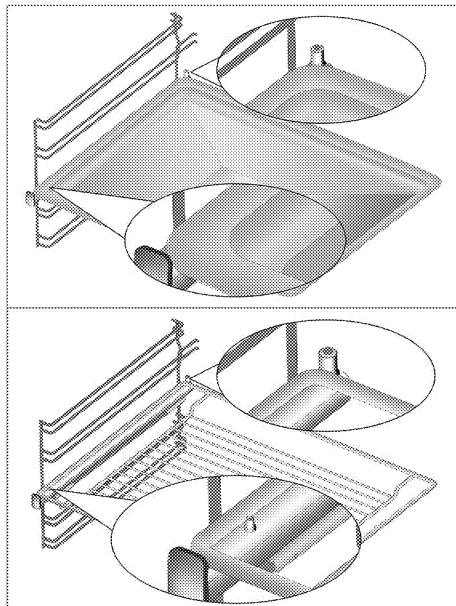

Especificações técnicas

Voltagem/frequência	220-240 V ~ 50 Hz
Consumo total de energia	2.5 kW
Tipo de cabo / secção	min.H05W-FG 3 x 1,5 mm ²
Dimensões externas (altura / largura / profundidade)	595 mm/594 mm/567 mm
Dimensões da instalação (altura/largura/profundidade)	**590 ou 600 mm/560 mm/min. 550 mm
Forno principal	Forno multifunções
Lâmpada interior	15/25 W
Consumo de energia do grelhador	2.2 kW

Coisas essenciais: A informação no rótulo de energia dos fornos eléctricos é dada de acordo com a norma EN 60350-1 / IEC 60350-1. Esses valores são determinados sob a carga padrão com as funções do aquecedor inferior-superior ou do aquecimento assistido por ventoinha (caso exista).

A classe de eficiência energética é determinada de acordo com a seguinte polarização dependendo da existência ou não de funções relevantes no produto. 1-Cozinhar com ventoinha-eco, 2- Cozinhar a turbo lento, 3- Cozinhar a turbo, 4- Aquecimento inferior/superior assistido por ventoinha, 5-Aquecimento superior e inferior.



As especificações técnicas poderão ser alteradas sem aviso prévio para melhorar a qualidade do produto.



As figuras neste manual são esquemáticas e poderão não corresponder exactamente ao seu produto.



Os valores apresentados nos rótulos do produto ou na documentação que o acompanha são obtidos em condições de laboratório de acordo com as normas relevantes. Dependendo das condições ambientais e operacionais do produto, estes valores poderão variar.

3 Instalação

O produto deve ser instalado por pessoal qualificado, conforme os regulamentos vigentes. Caso contrário, a garantia ficará sem efeito. O fabricante não deve ser responsabilizado por danos oriundos de procedimentos realizados por pessoas não autorizadas e pode invalidar a garantia.



A preparação do local e a instalação eléctrica para o produto é da responsabilidade do cliente.



PERIGO:

O produto deverá ser instalado de acordo com todas as normas locais sobre equipamentos a gás e/ou eléctricos.



PERIGO:

Antes da instalação, verifique visualmente se o produto possui algum defeito. Se tal for o caso, não permita a sua instalação. Os produtos danificados provocam riscos para a sua segurança.

Instalação prévia

O aparelho está concebido para instalação em armários de cozinha disponíveis comercialmente. Deve ser deixada uma distância de segurança entre o equipamento e as paredes e móveis. Ver figura (valores em mm).

- As superfícies, os laminados sintéticos e os adesivos utilizados devem ser resistentes ao calor (100 °C no mínimo).
- Os armários da cozinha devem estar nivelados e fixados.
- Se houver uma gaveta por debaixo do forno, deverá ser instalada uma prateleira entre o forno e a gaveta.
- O equipamento deve ser transportado, pelo menos, por duas pessoas.
- Para mover o forno, segure-o a partir dos orifícios para manuseamento existentes de ambos os lados.
- Antes de instalar o produto, remova todos materiais e documentos do seu interior.
- O móvel da cozinha deverá estar em conformidade com as dimensões dadas na imagem abaixo. Na parte traseira do móvel da cozinha, deverá ser cortada uma abertura com as dimensões dadas na imagem abaixo para assegurar uma ventilação suficiente.



Não instale o produto junto a frigoríficos ou congeladores. O calor emitido pelo produto levará a um aumento no consumo de energia dos aparelhos de refrigeração.



Não utilize a porta e/ou o manípulo para levantar ou mover o produto.

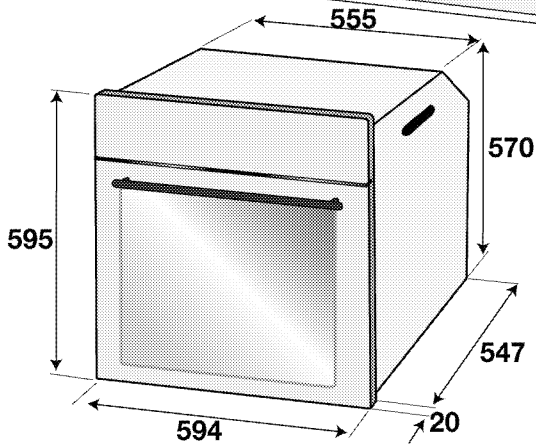
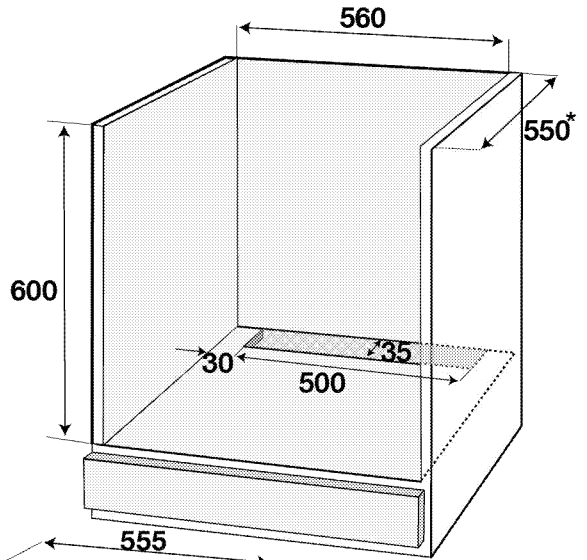
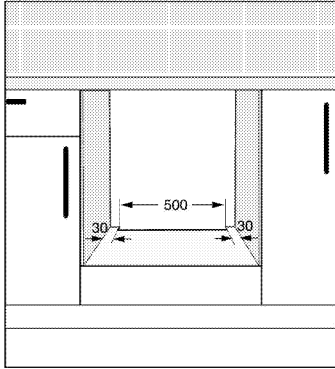
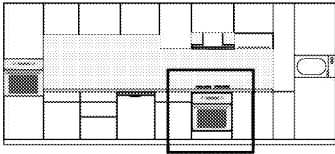

* min.

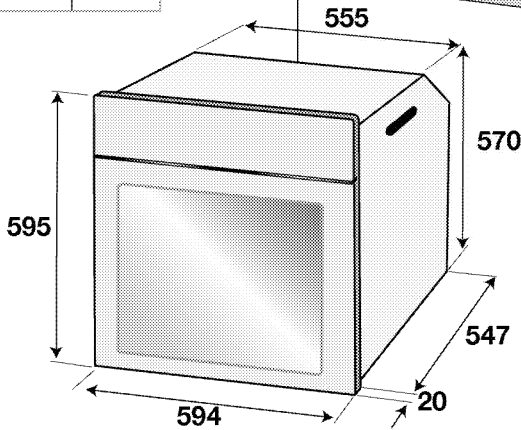
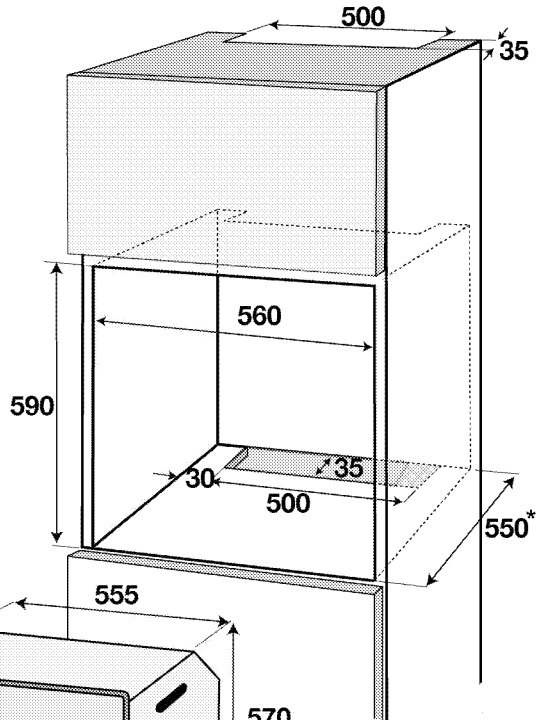
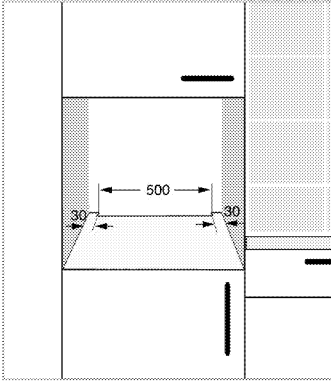
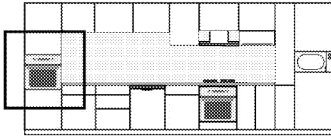

* min.

Instalação e ligação

- O produto pode apenas ser instalado e ligado de acordo com as regras de instalação estatutárias.

Ligação eléctrica

Ligue o produto a uma tomada/linha de terra, protegida por um fusível miniatura com capacidade adequada conforme o estabelecido na tabela de «Especificações técnicas». A instalação de terra deve ser realizada por um electricista qualificado, quer use o produto com ou sem um transformador. A nossa empresa não se responsabilizará por quaisquer danos

originados pelo uso do produto sem uma instalação de terra, de acordo com os regulamentos locais.



PERIGO:

O produto deve ser ligado à instalação eléctrica apenas por uma pessoa qualificada e autorizada. O período de garantia do produto inicia-se apenas após a instalação correcta. O fabricante não deve ser responsabilizado por danos oriundos de procedimentos realizados por pessoas não autorizadas.

**PERIGO:**

O cabo eléctrico não deve ser prensado, obstruído ou comprimido ou ficar em contacto com as partes quentes do produto.
Um cabo danificado deve ser substituído por um electricista qualificado. Caso contrário, há risco de choque eléctrico, curto-circuito ou incêndio!

- A ligação deve cumprir com os regulamentos nacionais.
- Os dados de fornecimento eléctrico devem corresponder aos dados especificados na placa de características do produto. Abra a porta frontal para verificar a placa de características.
- O cabo de alimentação do seu produto deve cumprir com os valores da tabela "Technical specifications" (Especificações técnicas).

**PERIGO:**

Antes de iniciar qualquer trabalho na instalação eléctrica, desligue o produto da corrente eléctrica.
Há risco de choque eléctrico!



A ficha do cabo de alimentação deve ser de fácil acesso após a instalação (não passar por cima da placa).



Aquando da realização da instalação elétrica, deve aplicar os regulamentos nacionais/locais e deve utilizar a tomada/linha adequada e ficha para o forno. No caso de os limites de potência do produto estarem fora da capacidade de corrente da ficha e tomada/linha, o produto deve ser ligado através de instalação elétrica fixa diretamente sem utilizar uma ficha e tomada/linha.

Ligue o cabo de alimentação à tomada.

Instalar o produto

1. Deslize o forno para dentro do armário, alinhe-o e prenda-o certificando-se, ao mesmo tempo, que o cabo de alimentação não está danificado e/ou comprimido.

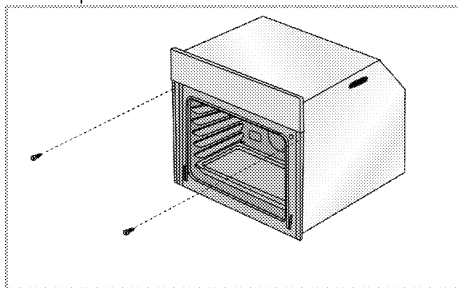

Prenda o forno com 2 parafusos como ilustrado. Após a instalação, assegure-se de que os parafusos estão suficientemente apertados e de que o forno não se move. O forno poderá inclinar-se durante a utilização caso não seja instalado segundo as instruções e caso os parafusos não estejam suficientemente apertados.

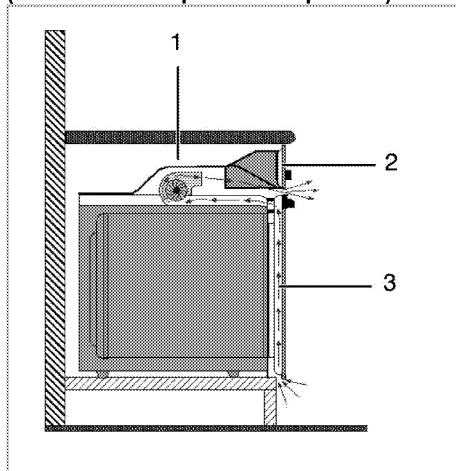
Para produtos com ventoinha de arrefecimento (Poderá não fazer parte do seu produto.)

- 1 Ventoinha de arrefecimento
- 2 Painel de controlo
- 3 Porta

A ventoinha de arrefecimento incorporada arrefece tanto o compartimento embutido como a frente do produto.



A ventoinha de arrefecimento continua a funcionar cerca de 20-30 minutos depois do forno ter sido desligado.

Se tiver cozinhado através da programação do temporizador do forno, a ventoinha de arrefecimento será também desligada do final do tempo de cozedura, juntamente com todas as funções.

Verificação final

1. Operar o produto..
2. Verifique as funções.

4 Preparações

Conselhos para poupar energia

As informações seguintes ajudá-lo(a) a utilizar o seu equipamento de uma forma ecológica e a poupar energia:

- Utilize utensílios revestidos a esmalte ou de cor escura no forno, visto que a transmissão de calor será melhor.
- Ao cozinhar as suas refeições, realize uma operação de pré-aquecimento se for aconselhável no manual do utilizador ou na descrição da cozedura.
- Durante a cozedura, não abra frequentemente a porta do forno.
- Sempre que possível, tente cozinhar mais do que um prato no forno, ao mesmo tempo. Pode cozinhar colocando dois tachos de cozedura na grelha de arame.
- Cozinhe mais algum prato após o outro. O forno ainda estará quente.
- Pode poupar energia desligando o seu forno eléctrico alguns minutos antes do fim do tempo de cozedura. Não abra a porta do forno.
- Descongele os pratos congelados antes de os cozinhar.

Uso inicial

Ajuste da hora



Ao fazer qualquer ajuste, os símbolos relacionados piscarão no visor.

Prima as teclas \oplus/\ominus para definir a hora após o forno ter sido ligado à corrente eléctrica pela primeira vez.



Para modelos de controlo digital, toque \equiv primeiro e, depois, utilize \oplus/\ominus para definir a hora do dia.

Confirme a definição tocando no símbolo ⌚ e espere 4 segundos sem tocar em qualquer tecla, para confirmar.

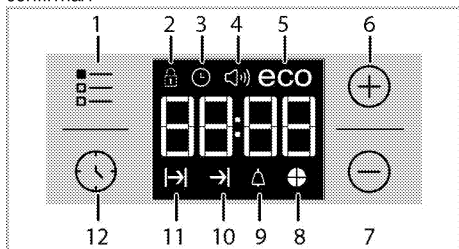

1 Tecla de ajuste

- 2 Símbolo do teclado
- 3 Símbolo do relógio
- 4 Símbolo de alarme de volume (Poderá não fazer parte do seu produto.)
- 5 Símbolo de modo ecológico
- 6 Tecla mais
- 7 Tecla menos
- 8 Símbolo da tarte do tempo
- 9 Símbolo do alarme
- 10 Símbolo do tempo de fim de cozedura
- 11 Símbolo do tempo de cozedura
- 12 Tecla do programa



Se a hora inicial não for definida, o relógio iniciará a partir das **12:00** e será exibido o símbolo ⌚ . Este símbolo desaparecerá quando a hora estiver ajustada.



As definições de hora atuais são canceladas em caso de falha de energia. Precisaráo de ser reajustadas.

Primeira limpeza da unidade



A superfície pode ficar danificada por alguns detergentes ou materiais de limpeza. Não use detergentes ou cremes/pós de limpeza agressivos ou qualquer objecto pontiagudo durante a limpeza.

1. Remova todos os materiais de embalagem.
2. Limpe as superfícies da unidade com um pano húmido ou esponja e seque com um pano.

Aquecimento inicial

Aqueça o produto por cerca de 30 minutos e depois desligue-o. Desse modo, qualquer resíduo da produção será queimado e removido.



ATENÇÃO

As superfícies quentes causam queimaduras! O produto pode aquecer quando em utilização. Nunca toque nos queimadores quentes, nas secções internas do forno, nos aquecedores, etc. Mantenha as crianças afastadas. Use sempre luvas para forno resistentes ao calor quando colocar ou retirar os pratos no/do forno quente.

Forno eléctrico

1. Retire todos os tabuleiros e a grelha de arame do forno.
2. Feche a porta do forno.

3. Seleccione a posição Estática.
4. Seleccione a potência mais alta da grelha; consulte *Como usar o forno eléctrico, página 18*.
5. Funcione o forno por cerca de 30 minutos.
6. Desligue o seu forno; consulte *Como usar o forno eléctrico, página 18*

Forno com grelhador

1. Retire todos os tabuleiros e a grelha de arame do forno.
2. Feche a porta do forno.
3. Seleccione a potência mais alta da grelha; consulte *Operar o grelhador, página 25*.
4. Funcione o forno por cerca de 30 minutos.
5. Desligue o seu grelhador; consulte *Operar o grelhador, página 25*



Poderá ocorrer maus odores e fumaça por um par de horas durante o funcionamento inicial. Isto é perfeitamente natural. Assegure que o cómodo esteja bem ventilado para extrair o fumo e o cheiro. Evite inalar directamente o fumo e os odores emitidos.

5 Funcionar com o forno

Informações gerais sobre cozer, assar e grelhar no forno



ATENÇÃO

As superfícies quentes causam queimaduras! O produto pode aquecer quando em utilização. Nunca toque nos queimadores quentes, nas secções internas do forno, nos aquecedores, etc. Mantenha as crianças afastadas. Use sempre luvas para forno resistentes ao calor quando colocar ou retirar os pratos no/do forno quente.



PERIGO:

Tenha cuidado ao abrir a porta do forno, visto que pode sair vapor. O vapor exalado pode esquentar as suas mãos, rosto e/ou olhos.

Dicas para cozer no forno

- Use placas de metal apropriadas com revestimento não aderente, vasilhas de alumínio ou formas de silicone resistentes ao calor.
- Use da melhor maneira possível o espaço na prateleira.
- Coloque a forma de assar no forno no centro da prateleira.
- Seleccione a posição correcta da prateleira antes de ligar o forno ou o grelhador. Não altere a posição da prateleira quando o forno estiver quente.
- Mantenha a porta do forno fechada.

Conselhos para assar

- Temperar o frango inteiro, o peru e grandes peças de carne com molhos tais como sumo de limão e pimenta preta antes da cozedura, melhorará os resultados da mesma.
- Demora mais 15 a 30 minutos para assar a carne com osso se comparada com a carne do mesmo tamanho sem ossos.
- Cada centímetro da espessura da carne exige aproximadamente 4-5 minutos do tempo de cozedura.
- Deixe a carne repousar no forno por cerca de 10 minutos após terminar o tempo de cozedura. O suco é melhor distribuído por todo o assado e não escorre quando a carne é cortada.
- O peixe deve ser colocado na prateleira média ou inferior, numa placa resistente ao calor.

Conselhos para grelhar

Ao grelhar carne, peixe e aves, eles ficam rapidamente com uma cor acastanhada, levemente

tostados e não ficam secos. Postas, espetadas de carne e salsichas, bem como os legumes com um elevado teor de água, tais como os tomates e as cebolas, são particularmente apropriados para serem grelhados.

- Distribua as peças a serem grelhadas na grelha de arame ou no tabuleiro de pastelaria com a grelha de arame, de tal forma que o espaço coberto não exceda o tamanho do aquecedor.
- Deslize a grelha de arame ou o tabuleiro de pastelaria para o nível pretendido no forno. Se estiver a grelhar na grelha de arame, deslize o tabuleiro de pastelaria até a prateleira inferior para recolher a gordura. Adicione alguma água no tabuleiro para uma limpeza mais fácil.



Os alimentos que não são apropriados para grelhar provocam o risco de incêndio. Grelhe apenas alimentos que sejam apropriados para o calor intenso do grelhador.

Não coloque os alimentos muito longe no fundo da grelha. Esta área é muito quente e os alimentos com gordura podem incendiar-se.

Como usar o forno eléctrico

Seleccionar a temperatura e o modo de funcionamento

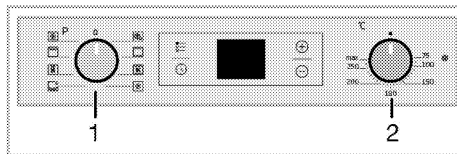

- 1 Botão da função
 - 2 Botão do termóstato
1. Defina o botão de temperatura para a temperatura pretendida.
 2. Defina o botão de função para o modo de funcionamento pretendido.
- » O forno aquece até a temperatura ajustada e mantém-se ali. Durante o aquecimento, a lâmpada da temperatura permanece acesa.

Desligar o forno eléctrico

Rode o botão da função e o botão de temperatura para a posição off (superior).

É importante colocar a grelha de arame correctamente na prateleira de arame. A grelha de arame deve ser inserida entre as prateleiras de arame, conforme ilustrado na figura.

Não deixe a grelha de arame encostada contra a parede traseira do forno. Deslize a sua grelha de arame até a secção frontal da prateleira e ajuste-a com a ajuda da porta, para obter um bom desempenho no grelhado.

(Varia dependendo do modelo do produto.)

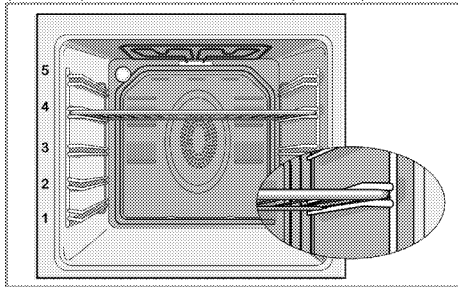

Modos de funcionamento

A ordem dos modos de funcionamento mostrada aqui pode diferir da organização no seu produto.

'Top and bottom heating' (Aquecimento superior e inferior)



Os aquecimentos superior e inferior estão em funcionamento. O alimento é aquecido simultaneamente a partir de cima e de baixo. Por exemplo, é apropriado para bolos, pastelaria ou bolos e estufados em formas de assar. 'Cook with one tray only' (Fogão com um só tabuleiro).

'Bottom heating' (Aquecimento inferior)



Apenas o aquecimento inferior está em funcionamento. É apropriado para pizza e o conseqüente alouramento dos alimentos a partir de baixo.



Esta função pode ser utilizada também para a limpeza a vapor fácil.

'Fan supported bottom/top heating' (Aquecimento inferior/superior ajudado pela ventoinha)



O aquecimento superior, inferior e mais a ventoinha (na parede posterior) estão em funcionamento. O ar quente é uniforme e rapidamente distribuído pelo forno através da ventoinha. 'Cook with one tray only' (Fogão com um só tabuleiro).

'Operating with fan' (Funcionamento com ventoinha)



O forno não está aquecido. Apenas a ventoinha (na parede posterior) está a funcionar. Apropriado para derreter alimentos granulares lentamente em temperatura ambiente e para arrefecer o alimento cozinhado.

'Fan Heating' (Aquecimento por ventoinha)



O ar quente provocado pelo aquecedor traseiro é uniformemente distribuído por todo o forno muito rapidamente, através da ventoinha.



É apropriado para cozinhar os seus alimentos em diferentes níveis da prateleira e, em muitos casos, não é necessário pré-aquecer. Apropriado para cozinhar com vários tabuleiros. Esta função pode ser utilizada também para a limpeza a vapor fácil.

'3D' function' (Função "3D")



O aquecimento superior, inferior e o aquecimento assistido pela ventoinha (na parede posterior) estão em funcionamento. O alimento é cozido uniforme e rapidamente por inteiro. 'Cook with one tray only' (Fogão com um só tabuleiro).

'Full grill' (Grelhador completo)



A grelha larga no tecto do forno está em funcionamento. É apropriado para grelhar grandes quantidades de alimento.

- Coloque porções grandes ou de médio tamanho na posição correcta da prateleira sob o aquecedor do grelhador para grelharem.
- Ajuste a temperatura para o nível máximo.
- Volte os alimentos a meio do tempo de grelhar.

'Grill+Fan' (Grelhador + ventoinha)





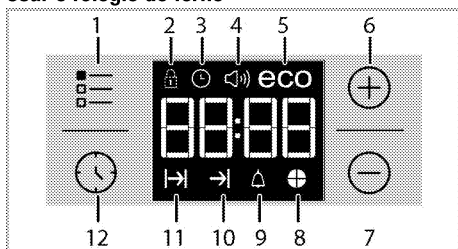

O efeito de grelhar não é tão forte como com o grelhador completo

- Coloque porções pequenas ou de médio tamanho na posição correcta da prateleira sob o aquecedor do grelhador para grelharem.
- Defina a temperatura pretendida.
- Volte os alimentos a meio do tempo de grelhar.

Usar o relógio do forno







- 1 Tecla de ajuste
- 2 Símbolo do teclado
- 3 Símbolo do relógio
- 4 Símbolo de alarme de volume (Poderá não fazer parte do seu produto.)
- 5 Símbolo de modo ecológico
- 6 Tecla mais
- 7 Tecla menos
- 8 Símbolo da tarte do tempo
- 9 Símbolo do alarme
- 10 Símbolo do tempo de fim de cozedura
- 11 Símbolo do tempo de cozedura
- 12 Tecla do programa

	O tempo máximo que pode ser definido para o final da cozedura é de 5 horas e 59 minutos. O programa será cancelado em caso de falha eléctrica. Terá que reprogramar o forno.
	Ao fazer qualquer ajuste, os símbolos relacionados piscarão no visor. Deverá esperar algum tempo para que as definições sejam aplicadas.
	Se não for feita uma definição de cozedura, a hora do dia não pode ser ajustada.
	O tempo restante será exibido, logo que seja iniciada a cozedura.













Cozinhar especificando o tempo de cozedura;

Pode ajustar o forno para que pare no final do tempo especificado, definindo o tempo de cozedura no temporizador.

1. Selecione a função de cozedura.
 2. Toque em  até que o símbolo  apareça no mostrador do tempo de cozedura.
 3. Ajustar o tempo de cozedura com as teclas  / .
- » » Uma vez definido o tempo de cozedura, o símbolo  e a fatia de tempo serão exibidos no mostrador de forma contínua.
4. Coloque os alimentos no forno e defina a temperatura com o botão de temperatura. O processo de cozedura iniciar-se-á.
- » » O tempo de cozedura começa a decrescer no mostrador quando o cozinhado se inicia e todas as partes do símbolo da fatia de tempo são acesas. O tempo de cozedura definido é dividido em 4 partes iguais e quando o tempo de cada uma delas termina, o símbolo dessa parte desliga-se. Assim, poderá ficar a saber facilmente a proporção de tempo de cozedura que ainda lhe resta.

Definir o final do tempo de cozedura para uma hora mais tardia;

Após definir o tempo de cozedura no temporizador, pode definir o final do tempo de cozedura para uma hora mais tardia.

1. Selecione a função de cozedura.
 2. Toque em  até que o símbolo  apareça no mostrador do tempo de cozedura.
 3. Ajustar o tempo de cozedura com as teclas  / .
- » » Uma vez definido o tempo de cozedura, o símbolo  será exibido no mostrador de forma contínua.
4. Toque em  até que o símbolo  apareça no mostrador do final de tempo de cozedura.
 5. Para ajustar a hora de fim de cozedura, pressione as teclas  / .
- » » Uma vez definido o tempo de cozedura, o símbolo  mais o símbolo  e serão exibidos no mostrador de forma contínua. Logo que a cozedura comece, o símbolo  desaparecerá.
6. Coloque os alimentos no forno e defina a temperatura com o botão de temperatura. O processo de cozedura iniciar-se-á.
- » » O temporizador do forno calcula automaticamente o tempo de início subtraindo o tempo de cozedura à hora de fim de cozedura que definiu. O modo de funcionamento selecionado é ativado quando começa o tempo de início da cozedura

e o forno aquece até a temperatura definida. Manterá esta temperatura até o fim do tempo da cozedura.





» O tempo de cozedura começa a decrescer no mostrador quando o cozinhado se inicia e todas as partes do símbolo da fatia de tempo são acesas. O tempo de cozedura definido é dividido em 4 partes iguais e quando o tempo de cada uma delas termina, o símbolo dessa parte desliga-se. Assim, poderá ficar a saber facilmente a proporção de tempo de cozedura que ainda lhe resta.

7. Após o processo de cozedura estar terminado, aparecerá "Fim" no visor e o sinal de alarme soará.
8. O sinal audível soará durante 2 minutos. Para parar o alarme, basta premir qualquer tecla. O alarme será silenciado e passará a ser exibida a hora atual.

 Se premir qualquer tecla no final do período do alarme, o forno recomeçará a funcionar. Rode o botão da temperatura e o botão de função para a posição "0" (desligado) para desligar o forno de forma a evitar que volte a funcionar no final do aviso.



Ativar o bloqueio das teclas

Pode evitar a utilização do forno ativando a função de bloqueio das teclas.

1. Toque em  até que o símbolo  apareça no mostrador.
- » "OFF" (Desligado) aparecerá no visor.
2. Toque na tecla  para ativar o bloqueio de teclas.
- » Uma vez ativado o bloqueio das teclas, "On" (Ligado) aparece no visor e o símbolo de  permanece aceso.

 As teclas do forno não funcionam quando a função de bloqueio das teclas está ativada. O bloqueio das teclas não será cancelado em caso de falha elétrica.

Para desativar o bloqueio de teclas



1. Toque em  até que o símbolo  apareça no mostrador.
- » "On" (Ligado) aparecerá no visor.
2. Desative o bloqueio de teclas premindo a tecla .
- » "OFF" será exibido depois de desativado o bloqueio das teclas.

Ajustar o relógio de alarme

Pode usar o temporizador do produto para qualquer aviso ou lembrete, para além do programa de cozedura.

O relógio de alarme não influencia as funções do forno. É usado apenas como aviso. Por exemplo, é útil

quando quer virar o alimento no forno num certo ponto da cozedura. O temporizador fará um sinal audível no final do tempo definido.

1. Toque em  até que o símbolo  apareça no mostrador.

 O tempo máximo do alarme pode ser de 23 horas e 59 minutos.

2. Defina a duração do alarme usando as teclas  / .

 As teclas de função para tom de alarme, hora do dia, brilho do visor e de temperatura devem estar na posição 0 (DESLIGADAS).



» O símbolo  permanecerá aceso e o tempo do alarme aparecerá no visor, uma vez definida a hora do alarme.

3. No fim do tempo do alarme, o símbolo  começará a piscar e o sinal do alarme será ouvido.

Desligar o alarme





1. O sinal audível soará durante 2 minutos. Para parar o alarme, basta premir qualquer tecla.
- » O alarme será silenciado e passará a ser exibida a hora atual.

Cancelar o alarme;

1. Toque em  até que o símbolo  apareça no mostrador, para cancelar o alarme.
2. Mantenha premida a tecla  até que apareça "00:00".

 A hora do alarme será exibida. Se a hora do alarme e o tempo de cozedura forem definidos conjuntamente, será exibido o tempo mais curto.





Alterar o tom do alarme

1. Toque em  até que o símbolo  apareça no mostrador.
2. Ajuste o tom de alarme desejado com as teclas  / .
3. O tom que definiu será ativado dentro de um curto período de tempo.

» O tom do alarme seleccionado aparecerá como "b-01", "b-02" ou "b-03 no visor.



Alterar a hora do dia

Para mudar a hora que definiu anteriormente:



1. Toque em  até que o símbolo  apareça no mostrador.
2. Defina a hora do dia com as teclas  / .
3. A hora que definiu será ativada dentro de um curto período de tempo.

Modo económico

Pode poupar energia com o modo económico ao cozinhar, definindo o tempo de cozedura no forno. Este modo completa a cozedura com a temperatura interna do forno, desligando os elementos de aquecimento antes de terminar o tempo de cozedura.

1. Toque em  até que o símbolo **eco** apareça no mostrador.
- » **"OFF" (Desligado)** aparecerá no visor.
2. Ative o modo económico tocando na tecla .
- » Uma vez ativado o bloqueio das teclas, **"On" (Ligado)** aparece no visor e o símbolo **eco** permanece aceso.

Desativar o Modo económico

1. Toque no símbolo  até que o símbolo **eco** apareça no mostrador.
- » **"On" (Ligado)** aparecerá no visor.
2. Desative o modo económico tocando na tecla .
- » **"OFF"** será exibido depois de desativado o bloqueio das teclas.

Definir o brilho do mostrador

(Esta funcionalidade é opcional. Poderá não fazer parte do seu produto.)



1. Toque  Até que **d-01** ou **d-02** ou **d-03** apareçam no mostrador para acertar o seu brilho.
 2. Defina o brilho desejado com as teclas  / .
- » O brilho que definiu será ativado dentro de um curto período de tempo.

Tabela de tempos de cozedura















Os tempos neste capítulo servem como guia. Os tempos podem variar devido a temperatura do alimento, espessura, tipo e a sua preferência de cozedura.

Cozer no forno e assar



A 1ª prateleira do forno é a **prateleira** do fundo.

Prato	Número do tabuleiro	Acessório a utilizar	Modo de funcionamento	Posição da prateleira	Temperatura (°C)	Tempo de cozedura (aprox. em min.)
Bolos no tabuleiro	Um tabuleiro	Tabuleiro padrão*		3	180	25 ... 30
Bolos na forma	Um tabuleiro	Forma para bolos na grelha de arame**		2	180	40 ... 50
Bolos pequenos	Um tabuleiro	Tabuleiro padrão*		3	160	25 ... 35
	Um tabuleiro	Tabuleiro padrão*		3	150	30 ... 40
	2 tabuleiros	1-Tabuleiro para doces* 3-Tabuleiro padrão*		1 - 3	150	35 ... 50
	3 tabuleiros	1-Tabuleiro padrão* 3-Tabuleiro para doces* 5-Tabuleiro fundo*		1 - 3 - 5	150	35 ... 50
Bolo fofa	Um tabuleiro	Forma de mola redonda com 26 cm de diâmetro na grelha de arame**		3	160	25 ... 35
	Um tabuleiro	Forma de mola redonda com 26 cm de diâmetro na grelha de arame**		2	150	30 ... 40
	2 tabuleiros	1-Forma de mola redonda com 26 cm de diâmetro na grelha de arame** 4-Forma de mola redonda com 26 cm de diâmetro no tabuleiro para doces**		1 - 4	150	35 ... 45
Bolinhos	Um tabuleiro	Tabuleiro para doces*		3	180	25 ... 30
	2 tabuleiros	1-Tabuleiro para doces* 3-Tabuleiro padrão*		1 - 3	180	30 ... 40
	3 tabuleiros	1-Tabuleiro para		1 - 3 - 5	180	35 ... 45

		doces* 3-Tabuleiro padrão* 5-Tabuleiro fundo*				
Massa de pão	Um tabuleiro	Tabuleiro padrão*		2	200	30 ... 40
	2 tabuleiros	1-Tabuleiro para doces* 5-Tabuleiro padrão*		1 - 5	200	45 ... 55
	3 tabuleiros	1-Tabuleiro para doces* 3-Tabuleiro padrão* 5-Tabuleiro fundo*		1 - 3 - 5	200	55 ... 65
Pastelaria fina	Um tabuleiro	Tabuleiro padrão*		2	200	25 ... 35
	2 tabuleiros	1-Tabuleiro para doces* 3-Tabuleiro padrão*		1 - 3	200	35 ... 45
	3 tabuleiros	1-Tabuleiro para doces* 3-Tabuleiro padrão* 5-Tabuleiro fundo*		1 - 3 - 5	190	45 ... 55
Massa com fermento	Um tabuleiro	Tabuleiro padrão*		2	200	35 ... 45
Lasanha	Um tabuleiro	Panela retangular de vidro/metálica na grelha de arame**		2 - 3	200	30 ... 40
Pizza	Um tabuleiro	Tabuleiro padrão*		2	200 ... 220	15 ... 20
Bife (inteiro) /Rosbife	Um tabuleiro	Tabuleiro padrão*		3	25 min. 250/max, depois 180 ... 190	100 ... 120
Perna de borrego (guisada)	Um tabuleiro	Tabuleiro padrão*		3	25 min. 250/max, depois 190	70 ... 90
	Um tabuleiro	Tabuleiro padrão*		3	25 min. 250/max, depois 190	60 ... 80
Frango assado (1,8-2 kg)	Um tabuleiro	Tabuleiro padrão*		2	15 min. 250/max, depois 180 ... 190	60 ... 80
	Um tabuleiro	Tabuleiro padrão*		2	15 min. 250/max, depois 180 ... 190	60 ... 80
Perú (5.5 kg)	Um tabuleiro	Tabuleiro padrão*		1	25 min. 250/max, depois 180 ... 190	150 ... 210
	Um tabuleiro	Tabuleiro padrão*		1	25 min. 250/max, depois 180 ... 190	150 ... 210
Peixe	Um tabuleiro	Tabuleiro padrão*		3	200	20 ... 30
	Um tabuleiro	Tabuleiro padrão*		3	200	20 ... 30

Sugere-se que efectue o pré-aquecimento para todos os alimentos.

* Estes acessórios poderão não ser fornecidos com o produto.













** Estes acessórios não são fornecidos com o produto. São acessórios que estão disponíveis comercialmente.

Bancada para refeições de teste

As refeições são preparadas nesta bancada em conformidade com a EN 60350-1 para que os

institutos responsáveis pelo controlo possam testar o produto com uma maior facilidade

Prato	Número do tabuleiro	Acessório a utilizar	Modo de funcionamento	Posição da prateleira	Temperatura (°C)	Tempo de cozedura (aprox. em min.)
Bolo seco friável	Um tabuleiro	Tabuleiro padrão*		3	140	20 ... 30

	Um tabuleiro	Tabuleiro padrão*		3	140	20 ... 30
	2 tabuleiros	1-Tabuleiro padrão* 3-Tabuleiro para doces*		1 - 3	140	20 ... 30
	3 tabuleiros	1-Tabuleiro padrão* 3-Tabuleiro para doces* 5-Tabuleiro fundo*		1 - 3 - 5	140	25 ... 35
Bolos pequenos	Um tabuleiro	Tabuleiro padrão*		3	160	25 ... 35
	Um tabuleiro	Tabuleiro padrão*		3	150	30 ... 40
	2 tabuleiros	1-Tabuleiro para doces* 3-Tabuleiro padrão*		1 - 3	150	35 ... 50
	3 tabuleiros	1-Tabuleiro padrão* 3-Tabuleiro para doces* 5-Tabuleiro fundo*		1 - 3 - 5	150	35 ... 50
Bolo fofo	Um tabuleiro	Forma de mola redonda com 26 cm de diâmetro na grelha de arame**		3	160	25 ... 35
	Um tabuleiro	Forma de mola redonda com 26 cm de diâmetro na grelha de arame**		2	150	30 ... 40
	2 tabuleiros	1-Forma de mola redonda com 26 cm de diâmetro na grelha de arame** 4-Forma de mola redonda com 26 cm de diâmetro no tabuleiro para doces**		1 - 4	150	35 ... 45
Tarte de maçã	Um tabuleiro	Prato metálico preto redondo com 20 cm de diâmetro na grelha de arame**		2	180	50 ... 60
	Um tabuleiro	Prato metálico preto redondo com 20 cm de diâmetro na grelha de arame**		2	170	50 ... 60
	2 tabuleiros	1-Prato metálico preto redondo com 20 cm de diâmetro na grelha de arame** 4-Prato metálico		1 - 4	170	50 ... 60

preto redondo com 20 cm de diâmetro no tabuleiro para doces**

Sugere-se que efectue o pré-aquecimento para todos os alimentos.

* Estes acessórios poderão não ser fornecidos com o produto.

** Estes acessórios não são fornecidos com o produto. São acessórios que estão disponíveis comercialmente.

Conselhos para cozer bolos

- Se o bolo for demasiado seco, aumente a temperatura em cerca 10 e reduza o tempo de cozedura.
- Se o bolo for húmido, use menos líquido ou diminua a temperatura em 10°C.
- Se o bolo estiver escuro em cima, coloque-a na prateleira inferior, baixe a temperatura e aumente o tempo de cozedura.
- Se bem cozido no interior, mas mole no exterior, use menos líquido, diminua a temperatura e aumente o tempo de cozedura.

Conselhos para cozer massa de pastelaria

- Se o pastel for demasiado seco, aumente a temperatura em cerca 10 e reduza o tempo de cozedura. Humedeça as camadas da massa com um molho composto de leite, óleo, ovo e iogurte.
- Se o pastel demorar muito a assar, preste atenção se a espessura do pastel que preparou não excede a profundidade do tabuleiro.
- Se a parte superior do pastel estiver castanha, mas a parte inferior não estiver cozida, verifique se a quantidade de molho que usou para o pastel não está muito concentrada no fundo do mesmo. Tente espalhar o molho de forma igual entre as camadas da massa e no topo do pastel para um acastanhado uniforme.

 Cozinhe o pastel de acordo com o modo e temperatura dados na tabela de cozedura. Se a parte do fundo continuar a não ficar acastanhada o suficiente, coloque-a numa prateleira mais baixa da próxima vez.

Tabelas de tempos de cozedura para grelhar Grelhar com grelhador eléctrico

Alimento	Acessório a utilizar	Posição da prateleira	Temperatura recomendada (°C)**	Tempo de grelhar (aprox.)
Peixe	Grelha de arame	4..5	250/max	20...25 min. #
Frango fatiado	Grelha de arame	4..5	250/max	25...35 min.
Costeletas de borrego	Grelha de arame	4..5	250/max	20...25 min.
Rosbife	Grelha de arame	4..5	250/max	25...30 min. #
Costeletas de vitela	Grelha de arame	4..5	250/max	25...30 min. #
Torrada *	Grelha de arame	4	250/max	1...3 min.

dependendo da espessura

*Pré-aquecer durante 5 minutos

**Se a temperatura de grelhador do seu produto não puder ser ajustada, o grelhador irá funcionar na temperatura máxima.

Conselhos para cozinhar legumes

- Se os pratos de legumes liberarem demasiado sumo e ficarem muito secos, cozinhe-os num tacho com tampa, ao invés de tabuleiro. Os tachos fechados preservarão o sumo do prato.
- Se um prato de legumes não ficar cozido, coza antecipadamente os legumes ou prepare-os como alimentos enlatados e coloque-os no forno.

Operar o grelhador



ATENÇÃO

Feche a porta do forno ao grelhar. As superfícies quentes podem causar queimaduras!

Ligar o grelhador

1. Rode o botão de função até o símbolo de grelhador pretendido.
2. Depois, seleccione uma temperatura do grelhador desejada.
3. Se necessário, realize um pré-aquecimento de cerca de 5 minutos.

» A luz da temperatura acende-se.

Desligar o grelhador

1. Rode o botão da função para a posição Off (topo).



Os alimentos que não são apropriados para grelhar provocam o risco de incêndio. Grelhe apenas alimentos que sejam apropriados para o calor intenso do grelhador.

Não coloque os alimentos muito longe no fundo da grelha. Esta área é muito quente e os alimentos com gordura podem incendiar-se.

As refeições são preparadas nesta bancada em conformidade com a EN 60350-1 para que os

institutos responsáveis pelo controlo possam testar o produto com uma maior facilidade

Alimento	Acessório a utilizar	Posição da prateleira	Temperatura (°C)	Tempo de cozedura (aprox. em min.)
Torrada	Grelha de arame	4	250/max	1...3 min.
Almôndegas (carne de vaca) - 12 em pedaços	Grelha de arame	4	250/max	25...35 min.

Vire os alimentos passado 2/3 do tempo total de preparação.
Sugere-se que efetue o pré-aquecimento de 5-6 minutos para todos os alimentos grelhados.

6 Manutenção e cuidados

Informações gerais

A vida útil do produto será estendida e os problemas frequentes diminuirão se o produto for limpo em intervalos regulares.



PERIGO:

Desligue o produto da corrente eléctrica antes de iniciar as tarefas de limpeza e manutenção. Há risco de choque eléctrico!



PERIGO:

Deixe que o produto arrefeça antes de o limpar. As superfícies quentes podem causar queimaduras!

- Limpe totalmente o produto a cada utilização. Desta forma, será possível remover mais facilmente os resíduos da cozedura, evitando assim que estes se queimem da próxima vez que o equipamento for utilizado.
- Não é necessário qualquer agente especial de limpeza para limpar o produto. Para limpar o produto, use água morna com líquido de limpeza, um pano ou esponja macia e seque-o com um pano seco.
- Após a limpeza, verifique sempre se qualquer excesso de líquido foi completamente limpo e remova imediatamente qualquer derrame.
- Não use agentes de limpeza que contêm ácido ou cloro para limpar as superfícies de inox e a pega de aço inoxidável. Use um pano macio com líquido detergente (não abrasivo) para limpar estas partes e procure passar o pano apenas numa direcção.



A superfície pode ficar danificada por alguns detergentes ou materiais de limpeza. Não use detergentes ou cremes/pós de limpeza agressivos ou qualquer objecto pontiagudo durante a limpeza.



Não use limpadores a vapor para limpar o aparelho, já que podem provocar um choque eléctrico.

Limpar o painel de controlo

Limpe o painel e os botões de controlo com um pano húmido e seque-os.



Se o seu produto estiver equipado com botões/teclas, não remova as teclas de controlo para limpar o painel de controlo. O painel de controlo pode ficar danificado!

Limpar o forno

Para limpar a parede lateral (Varia dependendo do modelo do produto.)

(Esta funcionalidade é opcional. Poderá não fazer parte do seu produto.)

1. Retire a parte frontal da prateleira lateral, puxando-a na direcção contrária à da parede lateral.
2. Retire completamente a prateleira lateral, puxando-a para si.

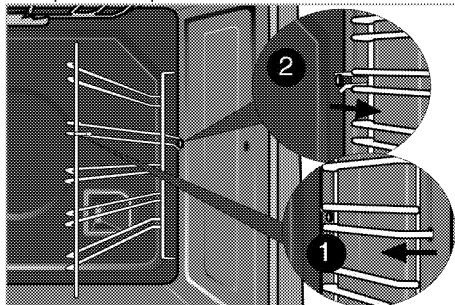

Paredes catalíticas

(Esta funcionalidade é opcional. Poderá não fazer parte do seu produto.)

As paredes laterais interiores (A) e/ou a parede traseira (B) do seu produto poderão estar revestidas de esmalte catalítico. As paredes catalíticas apresentam uma cor mate clara e uma superfície porosa. As paredes catalíticas do forno não devem ser limpas. As superfícies porosas das paredes catalíticas limpam-se automaticamente ao absorver e converter os salpicos de óleo (vapor e dióxido de carbono).

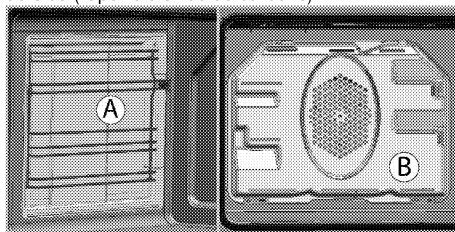

Limpeza a vapor fácil

Assegura a limpeza fácil porque a sujidade (recente ou incrustada) é amaciada com o vapor que se forma dentro do forno e a água que cai pela condensação nas superfícies internas do forno.

1. Remova todos os acessórios de dentro do forno.
2. Verta 500 ml de água para o tabuleiro do forno e coloque-o na 2ª prateleira do forno.

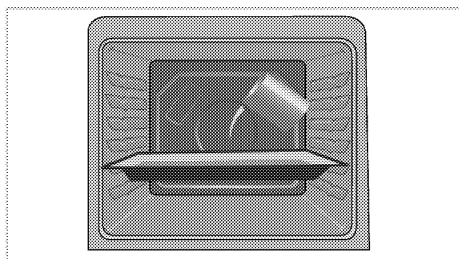

3. Ajuste o forno para o modo de limpeza a vapor fácil e executar a 100 ° C por 25 minutos.
4. Abra a porta e limpe a superfície interna do forno com uma esponja ou pano húmido.
5. Para limpar a sujidade persistente, use água morna com líquido de limpeza, um pano ou esponja macia e seque-o com um pano seco.



Durante o modo de limpeza fácil a vapor, a água que se encontra no tabuleiro para amolecer ligeiramente os resíduos/sujidade existentes na cavidade do forno evapora e condensa na cavidade e no vidro interior da porta do forno. Consequentemente, é possível que escorra água ao abrir a porta do forno. Limpe os vestígios de condensação assim que a porta do forno for aberta.

Limpar a porta do forno

Para limpar a porta do forno, use água morna com líquido de limpeza, um pano ou esponja macia e seque-o com um pano seco.



Não use limpadores ásperos abrasivos ou raspadores metálicos pontiagudos para limpar a porta do forno. Eles podem riscar a superfície e destruir o vidro.

Remover a porta do forno

1. Abra a porta frontal (1).
2. Abra os grampos do compartimento da dobradiça (2) dos lados esquerdo e direito da porta frontal, pressionando-os para baixo, conforme ilustrado na figura.

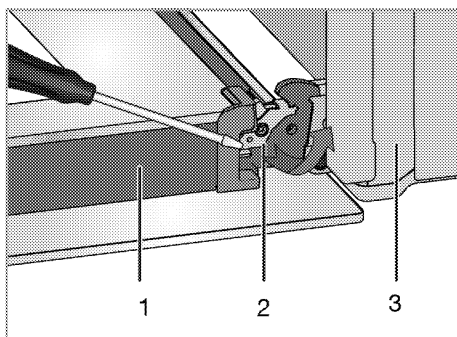

- 1 Porta
- 2 Bloqueio da dobradiça (posição fechada)
- 3 Forno
- 4 Bloqueio da dobradiça (posição aberta)

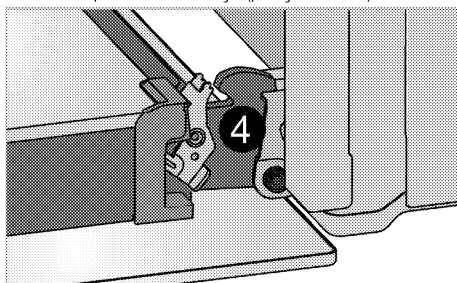

3. Desloque a porta frontal até ao meio.

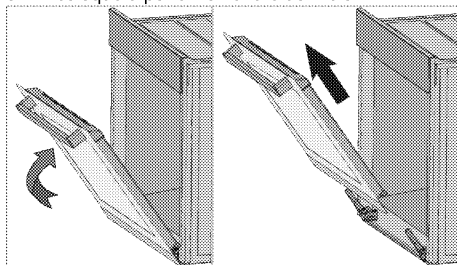

4. Remova a porta frontal puxando-a para cima para a soltar das dobradiças esquerda e direita.



Os passos executados durante o processo de remoção devem ser realizados em ordem inversa para instalar a porta. Não se esqueça de fechar os grampos no compartimento da dobradiça ao reinstalar a porta.

Remover o vidro interno da porta (Esta funcionalidade é opcional. Poderá não fazer parte do seu produto.)

O painel de vidro interno da porta do forno pode ser removido para limpeza. Abra a porta do forno.

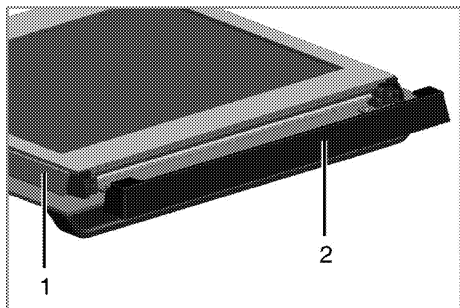

- 1 Moldura
- 2 Parte de plástico

Empurre para si e remova parte plástica instalada na secção superior da porta frontal..

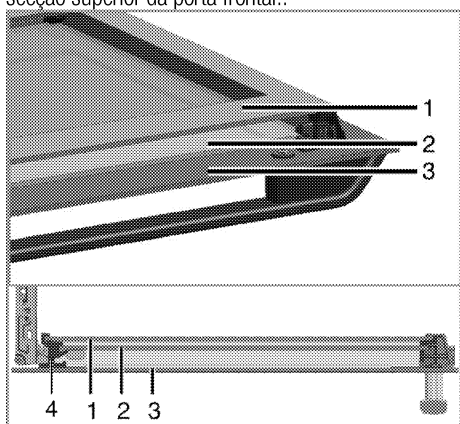

- 1 Painel de vidro mais interno
- 2 Painel de vidro interno
- 3 Painel de vidro mais externo
- 4 Ranhura plástica do painel de vidro -inferior

Como ilustrado na figura, levante ligeiramente o painel de vidro (1) mais interno na direcção A e empurre-o na direcção B.

Repita o mesmo procedimento para remover o painel de vidro interno (2).

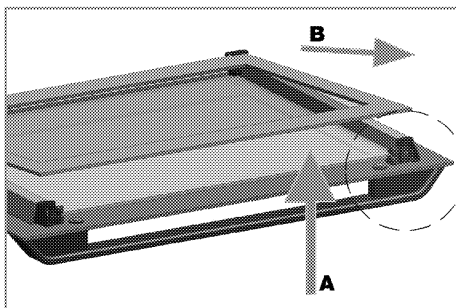

O primeiro passo para a recolocação da porta é reinstalar o painel de vidro interno (2). Como ilustrado na figura, coloque o canto chanfrado do painel de vidro para que ele se encaixe no canto chanfrado da ranhura plástica.

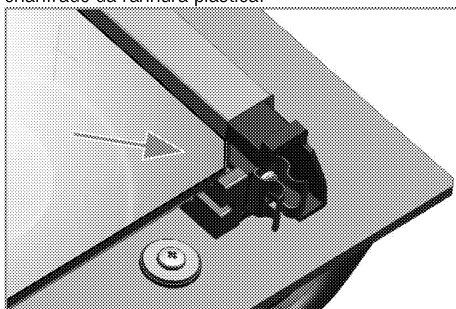

O painel de vidro interno (2) deve ser instalado na ranhura plástica próxima ao painel de vidro mais interno (1).

Ao instalar o painel de vidro mais interno (1), certifique-se que a parte pintada do painel fica voltado para o painel de vidro interno.

É importante assentar o canto inferior do painel de vidro interno dentro da ranhura de plástico inferior (5). Empurre a parte de plástico contra a estrutura até ouvir o ruído de um "clique".





Substituir a lâmpada do forno



PERIGO:

Antes de substituir a lâmpada do forno, certifique-se que o produto está desligado da tomada e arrefecido, de forma a evitar o risco de um choque eléctrico.

As superfícies quentes podem causar queimaduras!

	A lâmpada do forno possui um bulbo especial que pode resistir até 300°C. Consulte <i>Especificações técnicas, página 11</i> para detalhes. As lâmpadas do forno podem ser obtidas nos agentes de assistência autorizada.
	A posição da lâmpada pode variar daquela da figura.
	A lâmpada usada neste aparelho não é adequada para iluminação doméstica. O objetivo definido para esta lâmpada é o de ajudar o utilizador a ver os alimentos.
	As lâmpadas usadas neste aparelho têm de suportar condições físicas extremas como sejam temperaturas acima de 50°C.

Se o seu forno estiver equipado com uma lâmpada redonda:

1. Desligue o produto da corrente.
2. Rode a tampa de vidro no sentido horário, para a remover.

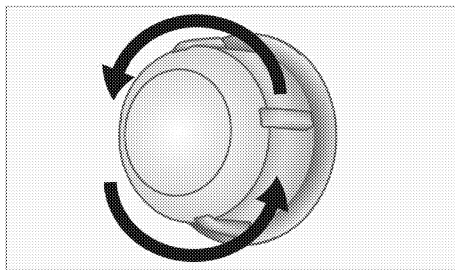

3. Se a sua lâmpada do forno for do tipo (A), apresentado na figura abaixo, retire-a, rodando conforme demonstrado, e substitua-a. Se esta for do tipo (B), puxe e retire-a, conforme apresentado na figura, e substitua-a.

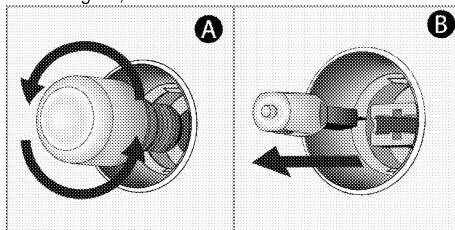

4. Instale a tampa de vidro.

7 Resolução de problemas

O forno emite vapor quando em utilização.

- É normal que se liberte vapor durante o funcionamento. >>> *Isso não é uma avaria.*

O produto provoca um ruído metálico ao aquecer e arrefecer.

- Quando as partes metálicas são aquecidas, podem se expandir e causar ruído. >>> *Isso não é uma avaria.*

O produto não funciona.

- O fusível principal está queimado ou com defeito. >>> *Verifique os fusíveis na caixa de fusíveis. Se necessário, substitua-os ou recolque-os.*
- O produto não está ligado na tomada (de terra). >>> *Verifique a ligação da ficha.*

A luz do forno não funciona.

- A lâmpada do forno está fundida. >>> *Substitua a lâmpada do forno.*
- A alimentação está cortada. >>> *Verifique se há energia. Verifique os fusíveis na caixa de fusíveis. Se necessário, substitua-os ou recolque os fusíveis.*

O forno não aquece.

- Pode não estar definido para uma função de cozedura e/ou temperatura específicas. >>> *Defina o forno para uma função e/ou temperatura específicas.*
- Nos modelos dotados de temporizador, o mesmo não está ajustado. >>> *Ajuste o tempo.* (Nos produtos com forno de microondas, o temporizador controla apenas o forno de microondas.)
- A alimentação está cortada. >>> *Verifique se há energia. Verifique os fusíveis na caixa de fusíveis. Se necessário, substitua-os ou recolque os fusíveis.*

(Em modelos com temporizador) O visor do relógio está a piscar ou o símbolo do relógio está aceso.

- Anteriormente, ocorreu alguma falha eléctrica. >>> *Ajuste a hora/ Desligue e ligue novamente o produto.*



Consulte o agente da assistência técnica autorizada ou o revendedor onde adquiriu o produto se não puder resolver os problemas, embora tenha seguido as instruções desta secção. Nunca tente reparar um produto defeituoso por conta própria.

