



Built-in Oven

User Manual

Ugradbena pećnica

Uputstvo za upotrebu

Sisseehitatav ahi

Kasutusjuhend

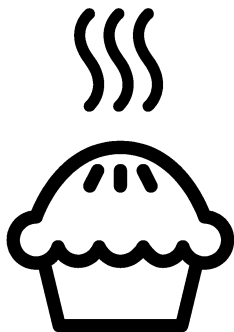

BIE24300W

EN / BS / ET

285.4486.21/R.AB/25.11.2019/4-1

7790588309

Please read this user manual first!

Dear Customer,

Thank you for purchasing this Beko product. We hope that you get the best results from your product which has been manufactured with high quality and state-of-the-art technology. Therefore, please read this entire user manual and all other accompanying documents carefully before using the product and keep it as a reference for future use. If you handover the product to someone else, give the user manual as well. Follow all warnings and information in the user manual.

Remember that this user manual is also applicable for several other models. Differences between models will be identified in the manual.

Explanation of symbols

Throughout this user manual the following symbols are used:

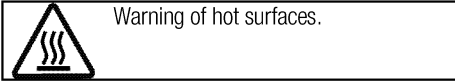
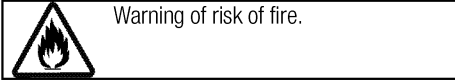
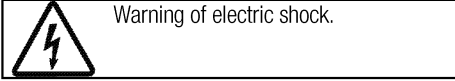
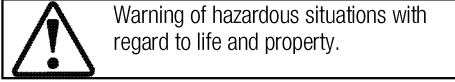
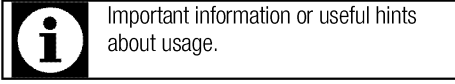

Arçelik A.Ş.
Karaağaç caddesi No:2-6
34445 Sütlüce/Istanbul/TURKEY
Made in TURKEY



This product was manufactured using the latest technology in environmentally friendly conditions.

TABLE OF CONTENTS

1 Important instructions and warnings for safety and environment 4

General safety	4
Electrical safety	4
Product safety	5
Intended use	7
Safety for children.....	7
Disposing of the old product.....	8
Package information	8

2 General information 9

Overview	9
Package contents	10
Technical specifications	11

3 Installation 12

Before installation	12
Installation and connection	14
Future Transportation.....	16

4 Preparation 17

Tips for saving energy	17
------------------------------	----

Initial use.....	17
Time setting.....	17
First cleaning of the appliance.....	17
Initial heating	17

5 How to operate the oven 19

General information on baking, roasting and grilling.....	19
How to operate the electric oven	19
Operating modes.....	20
Using the oven clock	20
Cooking times table.....	23
How to operate the grill.....	24
Cooking times table for grilling.....	24

6 Maintenance and care 25

General information.....	25
Cleaning the control panel	25
Cleaning the oven	25
Removing the oven door	26
Removing the door inner glass.....	26
Replacing the oven lamp.....	27

7 Troubleshooting 28

1 Important instructions and warnings for safety and environment

This section contains safety instructions that will help protect from risk of personal injury or property damage. Failure to follow these instructions shall void any warranty.

General safety

- This appliance can be used by children aged from 8 years and above and persons with reduced physical, sensory or mental capabilities or lack of experience and knowledge if they have been given supervision or instruction concerning use of the appliance in a safe way and understand the hazards involved.

Children shall not play with the appliance. Cleaning and user maintenance shall not be made by children without supervision.

- The appliance is not to be used by persons (including children) with reduced physical, sensory or mental capabilities, or lack of experience and knowledge, unless they have been given supervision or instruction. Children should be supervised and ensure they do not play with the appliance
- If the product is handed over to someone else for personal use or second-hand use purposes, the

user manual, product labels and other relevant documents and parts should be also given.

- Installation and repair procedures must always be performed by Authorised Service Agents. The manufacturer shall not be held responsible for damages arising from procedures carried out by unauthorised persons which may also void the warranty. Before installation, read the instructions carefully.
- Do not operate the product if it is defective or has any visible damage.
- Ensure that the product function knobs are switched off after every use.

Electrical safety

- If the product has a failure, it should not be operated unless it is repaired by an Authorised Service Agent. There is the risk of electric shock!
- Only connect the product to a grounded outlet/line with the voltage and protection as specified in the "Technical specifications". Have the grounding installation made by a qualified electrician while using the product with or without a

transformer. Our company shall not be liable for any problems arising due to the product not being earthed in accordance with the local regulations.

- Never wash the product by spreading or pouring water onto it! There is the risk of electric shock!
- The product must be disconnected during installation, maintenance, cleaning and repairing procedures.
- If the power connection cable for the product is damaged, it must be replaced by the manufacturer, its service agent or similarly qualified persons in order to avoid a hazard.
- The appliance must be installed so that it can be completely disconnected from the mains supply. The separation must be provided by a switch built into the fixed electrical installation, according to construction regulations.
- Rear surface of the oven gets hot when it is in use. Make sure that the electrical connection does not contact the rear surface; otherwise, connections can get damaged.
- Do not trap the mains cable between the oven door and frame and do not route it over hot surfaces. Otherwise, cable

insulation may melt and cause fire as a result of short circuit.

- Any work on electrical equipment and systems should only be carried out by authorised and qualified persons.
- In case of any damage, switch off the product and disconnect it from the mains. To do this, turn off the fuse at home.
- Make sure that fuse rating is compatible with the product.

Product safety

- **WARNING:** The appliance and its accessible parts become hot during use. Care should be taken to avoid touching heating elements. Children less than 8 years of age shall be kept away unless continuously supervised.
- Never use the product when your judgment or coordination is impaired by the use of alcohol and/or drugs.
- Be careful when using alcoholic drinks in your dishes. Alcohol evaporates at high temperatures and may cause fire since it can ignite when it comes into contact with hot surfaces.
- **Food Poisoning Hazard:** Do not let food sit in oven for more than 1 hour before or after cooking. Doing so can result in food poisoning or sickness.

- Do not place any flammable materials close to the product as the sides may become hot during use.
- During use the appliances becomes hot. Care should be taken to avoid touching heating elements inside the oven.
- Keep all ventilation slots clear of obstructions.
- Do not heat closed tins and glass jars in the oven. The pressure that would build-up in the tin/jar may cause it to burst.
- Do not place baking trays, dishes or aluminium foil directly onto the bottom of the oven. The heat accumulation might damage the bottom of the oven.
- Do not use harsh abrasive cleaners or sharp metal scrapers to clean the oven door glass since they can scratch the surface, which may result in shattering of the glass.
- Do not use steam cleaners to clean the appliance as this may cause an electric shock.
- (Varies depending on the product model.)

Placing the wire shelf and tray onto the wire racks properly
 It is important to place the wire shelf and/or tray onto the rack properly. Slide the wire shelf or tray between 2 rails and make

sure that it is balanced before placing food on it (Please see the following figure).

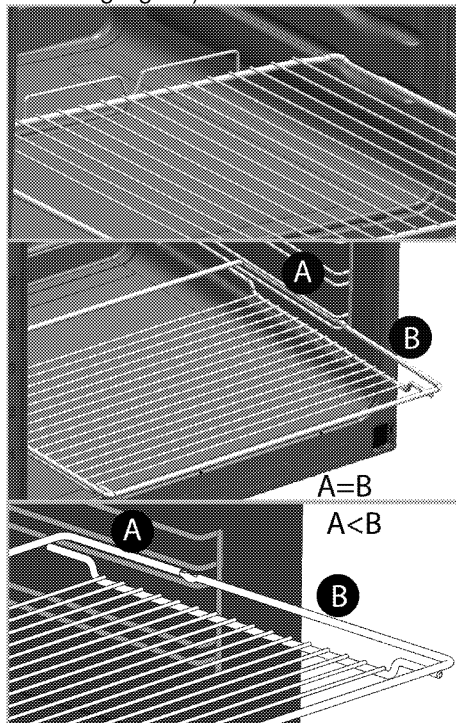

- Do not use the product if the front door glass removed or cracked.
- Always use heat resistant oven gloves when putting in or removing dishes into/from the hot oven.
- Place the baking paper into the cooking pot or on to the oven accessory (tray, wire grill etc) together with the food and then insert all into the preheated oven. Remove the excess parts of the baking paper overflowing from the accessory or the pot in order to prevent the risk of touching the

oven's heating elements. Never use the baking paper in an operating temperature higher than the indicated value for the baking paper. Do not place the baking paper directly on the base of the oven.

- **WARNING:** Ensure that power cord of the appliance is unplugged or circuit breaker is switched off before replacing the lamp to avoid the possibility of electric shock.
- The appliance must not be installed behind a decorative door in order to avoid overheating.

Prevention against possible fire risk!

- Ensure all electrical connections are secure and tight to prevent risk of arcing.
- Do not use damaged cables or extension cables.
- Ensure liquid or moisture is not accessible to the electrical connection point.

Intended use

- This product is designed for domestic use. Commercial use will void the guarantee.
- **CAUTION:** This appliance is for cooking purposes only. It must not be used for other purposes, for example room heating.
- This product should not be used for warming the plates under the grill, drying towels, dish cloths etc.

by hanging them on the oven door handles. This product should also not be used for room heating purposes.

- The manufacturer shall not be liable for any damage caused by improper use or handling errors.
- The oven can be used for defrosting, baking, roasting and grilling food.

Safety for children

- **WARNING:** Accessible parts may become hot during use. Young children should be kept away.
- The packaging materials will be dangerous for children. Keep the packaging materials away from children. Please dispose of all parts of the packaging according to environmental standards.
- Electrical products are dangerous to children. Keep children away from the product when it is operating and do not allow them to play with the product.
- Do not place any items above the appliance that children may reach for.
- When the door is open, do not load any heavy object on it and do not allow children to sit on it. It may overturn or door hinges may get damaged.

Disposing of the old product

Compliance with the WEEE Directive and Disposing of the Waste Product:



This product complies with EU WEEE Directive (2012/19/EU). This product bears a classification symbol for waste electrical and electronic equipment (WEEE).

This product has been manufactured with high quality parts and materials which can be reused and are suitable for recycling. Do not dispose of the waste product with normal domestic and other wastes at the end of its service life. Take it to the collection center for the recycling of electrical and electronic equipment.

Please consult your local authorities to learn about these collection centers.

Compliance with RoHS Directive:

The product you have purchased complies with EU RoHS Directive (2011/65/EU). It does not contain harmful and prohibited materials specified in the Directive.

Package information

- Packaging materials of the product are manufactured from recyclable materials in accordance with our National Environment Regulations. Do not dispose of the packaging materials together with the domestic or other wastes. Take them to the packaging material collection points designated by the local authorities.

2 General information

Overview

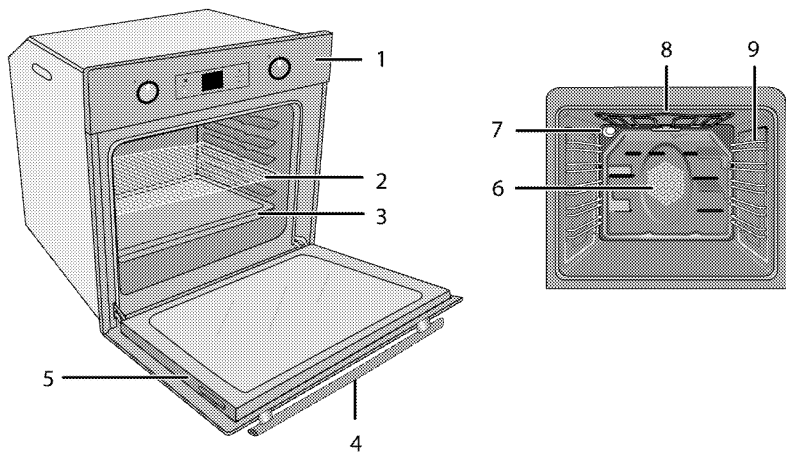

- 1 Control panel
- 2 Wire shelf
- 3 Tray
- 4 Handle
- 5 Door

- 6 Fan motor (behind steel plate)
- 7 Lamp
- 8 Top heating element
- 9 Shelf positions

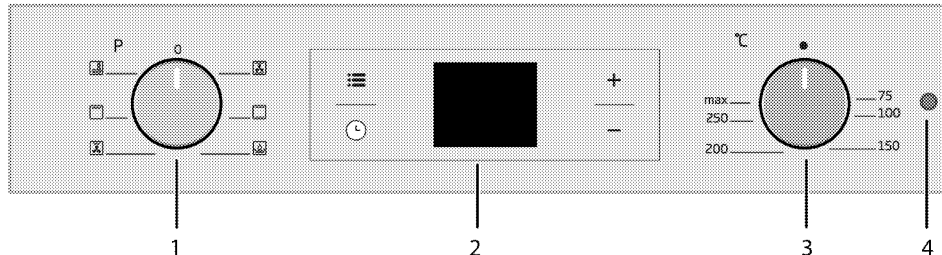

- 1 Function knob
- 2 Digital timer
- 3 Thermostat knob
- 4 Thermostat lamp

Package contents



Accessories supplied can vary depending on the product model. Not every accessory described in the user manual may exist on your product.

1. **User manual**

2. **Standard tray**

Used for pastries, frozen foods and big roasts.

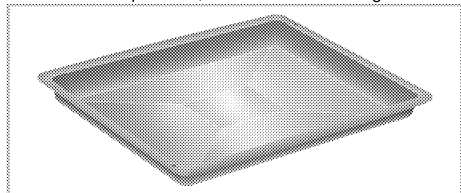

3. **Deep tray**

Used for pastries, large roasts, juicy dishes, and for collecting the fat while grilling.

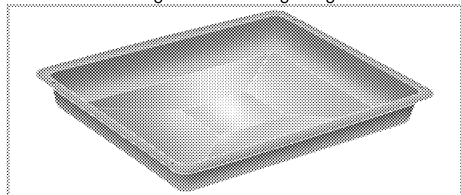

4. **Wire grill**

Used for roasting and for placing the food to be baked, roasted or cooked in casserole dishes to the desired rack.

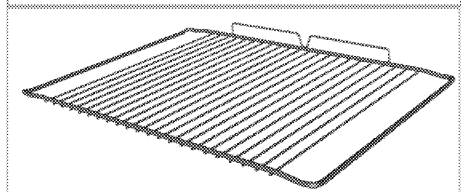
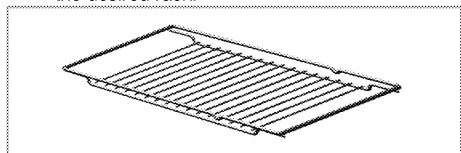

5. **Placing the wire shelf and tray onto the telescopic racks properly**
(This feature is optional. It may not exist on your product.)

Telescopic racks allow you to install and remove the trays and wire shelf easily.

When using the tray and wire shelf with telescopic racks, make sure that the pins at the rear section of the telescopic rack stands against the edges of the wire shelf and tray.

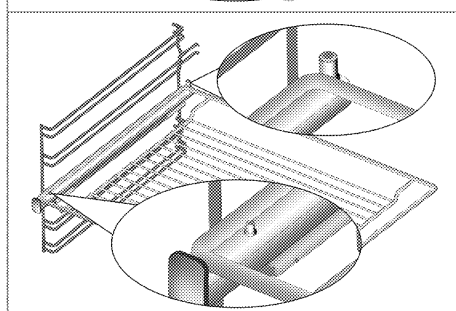
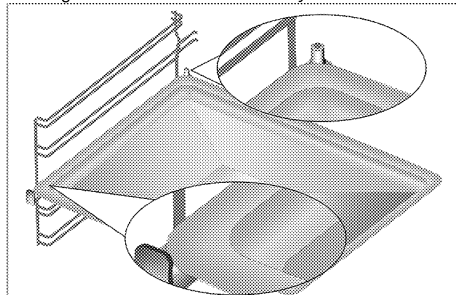

Technical specifications

Voltage / frequency	220-240 V ~ 50 Hz
Total power consumption	2.4 kW
Cable type / section	min.H05W-FG 3 x 1,5 mm ²
External dimensions (height / width / depth)	595 mm/594 mm/567 mm
Installation dimensions (height / width / depth)	**590 or 600 mm/560 mm/min. 550 mm
Main oven	Multifunction oven
Inner lamp	15/25 W
Grill power consumption	2.2 kW

Basics: Information on the energy label of electrical ovens is given in accordance with the EN 60350-1 / IEC 60350-1 standard. Those values are determined under standard load with bottom-top heater or fan assisted heating (if any) functions.

Energy efficiency class is determined in accordance with the following prioritization depending on whether the relevant functions exist on the product or not. 1-Cooking with eco-fan, 2- Turbo slow cooking, 3- Turbo cooking, 4- Fan assisted bottom/top heating, 5-Top and bottom heating.

** See. *Installation, page 12.*



Technical specifications may be changed without prior notice to improve the quality of the product.



Figures in this manual are schematic and may not exactly match your product.



Values stated on the product labels or in the documentation accompanying it are obtained in laboratory conditions in accordance with relevant standards. Depending on operational and environmental conditions of the product, these values may vary.

3 Installation

Product must be installed by a qualified person in accordance with the regulations in force. The manufacturer shall not be held responsible for damages arising from procedures carried out by unauthorized persons which may also void the warranty.



Preparation of location and electrical installation for the product is under customer's responsibility.



DANGER:

The product must be installed in accordance with all local electrical regulations.



DANGER:

Prior to installation, visually check if the product has any defects on it. If so, do not have it installed.

Damaged products cause risks for your safety.

Before installation

The appliance is intended for installation in commercially available kitchen cabinets. A safety

distance must be left between the appliance and the kitchen walls and furniture. See figure (values in mm).

- Surfaces, synthetic laminates and adhesives used must be heat resistant (100 °C minimum).
- Kitchen cabinets must be set level and fixed.
- If there is a drawer beneath the oven, a shelf must be installed between oven and drawer.
- Carry the appliance with at least two persons.



Do not install the appliance next to refrigerators or freezers. The heat emitted by the appliance will lead to an increased energy consumption of cooling appliances.



The door and/or handle must not be used for lifting or moving the appliance.



If the appliance has wire handles, push the handles back into the side walls after moving the appliance.

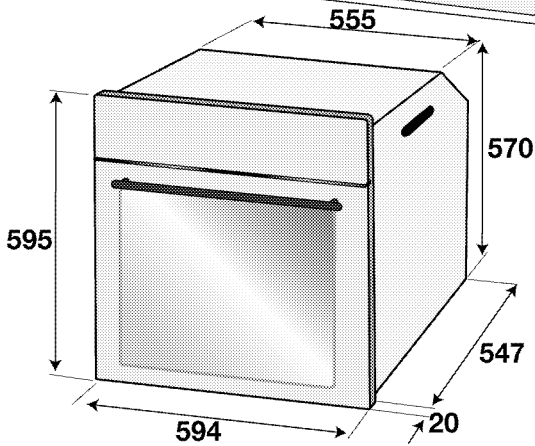
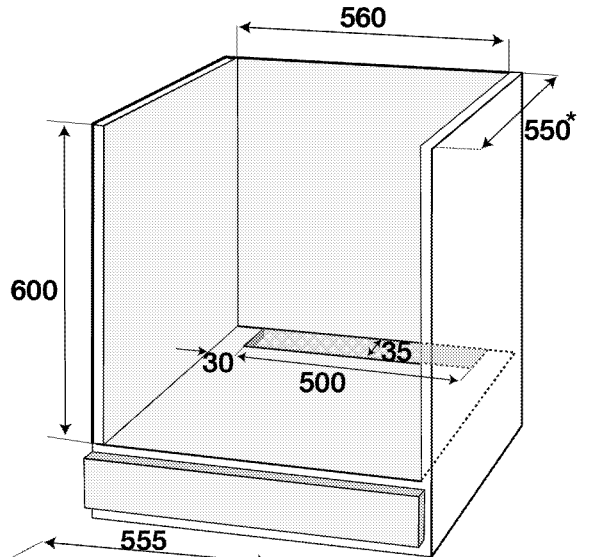
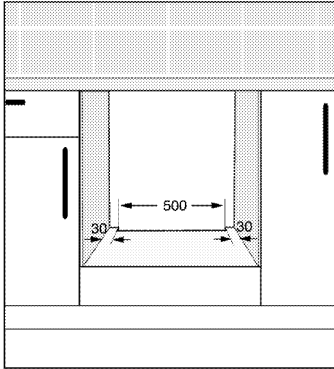
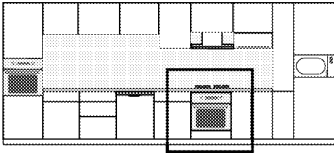

* min.

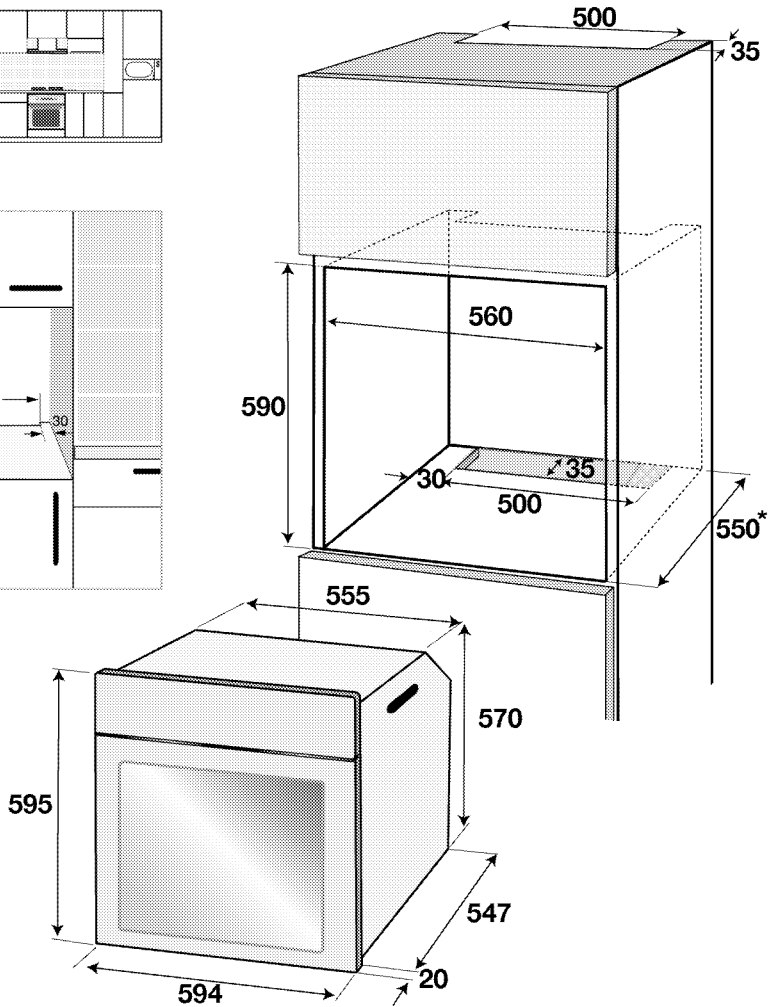
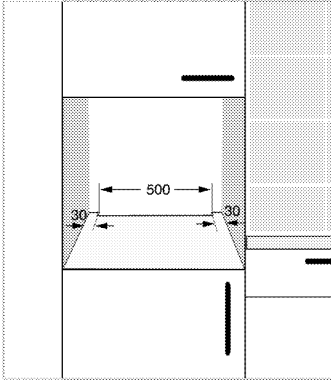
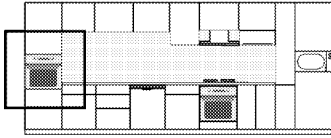

* min.

Installation and connection

- The product must be installed in accordance with all local gas and electrical regulations.

Electrical connection

Connect the product to a grounded outlet/line protected by a miniature circuit breaker of suitable capacity as stated in the "Technical specifications" table. Have the grounding installation made by a qualified electrician while using the product with or without a transformer. Our company shall not be liable for any damages that will arise due to using the

product without a grounding installation in accordance with the local regulations.



DANGER:

The product must be connected to the mains supply only by an authorised and qualified person. The product's warranty period starts only after correct installation. Manufacturer shall not be held responsible for damages arising from procedures carried out by unauthorised persons.

**DANGER:**

The power cable must not be clamped, bent or trapped or come into contact with hot parts of the product.

A damaged power cable must be replaced by a qualified electrician. Otherwise, there is risk of electric shock, short circuit or fire!

- Connection must comply with national regulations.
- The mains supply data must correspond to the data specified on the type label of the product. Open the front door to see the type label.
- Power cable of your product must comply with the values in "Technical specifications" table.

**DANGER:**

Before starting any work on the electrical installation, disconnect the product from the mains supply.

There is the risk of electric shock!

Connecting the power cable

While performing the wiring, you must apply with the national/local electrical regulations and must use the appropriate socket outlet/line and plug for oven. In case of the product's power limits are out of current carrying capability of plug and socket outlet/line, the product must be connected through fixed electrical installation directly without using plug and socket outlet/line.

1. If it is not possible to disconnect all poles in the supply power, a disconnection unit with at least 3 mm contact clearance (fuses, line safety switches, contactors) must be connected and all the poles of this disconnection unit must be adjacent to (not above) the product in accordance with IEE directives. Failure to obey this instruction may cause operational problems and invalidate the product warranty.

Additional protection by a residual current circuit breaker is recommended.

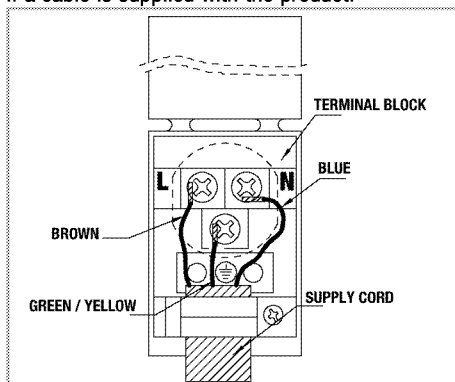
If a cable is supplied with the product:

2. **For single-phase connection**, connect the wires as identified below:

- Brown/Black cable = L (Phase)
- Blue/Grey cable = N (Neutral)
- Green/yellow cable = (E) (Ground)

» or

- Grey/Black cable = L (Phase)
- Blue/Brown cable = N (Neutral)
- Green/yellow cable = (E) (Ground)

Installing the product

1. Slide the oven into the cabinet, align and secure it while making sure that the power cable is not broken and/or trapped.

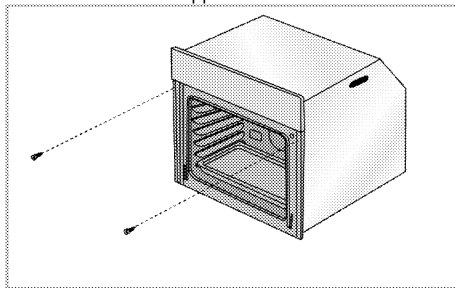

Secure the oven with 2 screws as illustrated.

After the installation, make sure that the screws are sufficiently tightened and the oven does not move. Oven may tip over during use if it is not installed as per the instructions and if the screws are not sufficiently tightened.

For products with cooling fan (This may not exist on your product.)

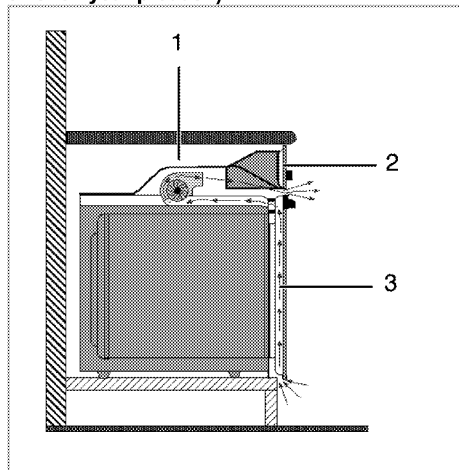

- 1 Cooling fan
- 2 Control panel
- 3 Door

The built-in cooling fan cools both the built-in cabinet and the front of the product.



Cooling fan continues to operate for about 20-30 minutes after the oven is switched off. If you have cooked by programming the timer of the oven, cooling fan will also be switched off at the end of the cooking time together with all functions.

Final check

1. Operate the product.
2. Check the functions.

Future Transportation

- Keep the product's original carton and transport the product in it. Follow the instructions on the carton. If you do not have the original carton, pack the product in bubble wrap or thick cardboard and tape it securely.
- To prevent the wire grill and tray inside the oven from damaging the oven door, place a strip of cardboard onto the inside of the oven door that lines up with the position of the trays. Tape the oven door to the side walls.
- Do not use the door or handle to lift or move the product.



Do not place any objects onto the product and move it in upright position.



Check the general appearance of your product for any damages that might have occurred during transportation.

4 Preparation

Tips for saving energy

The following information will help you to use your appliance in an ecological way, and to save energy:

- Use dark coloured or enamel coated cookware in the oven since the heat transmission will be better.
- While cooking your dishes, perform a preheating operation if it is advised in the user manual or cooking instructions.
- Do not open the door of the oven frequently during cooking.
- Try to cook more than one dish in the oven at the same time whenever possible. You can cook by placing two cooking vessels onto the wire shelf.
- Cook more than one dish one after another. The oven will already be hot.
- You can save energy by switching off your oven a few minutes before the end of the cooking time. Do not open the oven door.
- Defrost frozen dishes before cooking them.

Initial use

Time setting



While making any adjustment, related symbols will flash on the display.

Press **+**/**-** keys to set the time of the day after the oven is energized for the first time.



For touch control models, touch  first and then use **+**/**-** to set the time of the day.

Confirm the setting by touching  symbol and wait for 4 seconds without touching any keys to confirm.

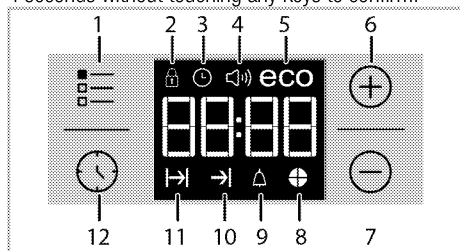

- 1 Adjustment key
- 2 Key lock symbol
- 3 Clock symbol
- 4 Alarm volume symbol (This may not exist on your product.)

- 5 Eco mode symbol
- 6 Plus key
- 7 Minus key
- 8 Time slice symbol
- 9 Alarm symbol
- 10 End of Cooking Time symbol
- 11 Cooking Time symbol
- 12 Program key



If the initial time is not set, clock will run starting from **12:00** and  symbol will be displayed. The symbol will disappear once the time is set.



Current time settings are canceled in case of power failure. It needs to be readjusted.

First cleaning of the appliance



The surface might get damaged by some detergents or cleaning materials.

Do not use aggressive detergents, cleaning powders/creams or any sharp objects during cleaning.

Do not use harsh abrasive cleaners or sharp metal scrapers to clean the oven door glass since they can scratch the surface, which may result in shattering of the glass.

1. Remove all packaging materials.
2. Wipe the surfaces of the appliance with a damp cloth or sponge and dry with a cloth.

Initial heating

Heat up the product for about 30 minutes and then switch it off. Thus, any production residues or layers will be burnt off and removed.



WARNING

Hot surfaces cause burns!

Product may be hot when it is in use. Never touch the hot burners, inner sections of the oven, heaters and etc. Keep children away. Always use heat resistant oven gloves when putting in or removing dishes into/from the hot oven.

Electric oven

1. Take all baking trays and the wire grill out of the oven.
2. Close the oven door.

3. Select Static position.
4. Select the highest grill power; See *How to operate the electric oven, page 19*.
5. Operate the oven for about 30 minutes.
6. Turn off your oven; See *How to operate the electric oven, page 19*

Grill oven

1. Take all baking trays and the wire grill out of the oven.
2. Close the oven door.
3. Select the highest grill power; see *How to operate the grill, page 24*.
4. Operate the grill about 15 minutes.
5. Turn off your grill; see *How to operate the grill, page 24*



Smoke and smell may emit for a couple of hours during the initial operation. This is quite normal. Ensure that the room is well ventilated to remove the smoke and smell. Avoid directly inhaling the smoke and the smell that emits.

5 How to operate the oven

General information on baking, roasting and grilling



WARNING

Hot surfaces cause burns!
Product may be hot when it is in use. Never touch the hot burners, inner sections of the oven, heaters and etc. Keep children away. Always use heat resistant oven gloves when putting in or removing dishes into/from the hot oven.



DANGER:

Be careful when opening the oven door as steam may escape.
Exiting steam can scald your hands, face and/or eyes.

Tips for baking

- Use non-sticky coated appropriate metal plates or aluminum vessels or heat-resistant silicone moulds.
- Make best use of the space on the rack.
- Place the baking mould in the middle of the shelf.
- Select the correct rack position before turning the oven or grill on. Do not change the rack position when the oven is hot.
- Keep the oven door closed.

Tips for roasting

- Treating whole chicken, turkey and large piece of meat with dressings such as lemon juice and black pepper before cooking will increase the cooking performance.
- It takes about 15 to 30 minutes longer to roast meat with bones when compared to roasting the same size of meat without bones.
- Each centimeter of meat thickness requires approximately 4 to 5 minutes of cooking time.
- Let meat rest in the oven for about 10 minutes after the cooking time is over. The juice is better distributed all over the roast and does not run out when the meat is cut.
- Fish should be placed on the middle or lower rack in a heat-resistant plate.

Tips for grilling

When meat, fish and poultry are grilled, they quickly get brown, have a nice crust and do not get dry. Flat pieces, meat skewers and sausages are particularly

suitable for grilling as are vegetables with high water content such as tomatoes and onions.

- Distribute the pieces to be grilled on the wire shelf or in the baking tray with wire shelf in such a way that the space covered does not exceed the size of the heater.
- Slide the wire shelf or baking tray with grill into the desired level in the oven. If you are grilling on the wire shelf, slide the baking tray to the lower rack to collect fats. The baking tray to be slid must be of a size that covers the whole grilling area. This tray might not be provided with the product. Add some water in the baking tray for easy cleaning.



Foods that are not suitable for grilling carry the risk of fire. Only grill food which is suitable for intensive grilling heat.

Do not place the food too far in the back of the grill. This is the hottest area and fatty food may catch fire.

How to operate the electric oven

Select temperature and operating mode

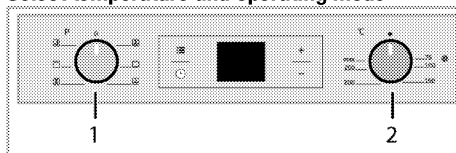

- 1 Function knob
- 2 Thermostat knob

1. Set the Function knob to the desired operating mode.
2. Set the Temperature knob to the desired temperature.

» Oven heats up to the adjusted temperature and maintains it. During heating, temperature lamp stays on.

Switching off the electric oven

Turn the function knob and temperature knob to off (upper) position.

Rack positions (For models with wire shelf)

It is important to place the wire shelf onto the side rack correctly. Wire shelf must be inserted between the side racks as illustrated in the figure.

Do not let the wire shelf stand against the rear wall of the oven. Slide your wire shelf to the front section of the rack and settle it with the help of the door in order to obtain a good grill performance.

(Varies depending on the product model.)

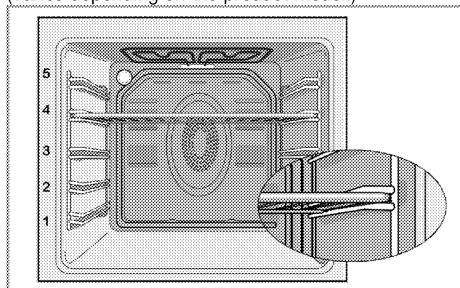

Operating modes

The order of operating modes shown here may be different from the arrangement on your product.

Top and bottom heating



Top and bottom heating are in operation. Food is heated simultaneously from the top and bottom. For example, it is suitable for cakes, pastries, or cakes and casseroles in baking moulds. Cook with one tray only.

Bottom heating



Only bottom heating is in operation. It is suitable for pizza and for subsequent browning of food from the bottom.

This function must be used for easy steam cleaning as well.



Fan supported bottom/top heating



Top heating, bottom heating plus fan (in the rear wall) are in operation. Hot air is evenly distributed throughout the oven rapidly by means of the fan. Cook with one tray only.

Full grill



Large grill at the ceiling of the oven is in operation. It is suitable for grilling large amount of meat.

- Put big or medium-sized portions in correct rack position under the grill heater for grilling.
- Turn the food after half of the grilling time.

Grill+Fan



Grilling effect is not as strong as in Full Grill

- Put small or medium-sized portions in correct shelf position under the grill heater for grilling.
- Turn the food after half of the grilling time.

Booster





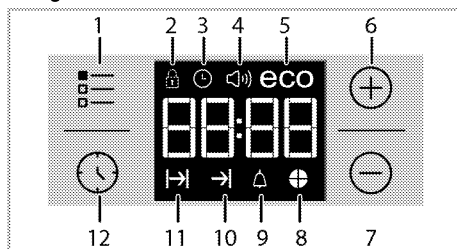

This function is used to heat the oven rapidly; it is not suitable for cooking food.

- Select the desired temperature after selecting this function. Temperature light turns on and oven is heated.
- Light turns off after the heating process is completed. Now select the desired function to cook your food.

Using the oven clock





- 1 Adjustment key
- 2 Key lock symbol
- 3 Clock symbol
- 4 Alarm volume symbol (This may not exist on your product.)
- 5 Eco mode symbol
- 6 Plus key
- 7 Minus key
- 8 Time slice symbol
- 9 Alarm symbol
- 10 End of Cooking Time symbol
- 11 Cooking Time symbol
- 12 Program key

	Maximum time that can be set for end of cooking is 5 hours 59 minutes. Program will be cancelled in case of power failure. You must reprogram the oven.
	While making any setting, related symbols will flash on the display. You must wait for a short time for the settings to take effect.
	If no cooking setting is made, time of the day cannot be set.
	Remaining time will be displayed if cooking time is set when the cooking starts.

Cooking by setting the cooking time;









You can set the oven so that it will stop at the end of the specified time by setting the cooking time on the timer.

1. Select the function for cooking.
2. Touch  until  symbol appears on display for cooking time.
3. Set the cooking time with **+** / **-** keys.
» » After the cooking time is set,  symbol and the time slice will appear on display continuously.
4. Place the dish into the oven and set the temperature with temperature knob. Cooking will start.

» Cooking time starts to count down on display when cooking starts and all parts of time slice symbol is lit. The set cooking time is divided into 4 equal parts and when the time of each parts ends, the symbol of that parts turns off. So you can understand the ratio of remaining cooking time to total cooking time easily.

Setting the the end of cooking time to a later time;

After setting the cooking time on the timer, you can set the end of cooking time to a later time.

1. Select the function for cooking.
2. Touch  until  symbol appears on display for cooking time.
3. Set the cooking time with **+** / **-** keys.
» » Once the Cooking Time is set,  symbol will appear on display continuously.
4. Touch  until  symbol appears on display for the end of cooking time.
5. Press **+** / **-** keys to set the end of cooking time.
» After the cooking time is set,  symbol plus  symbol and the time slice will appear on display continuously. Once the cooking starts,  symbol disappears.

6. Place the dish into the oven and set the temperature with temperature knob. Cooking will start.

» **Oven timer calculates the startup time by deducting the cooking time from the end of cooking time you have set.** Selected operating mode is activated when the startup time of cooking has come and the oven is heated up to the set temperature. It maintains this temperature until the end of cooking time.

» Cooking time starts to count down on display when cooking starts and all parts of time slice symbol is lit. The set cooking time is divided into 4 equal parts and when the time of each parts ends, the symbol of that parts turns off. So you can understand the ratio of remaining cooking time to total cooking time easily.



7. After the cooking process is completed, **"End"** appears on the displayed and the timer gives an audio warning.
8. Audio warning sounds for 2 minutes. To stop the audio warning, just press any key. Audio warning will be silenced and current time will be displayed.



If you press any key at the end of the audio warning, the oven will restart operating. Turn the temperature knob and function knob to **"0"** (off) position to switch off the oven in order to prevent re-operation of the oven at the end of warning.

Activating the keylock



You can prevent digital timer from being intervened with by activating the key lock function.

1. Touch  until  symbol appears on display.
» **"OFF"** will appear on the display.
2. Press **+** to activate the key lock.
» Once the key lock is activated, **"On"** appears on the display and the  symbol remains lit.



Digital timer keys are not functional when the key lock is activated. Key lock will not be cancelled in case of power failure.

To deactivate the keylock



1. Touch  until  symbol appears on display.
» **"On"** will appear on the display.
2. Disable the key lock by pressing the **-** key.
» **"OFF"** will be displayed once the keylock is deactivated.

Setting the alarm clock

You can use the timer of the product for any warning or reminder apart from the cooking program.

The alarm clock has no influence on the functions of the oven. It is only used as a warning. For example,

this is useful when you want to turn food in the oven at a certain point of time. Timer will give an audio warning at the end of the set time.

1. Touch  until  symbol appears on display.

 Maximum alarm time can be 23 hours and 59 minutes.

2. Set the alarm duration by using **+** / **-** keys.

 Function keys for alarm tone, time of day, display brightness and temperature keys should be at 0 (OFF) position.

»  symbol will remain lit and the alarm time will appear on the display once the alarm time is set.



3. At the end of the alarm time,  symbol starts flashing and the audio warning is heard.

Turning off the alarm

1. Audio warning sounds for 2 minutes. To stop the audio warning, just press any key.



» Audio warning will be silenced and current time will be displayed.

Cancelling the alarm;

1. Touch  until  symbol appears on display in order to cancel the alarm.
2. Press and hold **■** key until "00:00" is displayed.

 Alarm time will be displayed. If the alarm time and cooking time are set concurrently, shortest time will be displayed.



Changing alarm tone

1. Touch  until  symbol appears on display.
2. Adjust the desired alarm tone with **+** / **-** keys.
3. The tone you have set will be activated in a short time.

» Selected alarm tone will appear as "b-01", "b-02" or "b-03" on the display.

Changing the time of the day

To change the time of the day you have previously set:

1. Touch  until  symbol appears on display.
2. Set the time of the day with **+** / **-** keys.
3. The time you have set will be activated in a short time.

Economy mode

You can save energy with economy mode while cooking by setting cooking time in the oven.

This mode completes the cooking with the inner temperature of the oven by switching off the heaters before the end of cooking time.

Setting the economy mode

1. Touch  symbol until **eco** symbol appears on display.

» "OFF" will appear on the display.

2. Enable economy mode by touching **+** key.

» Once the economy mode is activated, "On" appears on the display and the eco symbol remains lit.

Disabling economy mode

1. Touch  symbol until **eco** symbol appears on display.

» "On" will appear on the display.

2. Disable economy mode by touching **■** key.

» "Off" will be displayed once the eco mode is deactivated.

Setting the screen brightness

(This feature is optional. It may not exist on your product.)

1. Touch  until **d-01** or **d-02** or **d-03** appears on display for display brightness.

2. Set the desired brightness with **+** / **-** keys.

» The time you have set will be activated in a short time.

Cooking times table



The timings in this chart are meant as a guide. Timings may vary due to temperature of food, thickness, type and your own preference of cooking.

Baking and roasting



1st rack of the oven is the **bottom** rack.

Dish	Cooking level number	Accessory to use	Operating mode	Rack position	Temperature (°C)	Cooking time (approx. in min.)
Cakes in tray	One level	Standard tray*		3	180	25 ... 30
Cakes in mould	One level	Cake mold on wire grill**		2	180	40 ... 50
Small cakes	One level	Standard tray*		3	160	25 ... 35
Sponge cake	One level	Round springform pan with a diameter of 26 cm on wire grill**		3	160	25 ... 35
Cookies	One level	Pastry tray*		3	180	25 ... 30
Dough pastry	One level	Standard tray*		2	200	30 ... 40
Rich pastry	One level	Standard tray*		2	200	25 ... 35
Leaven	One level	Standard tray*		2	200	35 ... 45
Lasagna	One level	Glass/metal rectangular pan on wire grill**		2 - 3	200	30 ... 40
Pizza	One level	Standard tray*		2	200 ... 220	15 ... 20
Beef steak (whole) / Roast	One level	Standard tray*		3	25 min. 250/max, then 180 ... 190	100 ... 120
Leg of Lamb (casserole)	One level	Standard tray*		3	25 min. 220 then 180 ... 190	70 ... 90
Roasted chicken (1,8-2 kg)	One level	Standard tray*		2	15 min. 250/max, then 180 ... 190	60 ... 80
Turkey (6.5 kg)	One level	Standard tray*		1	25 min. 250/max, then 180 ... 190	150 ... 210
Fish	One level	Standard tray*		3	200	20 ... 30

It is suggested to perform preheating for all foods.
 * These accessories may not be supplied with the product.
 ** These accessories are not supplied with the product. They are commercially available accessories.

Cooking table for test meals

Meals in this cooking table are prepared according to EN 60350-1 to make it easier for control institutes to test the product

Dish	Cooking level number	Accessory to use	Operating mode	Rack position	Temperature (°C)	Cooking time (approx. in min.)
Shortbread	One level	Standard tray*		3	140	20 ... 30
Small cakes	One level	Standard tray*		3	160	25 ... 35
Sponge cake	One level	Round springform pan with a diameter of 26 cm on wire grill**		3	160	25 ... 35
Apple pie	One level	Round black metal dish with a diameter of 20 cm on wire grill**		2	180	50 ... 60

It is suggested to perform preheating for all foods.
 * These accessories may not be supplied with the product.
 ** These accessories are not supplied with the product. They are commercially available accessories.

Tips for baking cake

- If the cake is too dry, increase the temperature by 10°C and decrease the cooking time.
- If the cake is wet, use less liquid or lower the temperature by 10°C.
- If the cake is too dark on top, place it on a lower rack, lower the temperature and increase the cooking time.
- If cooked well on the inside but sticky on the outside use less liquid, lower the temperature and increase the cooking time.

Tips for baking pastry

- If the pastry is too dry, increase the temperature by 10°C and decrease the cooking time. Dampen the layers of dough with a sauce composed of milk, oil, egg and yoghurt.
- If the pastry takes too long to bake, pay care that the thickness of the pastry you have prepared does not exceed the depth of the tray.
- If the upper side of the pastry gets browned, but the lower part is not cooked, make sure that the amount of sauce you have used for the pastry is not too much at the bottom of the pastry. Try to scatter the sauce equally between the dough layers and on the top of pastry for an even browning.



Cook the pastry in accordance with the mode and temperature given in the cooking table. If the bottom part is still not browned enough, place it on one lower rack next time.

Tips for cooking vegetables

- If the vegetable dish runs out of juice and gets too dry, cook it in a pan with a lid instead of a tray. Closed vessels will preserve the juice of the dish.
- If a vegetable dish does not get cooked, boil the vegetables beforehand or prepare them like canned food and put in the oven.

How to operate the grill



WARNING

Close oven door during grilling.
Hot surfaces may cause burns!

Switching on the grill

1. Turn the Function knob to the desired grill symbol.
2. Then, select the desired grilling temperature.
3. If required, perform a preheating of about 5 minutes.

» Temperature light turns on.

Switching off the grill

1. Turn the Function knob to Off (top) position.



Foods that are not suitable for grilling carry the risk of fire. Only grill food which is suitable for intensive grilling heat.

Do not place the food too far in the back of the grill. This is the hottest area and fatty food may catch fire.

Cooking times table for grilling

Grilling with electric grill

Food	Accessory to use	Rack position	Recommended temperature (°C)**	Cooking time (approx. in min.) [#]
Fish	Wire grill	4..5	250	20...25 min.
Sliced chicken	Wire grill	4..5	250	25...35 min.
Lamb chops	Wire grill	4..5	250	20...25 min.
Roast beef	Wire grill	4..5	250	25...30 min. [#]
Veal chops	Wire grill	4..5	250	25...30 min. [#]
Toast bread*	Wire grill	4	250	1...3 min.

[#]depending on thickness

*Preheat for 5 minutes

**If the grill temperature of your product cannot be adjusted, the grill will work at the recommended temperature.

Meals in this cooking table are prepared according to EN 60350-1 to make it easier for control institutes to test the product

Food	Accessory to use	Rack position	Temperature (°C)	Cooking time (approx. in min.)
Toast bread	Wire grill	4	250	1...3 min.
Meatballs (beef) - 12 pieces	Wire grill	4	250	25...35 min.

Turn the food after 2/3 of the total grilling time.

It is suggested to perform 5 minutes preheating for all foods broiling.

6 Maintenance and care

General information

Service life of the product will extend and the possibility of problems will decrease if the product is cleaned at regular intervals.

 **DANGER:**
Disconnect the product from mains supply before starting maintenance and cleaning works.
There is the risk of electric shock!

 **DANGER:**
Allow the product to cool down before you clean it.
Hot surfaces may cause burns!

- Clean the product thoroughly after each use. In this way it will be possible to remove cooking residues more easily, thus avoiding these from burning the next time the appliance is used.
- No special cleaning agents are required for cleaning the product. Use warm water with washing liquid, a soft cloth or sponge to clean the product and wipe it with a dry cloth.
- Always ensure any excess liquid is thoroughly wiped off after cleaning and any spillage is immediately wiped dry.
- Do not use cleaning agents that contain acid or chloride to clean the stainless or inox surfaces and the handle. Use a soft cloth with a liquid detergent (not abrasive) to wipe those parts clean, paying attention to sweep in one direction.

 The surface might get damaged by some detergents or cleaning materials.
Do not use aggressive detergents, cleaning powders/creams or any sharp objects during cleaning.
Do not use harsh abrasive cleaners or sharp metal scrapers to clean the oven door glass since they can scratch the surface, which may result in shattering of the glass.

 Do not use steam cleaners to clean the appliance as this may cause an electric shock.

Cleaning the control panel

Clean the control panel and knobs with a damp cloth and wipe them dry.

 If your product is equipped with buttons/knobs do not remove the control buttons/knobs to clean the control panel.
Control panel may get damaged!

Cleaning the oven

To clean the side wall (Varies depending on the product model.)

(This feature is optional. It may not exist on your product.)

1. Remove the front section of the side rack by pulling it in the opposite direction of the side wall.
2. Remove the side rack completely by pulling it towards you.

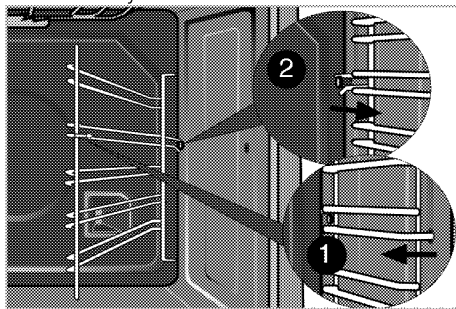

Catalytic walls

(This feature is optional. It may not exist on your product.)

The inner side walls (A) and/or the rear wall (B) of your product may be coated with catalytic enamel. Catalytic walls have a light matte colour and a porous surface. Catalytic walls of the oven should not be cleaned. Thanks to their perforated structure, catalytic surfaces absorb grease and once the surface is filled with grease, they start to shine. In this case, it is recommended to replace the parts.

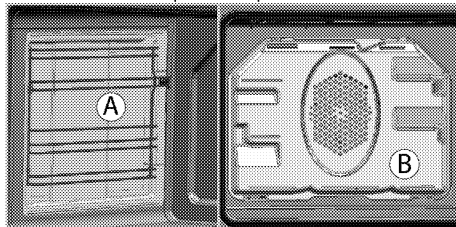

Easy Steam Cleaning

It ensures easy cleaning because the dirt (having waited not for too long) is softened with the steam that forms inside the oven and the water drops condensing on the inner surfaces of the oven.

1. Remove all accessories inside the oven.
2. Pour 500 ml of water into the oven tray and place the tray at the 2nd rack of the oven.

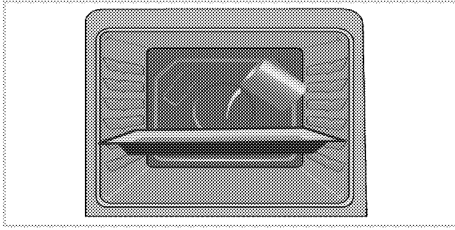

3. Set the oven to easy steam cleaning mode and run at 100°C for 25 minutes.
4. Open the door and wipe the inner surfaces of the oven with a damp sponge or cloth.
5. Use warm water with washing liquid, a soft cloth or sponge to clean the persistent dirt and wipe it with a dry cloth.

i During the easy steam cleaning mode, water that is placed in the tray to soften lightly formed residues/dirt within the oven cavity will evaporate and condense in the oven cavity and inner glass of the oven door, therefore water may drip when the oven door is opened. Wipe away the condensation as soon as the oven door is opened.

Clean oven door

To clean the oven door, use warm water with washing liquid, a soft cloth or sponge to clean the product and wipe it with a dry cloth.

i Don't use any harsh abrasive cleaners or sharp metal scrapers for cleaning the oven door. They could scratch the surface and destroy the glass.

Removing the oven door

1. Open the front door (1).
2. Open the clips at the hinge housing (2) on the right and left hand sides of the front door by pressing them down as illustrated in the figure.

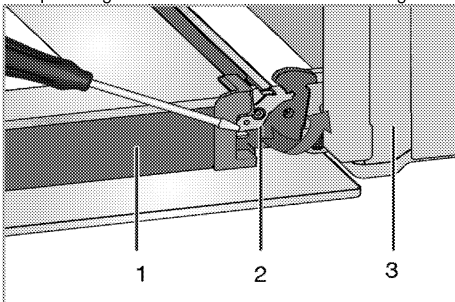

- 1 Door
- 2 Hinge lock(closed position)
- 3 Oven
- 4 Hinge lock(open position)

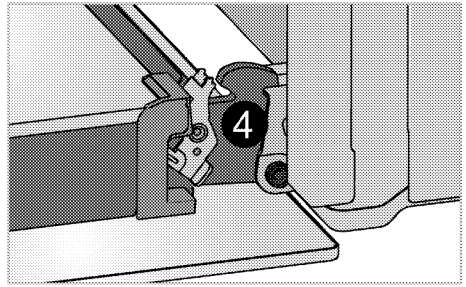

3. Move the front door to half-way.

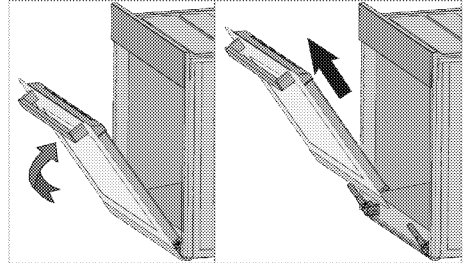

4. Remove the front door by pulling it upwards to release it from the right and left hinges.

i Steps carried out during removing process should be performed in reverse order to install the door. Do not forget to close the clips at the hinge housing when reinstalling the door.

Removing the door inner glass

(This feature is optional. It may not exist on your product.)

The inner glass panel of the oven door can be removed for cleaning.

1. Open the oven door.

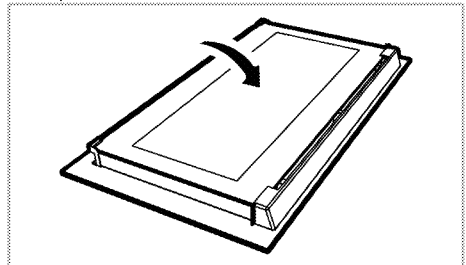

2. Pull towards yourself and remove the plastic part installed to upper section of the front door.

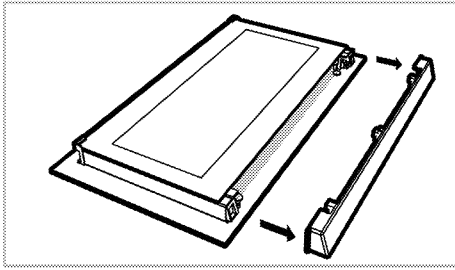

3. As illustrated in figure, raise the innermost glass panel (1) slightly in direction **A** and pull it out in direction **B**.

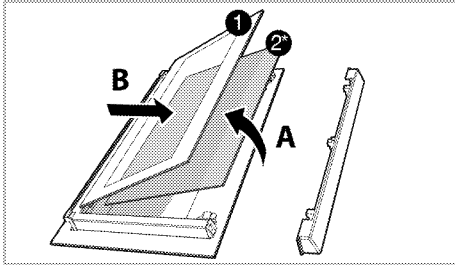

- 1 Innermost glass panel
 2* Inner glass panel (This may not exist on your product.)
4. If your product is equipped with an inner glass panel; repeat the same procedure to remove the inner glass panel (2).
5. The first step to regroup the door is reinstalling inner glass panel (2). Place the chamfered corner of the glass panel so that it will rest in the chamfered corner of the plastic slot. (If your product is equipped with an inner glass panel). Inner glass panel (2) must be installed into the plastic slot close the innermost glass panel (1).
6. When installing the innermost glass panel (1), make sure that the printed side of the panel faces towards the inner glass panel. It is important to seat lower corner of innermost glass panel (1) into the lower plastic slot.
7. Push the plastic part towards the frame until you hear a "click".

Replacing the oven lamp



DANGER:

Before replacing the oven lamp, make sure that the product is disconnected from mains and cooled down in order to avoid the risk of an electrical shock.
 Hot surfaces may cause burns!



In this oven, an incandescent lamp with a power of less than 40 W, a height of less than 60 mm, a diameter of less than 30 mm or a halogen lamp with socket type G9, a power of less than 60 W is used. The lamps are suitable for operation at temperatures above 300 °C. Oven lamps can be obtained from Authorised Service Agents or technician with licence.



Position of lamp might vary from the figure.



The lamp used in this appliance is not suitable for household room illumination. The intended purpose of this lamp is to assist the user to see foodstuffs.



The lamps used in this appliance have to withstand extreme physical conditions such as temperatures above 50 °C.

If your oven is equipped with a round lamp:

1. Disconnect the product from mains.
2. Turn the glass cover counter clockwise to remove it.

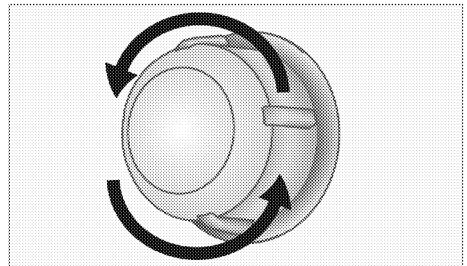

3. If your oven lamp is of type (A) shown in the figure below, remove it by rotating as shown and replace it. If it is of type (B), pull and remove it as shown in the figure and replace it.

7 Troubleshooting

Oven emits steam when it is in use.

- It is normal that steam escapes during operation. >>> *This is not a fault.*

Product emits metal noises while heating and cooling.

- When the metal parts are heated, they may expand and cause noise. >>> *This is not a fault.*

Product does not operate.

- The mains fuse is defective or has tripped. >>> *Check fuses in the fuse box. If necessary, replace or reset them.*
- Product is not plugged into the (grounded) socket. >>> *Check the plug connection.*

Oven light does not work.

- Oven lamp is defective. >>> *Replace oven lamp.*
- Power is cut. >>> *Check if there is power. Check the fuses in the fuse box. If necessary, replace or reset the fuses.*

Oven does not heat.

- Might not be set to a certain cooking function and/or temperature. >>> *Set the oven to a certain cooking function and/or temperature.*
- In models equipped with a timer, the timer is not adjusted. >>> *Adjust the time.*
(In products with microwave oven, timer controls only microwave oven.)
- Power is cut. >>> *Check if there is power. Check the fuses in the fuse box. If necessary, replace or reset the fuses.*

(In models with timer) Clock display is blinking or clock symbol is on.

- A previous power outage has occurred. >>> *Adjust the time / Switch of the product and switch it on again.*



Consult the Authorised Service Agent or technician with licence or the dealer where you have purchased the product if you can not remedy the trouble although you have implemented the instructions in this section. Never attempt to repair a defective product yourself.



Ugradbena pećnica

Uputstvo za upotrebu

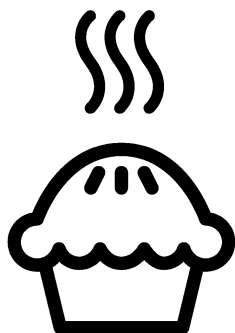

BS

Molimo prvo pročitajte ovaj priručnik za korisnika!

Poštovani Korisniče,

Hvala vam što ste izabrali Beko proizvod. Nadamo se da ćete uživati u najboljim rezultatima vašeg proizvoda koji je proizveden pomoću najmodernije tehnologije visoke kvalitete. Stoga, molimo vas pažljivo pročitajte ovaj cijeli priručnik za korisnika i sve druge prateće dokumente prije upotrebe proizvoda i čuvajte ih kao referencu za buduću upotrebu. Ako uručite ovaj proizvod nekom drugom, također mu/joj predajte i ovaj priručnik za korisnika. Slijedite sva upozorenja i informacije u ovom priručniku za korisnika.

Zapamtite da se ovaj priručnik za korisnika može primijeniti i za nekoliko drugih modela. Razlike između modela će biti identifikovane u ovim uputstvima.

Pojašnjenje simbola

Sljedeći simboli su korišteni u ovom priručniku za korisnika:

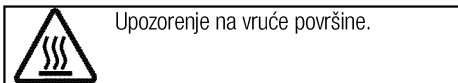
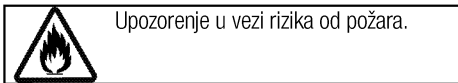
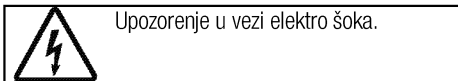
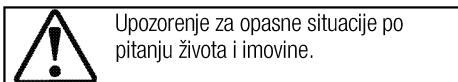
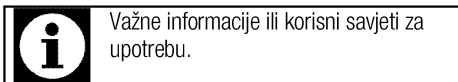

Arçelik A.Ş.
Karaağaç caddesi No:2-6
34445 Sütlüce/Istanbul/TURKEY
Made in TURKEY

1 Važna uputstva i upozorenja za sigurnost i okoliš 4

Opće mjere sigurnosti	4
Električna sigurnost.....	4
Sigurnost proizvoda.....	5
Predviđena upotreba.....	7
Sigurnost za djecu	7
Odlaganje starog proizvoda.....	8
Odlaganje materijala za pakovanje	8

2 Opće informacije 9

Pregled	9
Sadržaj pakovanja.....	10
Tehničke specifikacije	11

3 Instalacija 12

Prije instalacije	12
Instalacija i povezivanje	14
Odlaganje starog proizvoda.....	16

4 Priprema 17

Savjeti za uštedu energije.....	17
Prva upotreba.....	17
Podešavanje vremena	17
Prvo čišćenje uređaja.....	17

Početno zagrijavanje.....	17
---------------------------	----

5 Kako rukovati pećnicom 19

Opće informacije o pečenju, prženju i roštiljanju.....	19
Kako rukovati električnom pećnicom.....	19
Načini rada	20
Upotreba sata pećnice	20
Tabela vremena kuhanja.....	23
Kako rukovati roštiljom	24
Vrijeme pripremanja hrane korištenjem funkcije roštilja	24

6 Održavanje i njega 25

Opšte informacije	25
Čišćenje kontrolne ploče.....	25
Čišćenje pećnice	25
Skidanje vrata pećnice.....	26
Uklanjanje unutrašnjeg stakla na vratima	27
Zamjena svjetla u pećnici.....	27

7 Rješavanje problema 29

1 Važna uputstva i upozorenja za sigurnost i okoliš

Ovaj odjeljak sadrži sigurnosna uputstva koja će vam pomoći da se zaštitite od rizika od lične povrede ili oštećenja imovine. Ne pridržavanje ovih uputstava će poništiti svaku garanciju.

Opće mjere sigurnosti

- Ovaj uređaj mogu koristiti djeca dobi od 8 godina i starija kao i osobe sa reduciranim fizičkim, čulnim ili mentalnim sposobnostima ili sa nedostatkom iskustva i znanja ukoliko im je obezbijeden nadzor ili uputstvo u vezi upotrebe uređaja na bezbjedan način i razumijevanja opasnosti koje mogu biti uključene.
Djeca se ne smiju igrati sa uređajem. Djeca bez nadzora ne smiju obavljati radnje oko čišćenja i održavanja.
- Uređaj nije namijenjen za upotrebu od strane osoba (uključujući djecu) sa smanjenim fizičkim, osjetilnim ili mentalnim sposobnostima ili s nedostatkom iskustva i znanja, osim ako su pod nadzorom ili ako su instruirani po pitanju upotrebe uređaja. Djeca koju nadgledate ne smiju se igrati s uređajem.
- Ako je proizvod uručen nekom drugom za ličnu upotrebu ili da se

koristi kao rabljeni proizvod, takođe treba uručiti priručnik za korisnika, oznake proizvoda i druge relevantne dokumente kao i dijelove proizvoda .

- Postupke ugradnje i opravke uvijek moraju izvoditi ovlašteni serviseri. Proizvođač se neće držati odgovornim za oštećenja nastala usljed procedura koje su izvodile neovlaštene osobe što takođe može prouzrokovati da garancija bude nevažeća. Prije ugradnje, pažljivo pročitajte uputstva.
- Nemojte koristiti uređaj ukoliko je u kvaru ili ako na njemu ima vidljivih oštećenja.
- Uvjerite se da su funkcijske tipke proizvoda isključene nakon svake upotrebe.

Električna sigurnost

- Ukoliko proizvod ima grešku, ne bi trebalo njim rukovati dok se greška ne popravi od strane zastupnika iz ovlaštenog servisa. Postoji rizik od elektro šoka!
- Proizvod spojite samo na uzemljeni izlaz/vod s naponom i zaštito kao što je specificirano u odjeljku "Tehničke specifikacije". Neka uzemljenje izvrši kvalifikovani električar dok se proizvod koristi sa ili bez

transformatora. Naša kompanija neće biti odgovorna za bilo kakve probleme nastale zbog toga što proizvod nije bio uzemljen u skladu sa lokalnim regulativama.

- Nikada ne perite proizvod poljevanjem ili posipanjem vode po njemu! Postoji rizik od elektro šoka!
- Proizvod mora biti iskopčan za vrijeme ugradnje, održavanja, čišćenja i popravke.
- Ako je napojni kabal za priključivanje proizvoda oštećen, isti se mora zamijeniti od strane proizvođača, njegovog zastupnika ili sličnih kvalifikovanih osoba da bi se izbjegli neželjeni rizici.
- Uređaj mora biti ugrađen tako da se može u potpunosti iskopčati sa mreže. Separacija mora biti obezbijeđena bilo pomoću glavnog utikača, bilo pomoću sklopke ugrađene u fiksnu električnu instalaciju, u skladu sa konstrukcionim propisima.
- Stražnja površina pećnice zagrije se prilikom korištenja. Budite sigurni da električni priključak nema kontakta sa stražnjom površinom; u suprotnom, spoj se može oštetiti.
- Nemojte dozvoliti da se napojni kabal zaglavi između vrata pećnice i okvira i nemojte voditi kabal preko toplih površina. U

suprotnom, izolacija kabla bi se mogla istopiti što može izazvati požar kao rezultat kratkog spoja.

- Sve radove na električnoj opremi i sistemima trebaju izvoditi samo ovlaštene i kvalificirane osobe.
- U slučaju bilo kakvog oštećenja, isključite uređaj i iskopčajte ga sa napajanja. Da biste ovo uradili, isključite osigurač u kući.
- Provjerite da je jačina osigurača kompatibilna sa vašim proizvodom.

Sigurnost proizvoda

- **UPOZORENJE:** Uređaj i njegovi dostupni dijelovi postaju vrelli za vrijeme upotrebe. Potrebno je voditi računa da bi se izbjeglo dodirivanje grijnih elemenata. Djecu mlađu od 8 godina treba držati dalje od uređaja ukoliko nisu pod stalnim nadzorom.
- Osobe čije su prosudbe ili koordinacija smanjene pod uticajem alkohola i/ili droga ne smiju koristiti uređaj.
- Budite oprezni kada koristite alkoholna pića u vašem posudu. Alkohol isparava na visokim temperaturama i može izazvati požar jer se zapali kada stupi u kontakt sa vrućim površinama.
- Nemojte stavljati nikakve zapaljive materijale u blizini proizvoda jer i bočne strane mogu postati vruće tokom upotrebe.

- Uređaj postaje vruć za vrijeme upotrebe. Potrebno je voditi računa da bi se izbjeglo dodirivanje grijnih elemenata unutar pećnice.
- Držite sve otvore za ventilaciju očišćenim od prepreka.
- Nemojte zagrijavati zatvorene konzerve niti staklene posude u pećnici. Pritisak koji se može stvoriti u tim konzervama/posudama može dovesti do njihovog pucanja.
- Nemojte stavljati pladnjeve za pečenje, posuđe ili aluminijsku foliju direktno na dno pećnice. Akumuliranje toplote moglo bi uzrokovati oštećenja na dnu pećnice.
- Nemojte koristiti gruba abrazivna sredstva za čišćenje ili oštre metalne strugače da čistite staklo na vratima pećnice jer oni mogu izgubiti površinu, što može rezultirati lomom na staklu.
- Nemojte koristiti čistače na paru da čistite uređaj jer bi to moglo prouzrokovati strujni udar.
- (Varira u ovisnosti od modela proizvoda.)
Ispravno postavljanje žičanog nosača i pladnja na stalke za rešetku
Važno je da se žičana rešetka i/ili pladanj postave ispravno na stalak. Umetnite žičanu rešetku ili

pladanj između 2 tračnice i osigurajte da bude uravnoteženo prije nego stavite hranu na to (Molimo pogledajte slijedeću sliku).

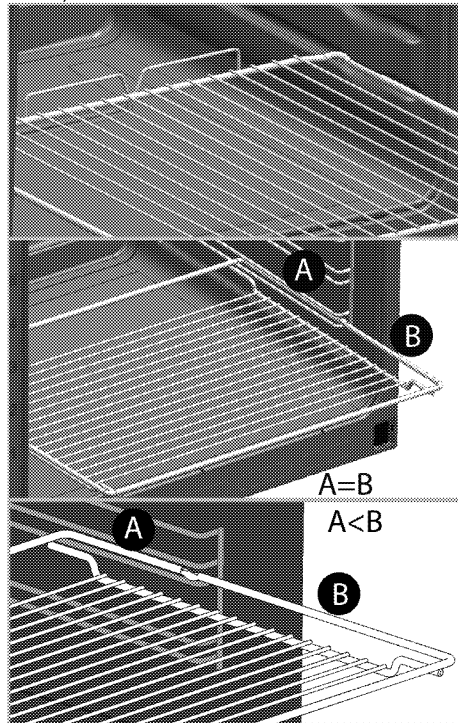

- Nemojte koristiti proizvod ukoliko je staklo na prednjim vratima uklonjeno ili slomljeno.
- Uvijek koristite rukavice za pećnicu otporne na vrućinu kada stavljate ili uklanjate posuđe u/iz vrele pećnice.
- Postavite papir za pečenje u posudu za kuhanje ili na dodatnu opremu pećnice (pladanj, žičanu rešetku itd.) zajedno s hranom i potom ubacite sve u prethodno zagrijanu pećnicu. Uklonite višak

dijelova papira za pečenje koji se preljeva izvan dodatne opreme ili posude da bi se spriječio rizik dodirivanja grijnih elemenata pećnice. Nikada ne koristite papir za pečenje na radnoj temperaturi koja je viša od naznačene vrijednosti za papir za pečenje. Nemojte stavljati papir za pečenje direktno na bazu pećnice.

- UPOZORENJE: Prije zamjene lampice, uvjerite se da je napojni kabl uređaja isključen iz utičnice ili da je automatska sklopka isključena kako biste izbjegli mogućnost strujnog udara.
- Uređaj ne smije biti instaliran iza dekorativnih vrata kako bi se izbjeglo pregrijavanje.

Za sigurnost od požara na proizvodu;

- Provjerite da li utikač odgovara utičnici kao i to da ne uzrokuje iskrenje.
- Ne upotrebljavajte oštećen ili sječen ili produžni kabal osim originalnog kabla.
- Budite sigurni da tečnost ili vlaga na utičnici ne dospiju u proizvod preko utikača.

Predviđena upotreba

- Ovaj proizvod je dizajniran za upotrebu u domaćinstvu. Komercijalna upotreba nije dopuštena.
- OPREZ: Ovaj uređaj je samo za kuhanje. On se ne smije koristiti u

druge svrhe, na primjer grijanje prostorije.

- Uređaj se ne smije koristiti za zagrijavanje tanjira ispod roštilja, sušenje peškira ili krpa itd. vješanjem istih na ručkama kao ni u svrhu zagrijavanja.
- Proizvođač nije odgovoran za bilo kakve štete uzrokovane nepropisnim korištenjem ili greškama pri rukovanju.
- Uređaj se može koristiti za odmrzavanje, pečenje, prženje i roštiljanje hrane.

Sigurnost za djecu

- UPOZORENJE: Pristupačni dijelovi mogu postati vrući tokom upotrebe. Malu djecu treba držati dalje od uređaja.
- Ambalažni materijali mogu predstavljati opasnost za djecu. Držite ambalažne materijale dalje od dohvata djece. Molimo odložite sve dijelove pakovanja i sklada sa ekološkim propisima.
- Električni proizvodi predstavljaju opasnost za djecu. Držite djecu dalje od proizvoda kada je on u funkciji i nemojte dozvoliti djeci da se igraju s tim proizvodom.
- Ne ostavljajte iznad uređaja bilo kakve predmete koje djeca mogu dosegnuti.
- Kada su vrata otvorena, nemojte stavljati bilo kakve teške predmete na njih i ne dajte djeci

da sjedaju na njih. Vrata se mogu oboriti ili se mogu oštetiti šarke na vratima.

Odlaganje starog proizvoda

Usklađenost sa WEEE Direktivom i odlaganje otpadnog proizvoda:



Ovaj proizvod je u skladu sa EU WEEE Direktivom (2012/19/EU). Ovaj proizvod posjeduje klasifikacijski simbol za otpadnu električnu i elektroničku opremu (WEEE).

Ovaj proizvod je proizveden od visoko kvalitetnih dijelova koji se mogu ponovo upotrijebiti i koji su pogodni za recikliranje. Nemojte odlagati otpadni proizvod s običnim kućnim i drugim otpadima čiji je

vijeka trajanja prošao. Odnosite taj otpad na odlagalište za reciklažu električne i elektroničke opreme. Molimo vas posavjetujte se sa lokalnim institucijama da saznate gdje se nalaze ova odlagališta.

Usklađenost sa RoHS Direktivom:

Proizvod koji ste kupili je u skladu sa EU RoHS Direktivom (2011/65/EU). On ne sadrži nikakve štetne i zabranjene materijale specificirane u ovoj Direktivi.

Odlaganje materijala za pakovanje

- Materijal za pakovanje predstavlja opasnost po djecu. Čuvajte materijal za pakovanje na sigurnom mjestu van dohvata djece. Materijali za pakovanje ovog proizvoda napravljeni su od reciklirajućeg materijala. Pravilno ih odložite i sortirajte ih u skladu sa uputstvima za reciklažu otpada. Nemojte ih odlagati zajedno sa običnim kućnim otpadom.

2 Opće informacije

Pregled

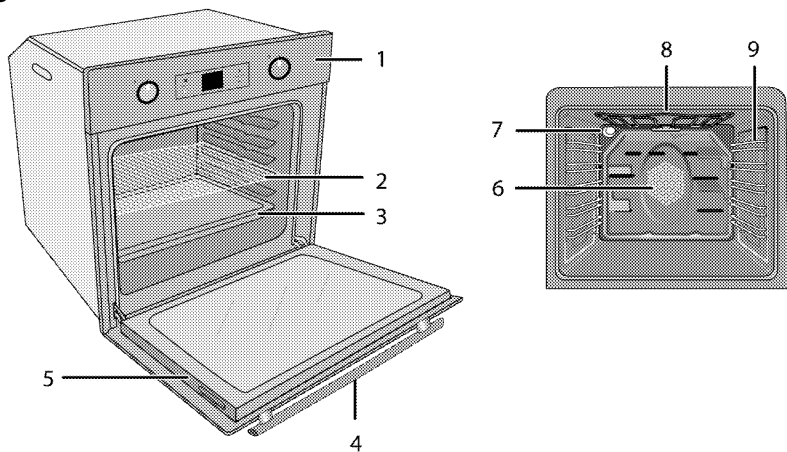

- 1 Upravljačka ploča
- 2 Žičani nosač
- 3 Pladanj
- 4 Drška
- 5 Vrata

- 6 Motor ventilatora (iza čelične ploče)
- 7 Lampa
- 8 Grijni element na vrhu
- 9 Položaji police

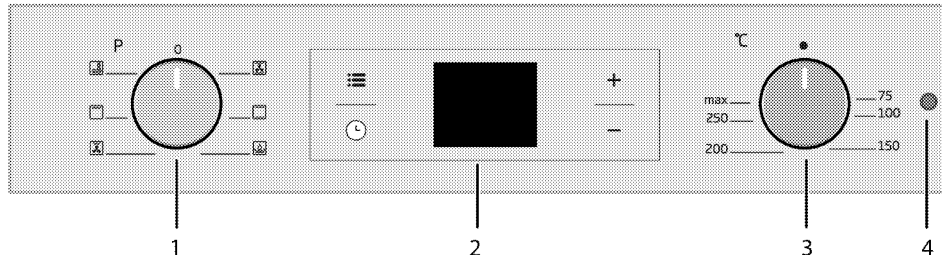

- 1 Funkcijska sklopka
- 2 Digitalni mjerač vremena
- 3 Termostatska sklopka
- 4 Termostatska lampa

Sadržaj pakovanja



Isporučeni pribor se može razlikovati ovisno od modela proizvoda. Svaki komad dodatnog pribora koji je opisan u priručniku za korisnika ne mora biti isporučen uz vaš proizvod.

1. **Uputstvo za upotrebu**

2. **Standardni pladanj**

Upotrebljava se za peciva, zamrznutu hranu i velike pečenice.

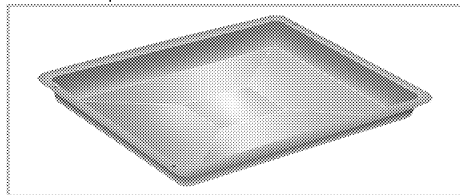

3. **Duboki pladanj**

Upotrebljava se za peciva, velike pečenice, sočna jela, kao i za prikupljanje masnoće tokom roštiljanja.

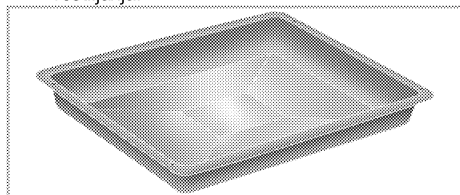

4. **Rešetka roštilja**

Upotrebljava se za prženje i za postavljanje hrane koju treba peći, pržiti ili kuhati u loncu na željenoj polici.

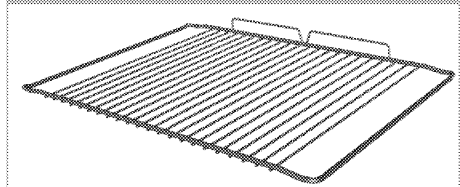
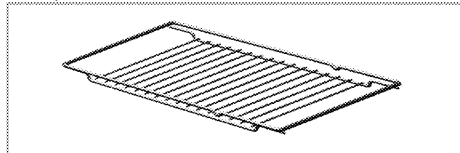

5. **Ispravno postavljanje žičanog nosača i pladnja na teleskopske stalke**
(Ova funkcija je opcionalna. Ona se možda neće nalaziti na vašem proizvodu.)

Teleskopski stalci omogućavaju vam da lako postavite i uklonite pladnjeve i žičani nosač. Kada koristite pladnjeve i žičani nosač sa teleskopskim stalcima, osigurajte da zakačke na stražnjem odjeljku teleskopskog stalka stoje nasuprot rubova žičanog nosača i pladnja.

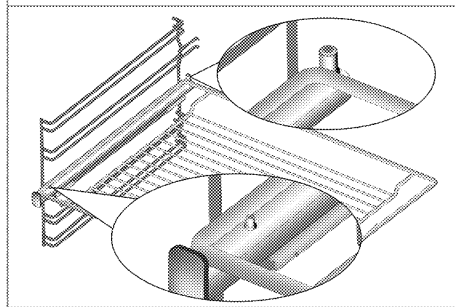
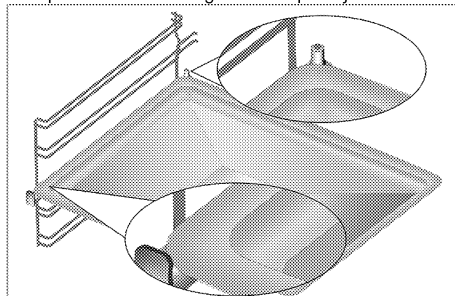

Tehničke specifikacije

Napon/frekvencija	220-240 V ~ 50 Hz
Ukupna potrošnja električne energije	2.4 kW
Vrsta kabla/poprečni presjek	min.H05W-FG 3 x 1,5 mm ²
Vanjske dimenzije (visina/širina/dubina)	595 mm/594 mm/567 mm
Dimenzije za ugradnju (visina/širina/dubina)	**590 ili 600 mm/560 mm/min. 550 mm
Glavna pećnica	Multifunkcijska pećnica
Unutrašnja lampica	15/25 W
Potrošnja električne energije roštilja	2.2 kW

Osnove: Informacije o električnim pećnicama na etiketi o energiji date su u skladu sa EN 60350-1 / IEC 60350-1 standardima. Te vrijednosti su determinirane pod standardnim opterećenjem sa donjim-gornjim grijačima ili funkcijama zagrijavanja potpomognutim ventilatorom (ukoliko postoje). Klasa energetske efikasnosti je determinirana u skladu sa slijedećim prioritetima što zavisi od toga da li relevantne funkcije postoje na uređaju ili ne. 1-Kuhanje uz eco-ventilator, 2- Turbo sporo kuhanje, 3- Turbo kuhanje, 4- Zagrijavanje donje/gornje površine potpomognuto ventilatorom, 5- Zagrijavanje donje i gornje površine.

** Pogledajte . *Instalacija, Stranica 12.*



Tehničke specifikacije su podložne izmjenama bez prethodne obavijesti kako bi se poboljšao kvalitet uređaja.



Slike u ovom priručniku su shematske i moguće je da se ne podudaraju tačno s vašim uređajem.



vrijednosti prikazane na naljepnicama uređaja ili u priloženoj dokumentaciji postignute su u laboratorijskim uvjetima u skladu sa relevantnim standardima. Ovisno o uvjetima okoline i rada uređaja, ove vrijednosti mogu varirati.

3 Instalacija

Proizvod mora biti ugrađen od strane ovlaštene osobe u skladu sa propisima koji su na snazi. U suprotnom, garancija će postati nevažeća. Proizvođač se neće držati odgovornim za oštećenja nastala usljed procedura koje su izvodile neovlaštene osobe i garancija može biti nevažeća.



Priprema lokacije i elektro instalacije za ovaj proizvod je u nadležnosti korisnika.



OPASNOST:

Prilikom instalacije, uređaj mora biti spojen u skladu sa svim lokalnim propisima o plinskim i/ili električnim instalacijama.



OPASNOST:

Prije instalacije, izvršiti vizuelno provjeru da li na proizvodu ima bilo kakvih nedostataka. Ako da, nemojte vršiti instalaciju. Oštećeni proizvodi predstavljaju rizik za vašu sigurnost.

Prije instalacije

Uređaj je namijenjen za instaliranje u komercijalno dostupnim kuhinjskim kabinetima. Između uređaja i kuhinjskih zidova i namještaja mora se ostaviti dovoljno prostora radi sigurnosti. Pogledati sliku (mjere u mm).

- Površine, sintetički laminati i ljepila moraju biti otporna na toplotu (minimalno 100 °C).
- Kuhinjski ormarići moraju biti postavljeni u ravninu i učvršćeni.
- Ako se ispod pećnice nalazi ladica, mora se instalirati polica između pećnice i ladice.
- Uređaj trebaju prenositi najmanje dvije osobe.



Nemojte instalirati proizvod pored frižidera ili zamrzivača. Toplota koju emitira vaš proizvod će povećati potrošnju energije uređaja za rashlađivanje.



Ne koristite vrata i/ili ručku da biste prenosili ili premještali ovaj proizvod.



Ako proizvod ima žičane ručke, gurnite ručke u bočne zidove nakon pomjeranja proizvoda.

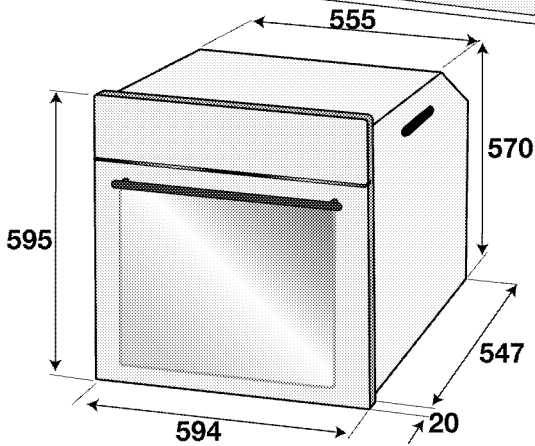
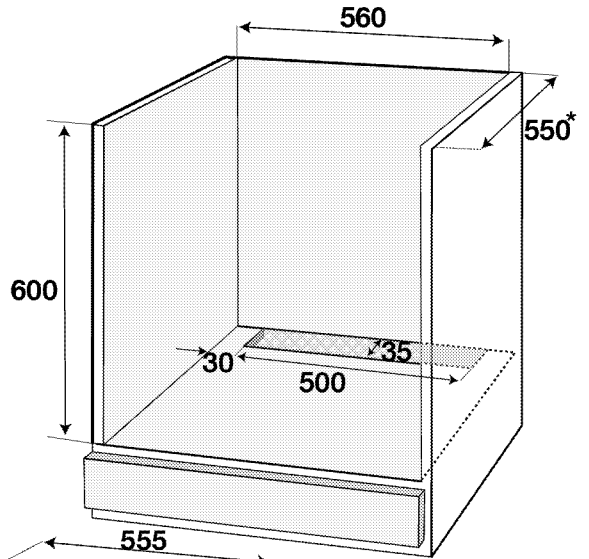
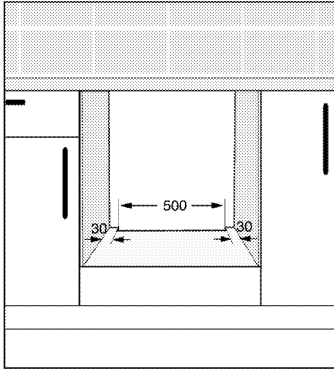
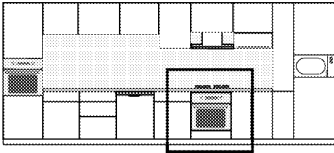

* min.

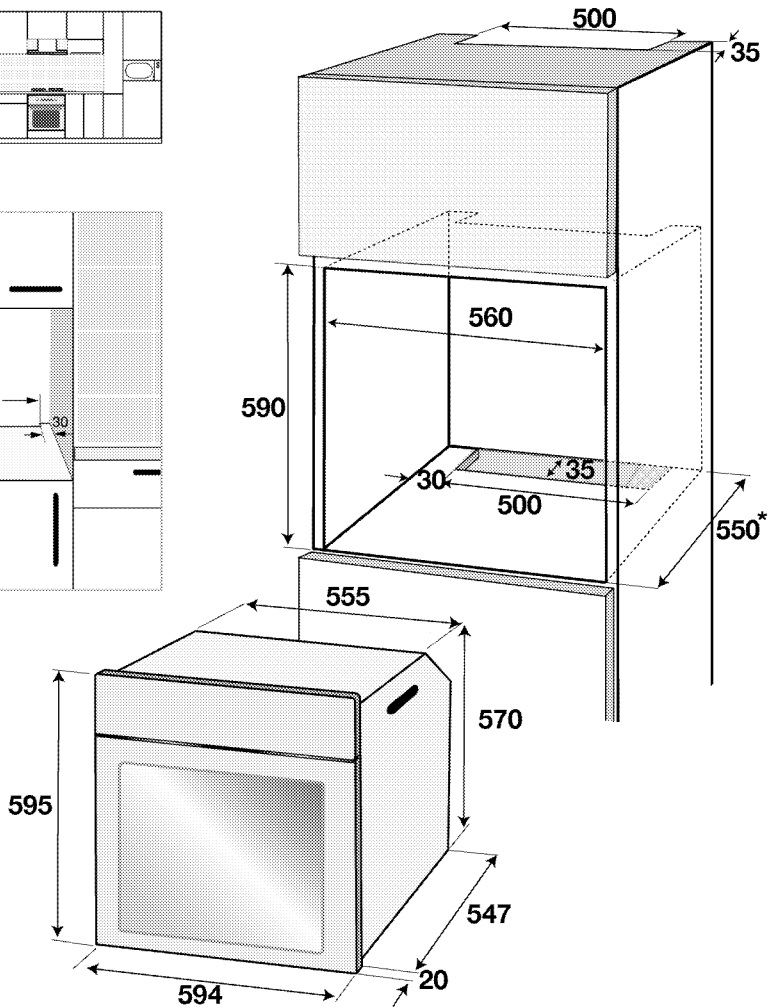
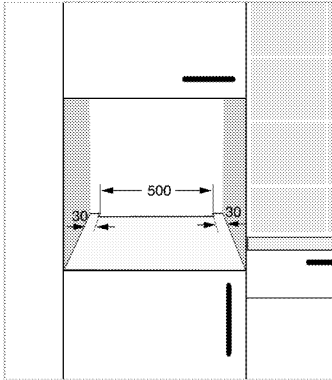
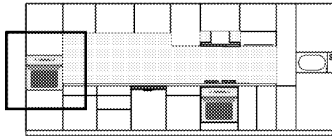

* min.

Instalacija i povezivanje

- Proizvod se isključivo može instalirati i priključiti u skladu sa statutarim pravilima instalacije.

Električno spajanje

Priključite proizvod na uzemljenu utičnicu/vod koji su zaštićeni minijaturnom automatskom sklopkom odgovarajućeg kapaciteta kao što je navedeno u tabeli "Tehničke specifikacije". Neka uzemljenje uradi kvalifikovani električar dok se proizvod koristi sa ili bez transformatora. Naša kompanija neće biti odgovorna za bilo kakva oštećenja koja mogu nastati zbog

korištenja proizvoda bez uzemljenja u skladu s lokalnim propisima.



OPASNOST:

Uređaj mora biti spojen na napojnu mrežu samo od strane ovlaštene i kvalifikovane osobe. Period garancije za proizvod počinje samo nakon ispravno izvršene instalacije. Proizvođač se neće držati odgovornim za oštećenja nastala usljed procedura koje su izvodile neovlaštene osobe.



OPASNOST:

Kabal za napajanje se ne smije pritiskati, savijati ili gnječiti, niti doći u kontakt sa vrućim dijelovima na proizvodu.

Oštećeni kabal za napajanje se mora zamijeniti od strane kvalifikovanog električara. U suprotnom, postoji rizik od elektro šoka, kratkog spoja ili požara!

- Pri spajanju mora se pridržavati državnih propisa.
- Podaci napojnog voda moraju odgovarati podacima navedenim na etiketi o tipu proizvoda. Otvorite prednja vrata da vidite etiketu o tipu.
- Napojni kabal vašeg proizvoda se mora slagati sa vrijednostima iz tabele "Tehničke specifikacije".



OPASNOST:

Prije započinjanja bilo kakvog rada na električnim instalacijama, iskopčajte uređaj iz napajanja.

Postoji rizik od elektro šoka!

Spajanje napojnog kabla



Dok obavljate spajanje žica, morate se pridržavati nacionalnih/lokalnih propisa o električnoj energiji i morate koristiti odgovarajuću utičnicu/vod i utikač za pećnicu. U slučaju da su energetska ograničenja proizvoda izvan trenutnog kapaciteta nosivosti utikača i utičnice/voda, proizvod se mora spojiti direktno preko fiksne električne instalacije, bez korištenja utikača i utičnice/voda.



1. Nije moguće prekinuti sve polove u izvoru napajanja, jedinica prekida s minimalno 3 mm kontaktnog zazoru (osigurači, prekidači linijske sigurnosti, kontaktori) mora biti spojena i svi polovi ove jedinice prekida moraju biti u blizini (ne iznad) proizvoda u skladu sa IEE direktivama. Ne pokoravajte ovim uputstvima može prouzrokovati probleme u radu i učiniti nevažećom garanciju za proizvod.

Preporučuje se dodatna zaštita putem prekidača strujnog kola zaostale električne energije.

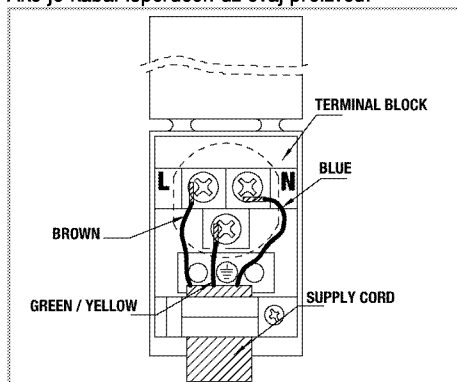
Ako je kabal isporučan uz ovaj proizvod:



2. **Za jednofazno spajanje**, spojite žice kao što je označeno ispod:

- Smeđa/Crna žica = L (Faza)
 - Plava/sed žica = N (Nula)
 - Zeleni/žuti kabal = (E)  (Uzemljenje)
- » ili
- sed/Crna žica = L (Faza)
 - Plava/Smeđa žica = N (Nula)
 - Zeleni/žuti kabal = (E)  (Uzemljenje)

Instalacija proizvoda

1. Gurnite pećnicu u kabinet, poravnajte i pričvrstite je, a s druge strane osigurajte da napojni kabal ne bude prekinut i/ili priklješten.

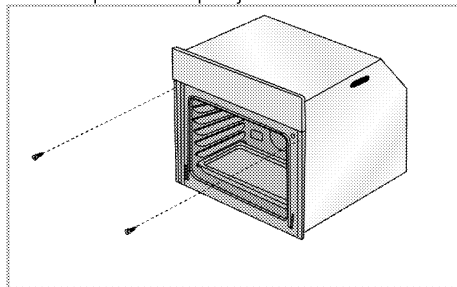

Pričvrstite pećnicu s 2 šarafa kao što je prikazano.

Nakon postavke provjerite jesu li vijci dovoljno zategnuti i da se pećnica ne pomjera. Pećnica se može prevrnuti tokom upotrebe ako nije postavljena prema uputstvima i ako vijci nisu dovoljno zategnuti.

Za proizvode sa ventilatorom za hlađenje (Ona se možda neće nalaziti na vašem proizvodu.)

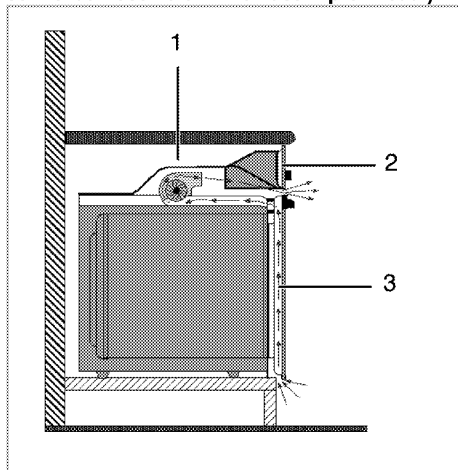

- 1 Ventilator za hlađenje
- 2 Upravljačka ploča
- 3 Vrata

Ugrađeni ventilator hladi ugradbeni kabinet i prednji dio proizvoda.



Ventilator za hlađenje nastavlja s radom tokom 20 - 30 minuta nakon što se pećnica isključi. Ukoliko ste kuhali tako što ste programili programator na pećnici, ventilator za hlađenje će također biti isključen po završetku vremena kuhanja zajedno sa svim ostalim funkcijama

Završna provjera

1. Rukovanje proizvodom.
2. Provjerite funkcije.

Odlaganje starog proizvoda.

- Sačuvajte originalnu kutiju u koju je proizvod bio upakovan i transportujte proizvod u istoj. Slijedite uputstva na kutiji. Ukoliko nemate originalnu kutiju, upakujte proizvod u zaštitnu foliju sa zračnim mjehurićima ili debelu kartonsku ambalažu i čvrsto omotajte ljepljivom trakom.
- Da biste spriječili da žičana polica i pleh oštete vrata pećnice, stavite komad kartona sa unutrašnje strane vrata pećnice, tako da odgovara položaju pleha. Zalijepite trakom vrata pećnice za bočne zidove.
- Ne koristite vrata ili ručku da biste podizali ili premještali ovaj proizvod.



Nemojte stavljati nikakve predmete na proizvod i pomjerajte ga u uspravnom položaju.



Provjerite generalno izgled vašeg proizvoda radi bilo kakvih oštećenja koja su se mogla desiti tokom transporta.

4 Priprema

Savjeti za uštedu energije

Sljedeće informacije će vam pomoći da koristite vaš uređaj na ekološki način i da štedite energiju:



- Koristite emajlirane plehove ili plehove tamne boje u pećnici jer će time biti ostvaren bolji prenos toplote.
- Prilikom pripremanja jela, izvršite operacije prethodnog zagrijavanja ako se to savjetuje u korisničkom priručniku ili uputama za kuhanje.
- Ne otvarajte često vrata pećnice za vrijeme kuhanja.
- Pokušajte istovremeno kuhati (spremati) više od jednog jela u pećnici kad god je to moguće. Možete kuhati tako što ćete staviti dvije posude za kuhanje na rešetku roštilja.
- Spremajte više jela jedno za drugim. Pećnica će već biti vruća.
- Možete uštediti energiju tako što ćete isključiti vašu pećnicu par minuta prije isteka vremena kuhanja. Ne otvarajte vrata pećnice.
- Odmrzните zamrznuta jela prije kuhanja.

Prva upotreba

Podešavanje vremena

 Dok vršite bilo kakva podešavanja, odgovarajući simboli na displeju će treptati.

Nakon što ste prvi put uključili rernu, pritisnite tipke  da podesite vrijeme u toku dana.

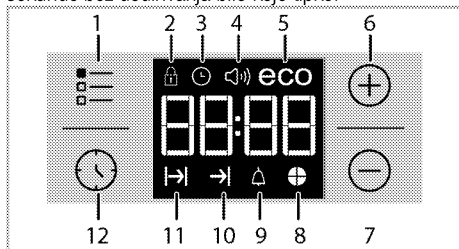

 Za modele s kontrolnom na dodir, prvo  dodirnite i zatim koristite  da biste podesili vrijeme tokom dana.

Potvrdite postavku dodiranjem simbola  i sačekajte 4 sekunde bez dodirivanja bilo koje tipke.



- 1 Tipka za podešavanje
- 2 Simbol zaključane tipke
- 3 Simbol sata

- 4 Simbol jačine alarma (Ona se možda neće nalaziti na vašem proizvodu.)
- 5 Simbol za Eco režim rada
- 6 Tipka plus
- 7 Tipka minus
- 8 Simbol za vrijeme
- 9 Simbol za alarm
- 10 Simbol vremena završetka kuhanja
- 11 Simbol vremena kuhanja
- 12 Taster za program

 Ako inicijalno vrijeme nije podešeno, sat će početi s odbrojavanjem počevši od 12:00 i prikazaće se simbol . Kad vrijeme bude podešeno, taj će simbol nestati.

 Trenutne postavke vremena će se poništiti u slučaju prekida u napajanju. Potrebno ih je ponovo podesiti.

Prvo čišćenje uređaja

 Neki deterdženti i materijali za čišćenje mogu izazvati oštećenja na površini. Nemojte koristiti agresivne deterdžente, praškove/kreme za čišćenje ili bilo kakve oštre predmete dok čistite.

1. Uklonite sve materijale korištene za pakovanje
2. Obrišite površine uređaja vlažnom krpom ili spužvom i posušite krpom.

Početno zagrijavanje

Uključite uređaj da grije nekih 30 minuta i zatim ga isključite. Na taj način, bilo kakvi ostaci proizvodnje ili slojevi će sagorjeti i biti uklonjeni.

UPOZORENJE

 Vruće površine izazivaju opekotine! Uređaj može biti vruć kada se koristi. Nikad nemojte dirati vruće gorionike, unutrašnje dijelove pećnice, grijalice itd. Držite djecu dalje od uređaja. Uvijek koristite rukavice za pećnicu otporne na vrućinu kada stavljate ili uklanjate posude u/iz vrele pećnice.

Električna pećnica

1. Izvadite sve pladnjeve za pečenje i rešetku roštilja van iz pećnice.
2. Zatvorite vrata pećnice.
3. Odaberite položaj Static.

4. Odaberite najveću jačinu roštilja; pogledajte *Kako rukovati električnom pećnicom, Stranica 19.*
5. Pustite pećnicu da radi oko 30 minuta.
6. Isključite vašu pećnicu; Pogledajte *Kako rukovati električnom pećnicom, Stranica 19*

Pećnica sa roštiljom

1. Izvadite sve pladnjeve za pečenje i rešetku roštilja van iz pećnice.
2. Zatvorite vrata pećnice.
3. Odaberite najveću jačinu roštilja; pogledajte *Kako rukovati roštiljom, Stranica 24.*
4. Pustite pećnicu da radi oko 15 minuta.
5. Isključite vašu pećnicu; Pogledajte *Kako rukovati roštiljom, Stranica 24*



Dim i miris mogu se javiti tokom nekoliko sati prilikom inicijalnog puštanja u rad. To je sasvim normalno. Osigurajte da je prostorija dobro ventilirana da bi se uklonio dim i miris. Izbjegavajte direktno inhaliranje dima i mirisa koji se ispušta.

5 Kako rukovati pećnicom

Opće informacije o pečenju, prženju i roštiljanju



UPOZORENJE

Vruće površine izazivaju opekotine! Uređaj može biti vruć kada se koristi. Nikad nemojte dirati vruće gorionike, unutrašnje dijelove pećnice, grijalice itd. Držite djecu dalje od uređaja.

Uvijek koristite rukavice za pećnicu otporne na vrućinu kada stavljate ili uklanjate posuđe u/z vrele pećnice.



OPASNOST:

Vodite računa kada otvarate vrata pećnice jer iz njene unutrašnjosti može izlaziti para. Izlazeća para može prouzrokovati opekotine na vašim rukama, licu i/ili očima.

Savjeti za pečenje

- Koristite odgovarajuće obložene neljepljive metalne ploče i aluminijske posude ili silikonske kalupe otporne na toplotu.
- Maksimalno koristite prostor na polici.
- Postavite kalup za pečenje na srednju policu.
- Odaberite ispravan položaj police prije nego uključite pećnicu ili roštilj. Ne mijenjajte položaj police kada je pećnica vruća.
- Držite vrata pećnice zatvorenim.

Savjeti za prženje

- Treiranje cijelog pileta, ćurke i velikih komada mesa sa začimima poput limunovog soka i crnog bibera prije kuhanja povećati će performanse kuhanja.
- Pečenje mesa s kostima traje oko 15 do 30 minuta duže u poređenju sa prženjem mesa bez kosti iste veličine.
- Svaki centimetar debljine mesa zahtijeva vrijeme kuhanja otprilike 4 do 5 minuta.
- Pustite da meso odstoji u pećnici oko 10 minuta nakon završetka kuhanja. Sok se bolje raspoređuje po cijelom komadu pečenja i ne curi kada se meso siječe.
- Ribu treba staviti na srednju ili donju policu u pladnju otpornom na toplotu.

Savjeti za roštiljanje

Kada se meso, riba i perad pripremaju na roštilju, brzo poprime smeđu boju, imaju finu koru i ne isušuju se. Ravni komadi, mesni ražnjici i kobasice posebno su podesni za roštilj, kao i povrće sa velikom količinom tečnosti kao što su paradajz i crveni luk.

- Rasporedite komadiće koji će se roštiljati na rešetki ili na plehu za pečenje sa rešetkom na takav način da pokriveni prostor ne prelazi veličinu grijaača.
- Gurnite žičanu policu ili pladanj za pečenje sa rešetkom na željeni nivo u pećnicu. Ako roštiljate na žičanoj polici, gurnite pladanj za pečenje na donju policu kako bi se pokupila masnoća. Pladanj za pečenje koji trebate gurnuti mora biti odgovarajuće veličine tako da obuhvata cijelo područje za roštiljanje. Ovaj pladanj možda neće biti isporučen uz proizvod. Dodajte malo vode u pladanj za pečenje radi lakšeg čišćenja.



Hrana koja nije pogodna za roštiljanje nosi sa sobom rizik od požara.

Roštiljajte samo hranu koja je podesna za veliku toplotu prženja. Nemojte stavljati hranu suviše daleko u pozadinu roštilja. To je najtopliji dio pećnice i zamašćena hrana se može zapaliti.

Kako rukovati električnom pećnicom

Odaberite temperaturu i način rada

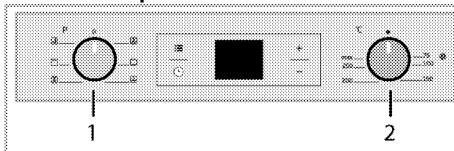

1 Funkcijska sklopka

2 Termostatska sklopka

1. Podesite funkcijsku sklopku na željeni režim rada.
2. Podesite tipku temperature na željenu temperaturu.

» Pećnica se zagrijava do podešene temperature i održava je. Tokom zagrijavanja, lampica temperature ostaje uključena.

Isključivanje električne pećnice

Okrenite funkcijsku sklopku i tipku za temperaturu u položaj isključeno (prema gore).

Važno je pravilno postaviti žičanu rešetku na žičani nosač. Žičana rešetka mora biti umetnuta između nosača kao što je prikazano na slici.

Nemojte dopustiti da žičana rešetka stoji naslonjena na stražnji zid pećnice. Kliznite vašu rešetku na prednji

odjeljak nosača i namjestite je uz pomoć vrata kako biste postigli dobre performanse roštiljanja. (Varira u ovisnosti od modela proizvoda.)

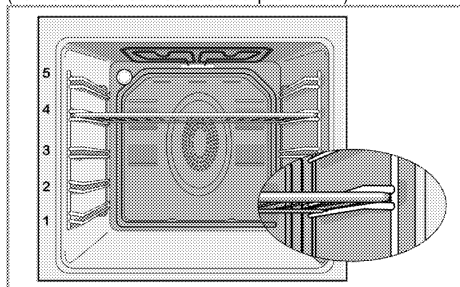

Načini rada

Redoslijed režima rada prikazan ovdje može odstupati od redoslijeda na vašem proizvodu.

Gornje i donje zagrijavanje



Gornje i donje zagrijavanje su u funkciji. Hrana je zagrijana istovremeno s donje i gornje strane. Na primjer, to je pogodno za kolače, tjestenine, ili kolače i kaserole u kalupima za pečenje. Kuhanje samo sa jednim plehom.

Zagrijavanje dna



Samo zagrijavanje donje strane je u funkciji. To je pogodno za pizze i za kasnije rumenjenje hrane s donje strane.



Ova funkcija mora biti korištena za lako čišćenje parom takode.

Zagrijavanje donje/gornje strane potpomognuto ventilatorom



Gornji i donji grijači plus ventilator (u stražnjem zidu) su u funkciji. Vrući zrak je ravnomjerno distribuiran u cijeloj pećnici brzo pomoću ventilatora. Kuhanje samo sa jednim plehom.

Puni roštilj



Veliki roštilj na stropu pećnice je u funkciji. Podesno za roštiljanje velikih količina mesa.

- Stavite velike ili srednje velike porcije na odgovarajuću policu ispod grijača roštilja za roštiljanje.
- Okrenite hranu nakon što protekne polovina vremena roštiljanja.

Roštilj+ventilator



Efekat roštilja nije jak kao kod punog roštilja

- Stavite male ili srednje velike porcije na odgovarajuću policu ispod grijača roštilja za prženje.
- Okrenite hranu nakon što protekne polovina vremena roštiljanja.

"Booster"





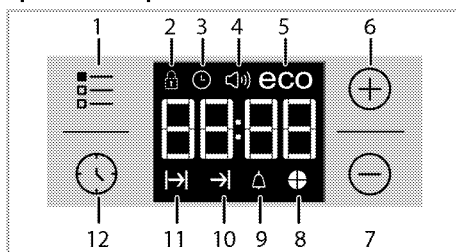

Ova funkcija se koristi za brzo zagrijavanje pećnice; to nije pogodno za kuhanje hrane.

- Odaberite željenu temperaturu nakon odabira ove funkcije. Svjetlo za temperaturu se pali i pećnica je zagrijana.
- Svjetlo se gasi nakon što proces zagrijavanja okonča. Sada odaberite željenu funkciju da kuhate vašu hranu.

Upotreba sata pećnice





- 1 Tipka za podešavanje
- 2 Simbol zaključane tipke
- 3 Simbol sata
- 4 Simbol jačine alarma (Ona se možda neće nalaziti na vašem proizvodu.)
- 5 Simbol za Eco režim rada
- 6 Tipka plus
- 7 Tipka minus
- 8 Simbol za vrijeme
- 9 Simbol za alarm
- 10 Simbol vremena završetka kuhanja
- 11 Simbol vremena kuhanja
- 12 Taster za program

	Maksimalno vrijeme koje može biti podešeno za kraj kuhanja je 5 sata i 59 minuta. Program će biti poništen u slučaju prekida u napajanju. Morate ponovo programirati pećnicu.
	Dok vršite bilo kakva podešavanja, odgovarajući simboli će treptati na displeju. Morate sačekati neko vrijeme da bi postavke postale aktivne.
	Ako nema nikakvih postavki kuhanja, vrijeme u toku dana se ne može podesiti.
	Ako se vrijeme kuhanja postavi kad počnete kuhati, prikazaće se preostalo vrijeme.





Kuhanje pomoću podešavanja vremena kuhanja;



Rernu možete podesiti da prestane s radom na kraju određenog vremena tako što ćete vrijeme kuhanja podesiti na tajmeru.

1. Odaberite funkciju za kuhanje.
2. Dodirnite  dok se simbol  ne pojavi na displeju označavajući vrijeme kuhanja.
3. Podesite vrijeme kuhanja tipkama **+** / **-**.
» » Nakon što podesite vrijeme kuhanja, simbol  i vrijeme rada će se trajno pojaviti na displeju.
4. Stavite jelo u pećnicu i podesite temperaturu pomoću tipke za temperaturu. Kuhanje će početi.
» Vrijeme kuhanja na displeju počinje teći kad kuhanje počne i svijetle svi dijelovi simbola vremena rada. Podešeno vrijeme kuhanja je podijeljeno u 4 jednaka dijela i kad vrijeme svakog dijela isteče, simbol tog dijela se gasi. Tako da je lako shvatiti odnos preostalog vremena kuhanja i ukupnog vremena kuhanja.

Podešavanje kraja vremena kuhanja na kasnije vrijeme;

Nakon podešavanja vremena kuhanja na tajmeru, kraj vremena kuhanja možete podesiti na kasnije vrijeme.

1. Odaberite funkciju za kuhanje.
2. Dodirnite  dok se simbol  ne pojavi na displeju označavajući vrijeme kuhanja.
3. Podesite vrijeme kuhanja tipkama **+** / **-**.
» » Nakon što podesite vrijeme kuhanja, simbol  će se trajno pojaviti na displeju.
4. Dodirnite  dok se simbol  ne pojavi na displeju označavajući kraj vremena kuhanja.
5. Pritisnite tipke **+** / **-** da podesite kraj vremena kuhanja.



» Nakon što podesite vrijeme kuhanja, simbol  plus simbol  i vrijeme rada će se trajno pojaviti na displeju. Kad kuhanje počne, simbol  nestaje.

6. Stavite jelo u pećnicu i podesite temperaturu pomoću tipke za temperaturu. Kuhanje će početi.
» **Programator pećnice računa vrijeme početka oduzimajući vrijeme kuhanja od kraja vremena kuhanja koje ste podesili.** Izabrani način rada se aktivira kad dođe vrijeme za početak kuhanja i pećnica je zagrijana na podešenu temperaturu. Ova temperatura se održava do kraja vremena kuhanja.
» Vrijeme kuhanja na displeju počinje teći kad kuhanje počne i svijetle svi dijelovi simbola vremena rada. Podešeno vrijeme kuhanja je podijeljeno u 4 jednaka dijela i kad vrijeme svakog dijela isteče, simbol tog dijela se gasi. Tako da je lako shvatiti odnos preostalog vremena kuhanja i ukupnog vremena kuhanja.
7. Kad se završi proces kuhanja, na displeju se pojavljuje **"End"** i tajmer šalje zvučno upozorenje.
8. Zvučno upozorenje traje 2 minute. Da prekinete zvučno upozorenje, samo pritisnite bilo koju tipku. Zvučno upozorenje će se utišati i prikazaće se trenutno vrijeme.

 Ako pritisnete bilo koju tipku na kraju zvučnog upozorenja, rerna će ponovo početi s radom. Okrenite dugme za temperaturu i dugme funkcije na položaj **"0"** (isključeno) da isključite rernu da ne bi ponovo počela raditi kad se utiša upozorenje.



Aktiviranje zaključavanja tipki

Aktiviranjem funkcije zaključavanja tipki možete spriječiti mijenjanje zadanih parametara na rerni.

1. Dodirnite  dok se simbol  ne pojavi na displeju.
» Na displeju će se pojaviti **"OFF"**.
2. Pritisnite **+** da biste aktivirali zaključavanje tipki.
» Kada je zaključavanje tipki aktivirano, **"On"** se pojavljuje na displeju, a simbol  ostaje upaljen.

 Tipke pećnice nisu u funkciji kada je aktivirano zaključavanje tipki. Zaključavanje tipki se ne otkažuje u slučaju prekida u napajanju.

Da biste deaktivirali zaključavanje tipki

1. Dodirnite  dok se simbol  ne pojavi na displeju.
» Na displeju će se pojaviti **"On"**.
2. Isključite zaključavanje tipki pritiskom na tipku **-**.
» **"OFF"** će se pojaviti kada je deaktivirano zaključavanje tipki.

Podešavanje sata s alarmom

Osim za programiranje kuhanja, tajmer možete koristiti za bilo koje upozorenje ili podsjetnik.

Sat s alarmom ne utiče na funkcije reme. On se koristi samo kao upozorenje. Na primjer, ovo je korisno kad u određeno vrijeme želite okrenuti hranu u rerni. Tajmer će vam poslati zvučno upozorenje na kraju podešenog vremena.

1. Dodirnite  dok se simbol  ne pojavi na displeju.





Maksimalno vrijeme alarma može biti 23 sata i 59 minuta.

2. Podesite vrijeme trajanja alarma tako što ćete koristiti tipke **+/-**.



Funkcijske tipke za ton alarma, vrijeme u toku dana, svjetlina ekrana i tipke za temperaturu bi trebale biti u položaju 0 (SKLJ.).

» Kad je vrijeme alarma podešeno, simbol  će ostati upaljen i vrijeme alarma će se pojaviti na displeju.



3. Kad istekne vrijeme alarma, simbol  počinje treperiti i oglašava se zvučno upozorenje.

Isključivanje alarma

1. Zvučno upozorenje traje 2 minute. Da prekinete zvučno upozorenje, samo pritisnite bilo koju tipku.

» Zvučno upozorenje će se utišati i prikazaće se trenutno vrijeme.

Otkazivanje alarma;



1. Da isključite alarm, dodirnite  dok se simbol  ne pojavi na displeju.

2. Pritisnite i držite tipku **■** dok se ne prikaže "00:00".



Prikazaće se vrijeme alarma. Ako su vrijeme alarma i vrijeme kuhanja podešeni istovremeno, prikazaće se kraće vrijeme.

Promjena tona alarma

1. Dodirnite  dok se simbol  ne pojavi na displeju.



2. Podesite željeni ton alarma s tipkama **+ / ■**.

3. Podešeni ton će se aktivirati za kratko vrijeme.

» Izabrani ton alarma biće prikazan kao "b-01", "b-02" ili "b-03" na displeju.

Mijenjanje vremena tokom dana

Da promijenite vrijeme tokom dana koje ste ranije podesili:

1. Dodirnite  dok se simbol  ne pojavi na displeju.

2. Podesite vrijeme tokom dana s tipkama **+ / ■**.

3. Vrijeme koje ste podesili će se aktivirati za kratko vrijeme.

Ekonomični režim rada

Ekonomičnim režimom rada možete uštediti energiju dok kuhate tako što ćete podesiti vrijeme kuhanja u remi.

Isključivanjem grijača prije kraja vremena kuhanja, ovaj režim završava kuhanje s unutrašnjom temperaturom reme.

Podešavanje ekonomičnog režima rada

1. Dodirnite simbol  dok se simbol **eco** ne pojavi na displeju.

» Na displeju će se pojaviti "OFF".

2. Uključite ekonomični režim rada dodirom tipke **+**.

» Kada je zaključavanje tipki aktivirano, "On" se pojavljuje na displeju, a simbol eco ostaje upaljen.

Isključivanje ekonomičnog režima rada

1. Dodirnite simbol  dok se simbol **eco** ne pojavi na displeju.

» Na displeju će se pojaviti "On".

2. Isključite ekonomični režim rada dodirom tipke **■**.

» "Off" će se pojaviti kad je deaktivirano zaključavanje tipki.

Podešavanje osvjetljenja ekrana

(Ova funkcija je opcionalna. Ona se možda neće nalaziti na vašem proizvodu.)

1. Dodirnite  dok se **d-01** ili **d-02** ili **d-03** ne pojavi na displeju označavajući osvjetljenje displeja.

2. Podesite željeno osvjetljenje s tipkama **+ / ■**.

» Vrijeme koje ste podesili će se aktivirati za kratko vrijeme.

Tabela vremena kuhanja



Vremena u ovoj karti služe kao vodič. Vremena mogu varirati zbog temperature hrane, debljine, vrste i vaših vlastitih preferencija u vezi kuhanja.

Pečenje i prženje



1. polica pećnice je donjapolica.

Posuda	Broj pladnjeva	Dodatna oprema za korištenje	Način rada	Položaj police	Temperatura (°C)	Vrijeme kuhanja (približno u min.)
Kolači u plehu	Jedan pladanj	Standardni pladanj*		3	180	25 ... 30
Kolači u kalupu	Jedan pladanj	Kalup za tortu na rešetci roštilja**		2	180	40 ... 50
Mali kolači	Jedan pladanj	Standardni pladanj*		3	160	25 ... 35
Biskvit kolač	Jedan pladanj	Okrugla opružna tava prečnika 26 cm na rešetci roštilja**		3	160	25 ... 35
Kolači	Jedan pladanj	Pladanj za tijesto*		3	180	25 ... 30
Kolači od tijesta	Jedan pladanj	Standardni pladanj*		2	200	30 ... 40
Filovana tjestenina	Jedan pladanj	Standardni pladanj*		2	200	25 ... 35
Kvasac	Jedan pladanj	Standardni pladanj*		2	200	35 ... 45
Lazanje	Jedan pladanj	Staklena/metalna pravougaona tava na rešetci roštilja**		2 - 3	200	30 ... 40
Pizza	Jedan pladanj	Standardni pladanj*		2	200 ... 220	15 ... 20
Govedi odrezak (cijel) / pržen	Jedan pladanj	Standardni pladanj*		3	25 min. 250/max, zatim 180 ... 190	100 ... 120
Janjeći but (lonac)	Jedan pladanj	Standardni pladanj*		3	25 min. 220 zatim 180 ... 190	70 ... 90
Pileće pečenje (1,8-2 kg)	Jedan pladanj	Standardni pladanj*		2	15 min. 250/max, zatim 180 ... 190	60 ... 80
Čurka (5.5 kg)	Jedan pladanj	Standardni pladanj*		1	25 min. 250/max, zatim 180 ... 190	150 ... 210
Riba	Jedan pladanj	Standardni pladanj*		3	200	20 ... 30

Preporučuje se prethodno zagrijavanje za sve vrste hrane.
 * Moguće je da ovaj dodatni pribor ne bude isporučen s proizvodom.
 ** Ovaj dodatni pribor nije isporučen s proizvodom. Ovaj dodatni pribor je komercijalno dostupan.

Tabela kuhanja za testiranje jela

Jela u ovoj tabeli kuhanja su pripremljena u skladu sa EN 60350-1 kako bi se omogućilo kontrolnim institucijama da testiraju proizvode

Posuda	Broj pladnjeva	Dodatna oprema za korištenje	Način rada	Položaj police	Temperatura (°C)	Vrijeme kuhanja (približno u min.)
Shortbread	Jedan pladanj	Standardni pladanj*		3	140	20 ... 30
Mali kolači	Jedan pladanj	Standardni pladanj*		3	160	25 ... 35
Biskvit kolač	Jedan pladanj	Okrugla opružna tava prečnika 26 cm na rešetci roštilja**		3	160	25 ... 35
Pita s jabukama	Jedan pladanj	Okrugla crna metalna posuda prečnika 20 cm na rešetci roštilja**		2	180	50 ... 60

Preporučuje se prethodno zagrijavanje za sve vrste hrane.
 * Moguće je da ovaj dodatni pribor ne bude isporučen s proizvodom.
 ** Ovaj dodatni pribor nije isporučen s proizvodom. Ovaj dodatni pribor je komercijalno dostupan.

Upute za pečenje kolača

- Ako je kolač previše suh, povećajte temperaturu za nekih 10 i smanjite vrijeme kuhanja.
- Ako je kolač vlažan, koristite manje tečnosti ili snizite temperaturu za 10 .
- Ako je kolač previše taman na vrhu, postavite ga na nižu policu, snizite temperaturu i povećajte vrijeme kuhanja.
- Ako je skuhanu dobro s unutrašnje strane ali je gnjecavo s vanjske strane koristite manje tečnosti, snizite temperaturu i povećajte vrijeme kuhanja.

Upute za pečenje tijesta

- Ako je kolač previše suh, povećajte temperaturu za nekih 10 i smanjite vrijeme kuhanja. Navlažite slojeve tijesta sosom od mlijeka, ulja, jaja i jogurta.
- Ako traje predugo da se kolač ispeče, pobrinute se da debljina tijesta koje ste pripremili ne premašuje dubinu pleha.
- Ako je gornja strana kolača postala braonkasta, ali donja strana još nije kuhana, uvjerite se da količina sosa koji se upotrijebili za kolač nije prevelika na dnu kolača. Pokušajte ravnomjerno rasporediti sos između i po slojevima tijesta kako bi ravnomjerno porumenili.



Pecite tijesto u skladu sa režimom rada i temperaturom koji su dati u tabeli kuhanja. Ako donji dio još nije dovoljno rumen, slijedeći put ga stavite na jednu policu niže.

Uputstva za kuhanje povrća

- Ako jelo od povrća ostaje bez sokova i postaje previše suho, kuhajte ga u tavi sa poklopcem umjesto u plehu. Zatvorene posude će sačuvati sokove koje daje jelo.
- Ako se jelo od povrća ne skuha, prokuhajte povrće unaprijed ili ga pripremite kao konzerviranu hranu i stavite u pećnicu.

Kako rukovati roštiljom



UPOZORENJE

Zatvorite vrata pećnice tokom pečenja na roštilju.

Vruće površine mogu izazvati opekotine!

Uključivanje roštilja

1. Okrenite funkcijski sklopku do željenog simbola roštilja.
2. Zatim odaberite željenu temperaturu roštilja.
3. Ako je potrebno, uradite prethodno zagrijavanje oko 5 minuta.

» Lampica temperature se pali.

Isključivanje roštilja

1. Okrenite funkcijsku sklopku u položaj Off (isključeno) (prema gore).



Hrana koja nije pogodna za roštiljanje nosi sa sobom rizik od požara.

Roštiljajte samo hranu koja je podesna za veliku toplotu prženja.

Nemojte stavljati hranu suviše daleko u pozadinu roštilja. To je najtopliji dio pećnice i zamašćena hrana se može zapaliti.

Vrijeme pripremanja hrane korištenjem funkcije roštilja

Roštiljanje električnim roštiljom

Hrana	Dodatna oprema za korištenje	Položaj police	Preporučena temperatura (°C)**	Vrijeme roštiljanja (približno)
Riba	Rešetka roštilja	4..5	250	20...25 min. #
Pileći odrezak	Rešetka roštilja	4..5	250	25...35 min.
Sjeckana janjetina	Rešetka roštilja	4..5	250	20...25 min.
Govede pečenje	Rešetka roštilja	4..5	250	25...30 min. #
Sjeckana teletina	Rešetka roštilja	4..5	250	25...30 min. #
Tost *	Rešetka roštilja	4	250	1...3 min.

ovisno o debljini

*Prethodno zagrijati tokom 5 minuta

**Ako se temperatura roštilja vašeg proizvoda ne može podesiti, roštilj će raditi na preporučenoj temperaturi.

Jela u ovoj tabeli kuhanja su pripremljena u skladu sa EN 60350-1 kako bi se omogućilo kontrolnim institucijama da testiraju proizvode

Hrana	Dodatna oprema za korištenje	Položaj police	Temperatura (°C)	Vrijeme kuhanja (približno u min.)
Tost	Rešetka roštilja	4	250	1...3 min.
Čufte (govedina) - 12 komadi	Rešetka roštilja	4	250	25...35 min.

Okrenite hranu nakon 2/3 ukupnog vremena roštiljanja.

Preporučuje se prethodno zagrijavanje od 5 minuta za prženje svake vrste hrane.

6 Održavanje i njega

Opšte informacije

Životni vijek proizvoda će biti produžen, a učestali problemi će se smanjiti ukoliko se proizvod čisti u redovnim intervalima.

**OPASNOST:**

Isključite uređaj s glavnog napajanja prije započinjanja aktivnosti oko održavanja i čišćenja.

Postoji rizik od elektro šoka!

**OPASNOST:**

Sačekajte da se uređaj ohladi prije čišćenja. Vruće površine mogu izazvati opekotine!

- Očistite temeljito proizvod nakon svake upotrebe. Na taj način će biti moguće lakše uklanjanje ostataka kuhanja, te oni neće gorjeti prilikom narednog korištenja uređaja.
- Za čišćenje uređaja nisu potrebna posebna sredstva za čišćenje. Koristite toplu vodu s tečnošću za pranje, mekanu krpu ili spužvu da očistite proizvod i zatim ga prebrišete suhom krpom.
- Uvijek osigurajte da bilo kakav višak tečnosti bude temeljito obrisano nakon čišćenja i sve što je proljeveno da se odmah posuši brisanjem.
- Nemojte koristiti sredstva za čišćenje koja sadrže kiseline ili hlorid da biste čistili površine od nehrđajućeg materijala ili od inoksa niži za čišćenje ručke. Koristite mekanu krpu sa tečnim deterdžentom (ne abrazivnim) da prebrišete te dijelove, obratite pažnju da brišete u jednom smjeru.



Neki deterdženti i materijali za čišćenje mogu izazvati oštećenja na površini.

Nemojte koristiti agresivne deterdžente, praškove/kreme za čišćenje ili bilo kakve oštre predmete dok čistite.



Nemojte koristiti čistače na paru da čistite uređaj jer bi to moglo prouzrokovati strujni udar.

Čišćenje kontrolne ploče

Očistite kontrolnu ploču i kontrolne tipke vlažnom krpom te ih potom osušite.



Ako je proizvod opremljen dugmadima/tipkama, nemojte uklanjati kontrolnu dugmad da čistite kontrolnu tablu. Kontrolna tabla bi se mogla oštetiti!

Čišćenje pećnice

Čišćenje bočnih zidova (Varira u ovisnosti od modela proizvoda.)

(Ova funkcija je opcionalna. Ona se možda neće nalaziti na vašem proizvodu.)

1. Uklonite prednji dio bočnog nosača tako što ćete ga povući u smjeru suprotnom od bočnog zida.
2. Uklonite bočni nosač u potpunosti tako što ćete ga povući prema sebi.

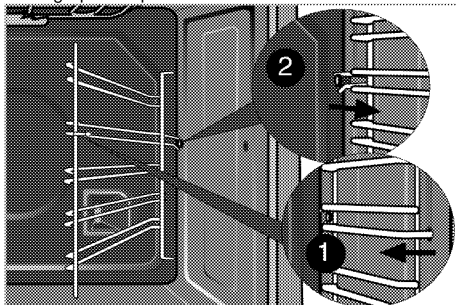

Katalitički zidovi

(Ova funkcija je opcionalna. Ona se možda neće nalaziti na vašem proizvodu.)

Unutrašnji bočni zidovi (A) i/ili stražnji zid (B) vašeg proizvoda mogu biti obloženi katalitičkim emajlom. Katalitički zidovi imaju svijetlu mat boju i poroznu površinu. Katalitički zidovi pećnice se ne trebaju čistiti. Zahvaljujući svojoj perforiranoj strukturi, katalitičke površine apsorbiraju mast i kad se površina ispuni mašću, počinju sjajiti. U ovom slučaju preporučuje se zamjena dijelova.

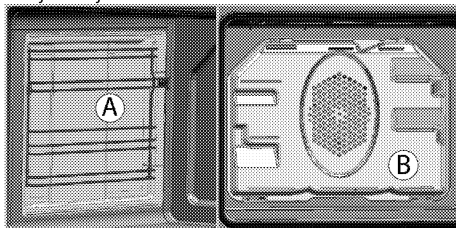

Lako čišćenje parom

To osigurava lako čišćenje jer se prljavština (bez predugog čekanja) omekša pomoću pare koja se formira unutar pećnice i vodenih kapljica koje se kondenzuju na unutrašnjim površinama pećnice.

1. Uklonite sav pribor iz pećnice.
2. Ulijte 500 ml vode u pladanj pećnice i postavite pladanj na 2. policu u pećnici.

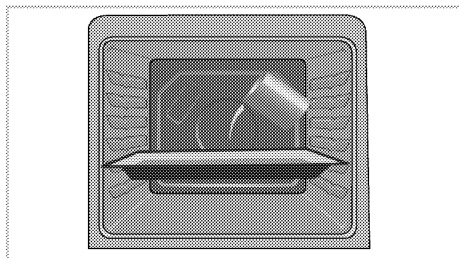

3. Postavite pećnicu na jednostavan način rada čišćenje parom i rade na 100 ° C 25 minuta.
4. Otvorite vrata i obrišite unutrašnje površine u pećnici sa vlažnom spužvom ili krpom.
5. Koristite toplu vodu s tečnošću za pranje, mekanu krpu ili spužvu da očistite postoja na zaprljanja i zatim prebrišite suhom krpom.



U toku režima laganog čišćenja pomoću pare, voda se postavlja u pladanj tako da se ostaci/prljavština u unutrašnjosti pećnice isparavaju i kondenzuju u šupljinu pećnice i unutrašnje staklo pećnice, tako da voda može da kaplje kada je vrata pećnice otvorena. Obrišite kondenzaciju čim se vrata pećnice otvore.

Čišćenje vrata pećnice

Da biste očistili vrata pećnice, koristite toplu vodu s tečnošću za pranje, mekanu krpu ili spužvu da očistite proizvod i zatim prebrišite suhom krpom.



Nemojte koristiti bilo kakva gruba abrazivna sredstva za čišćenje ili oštre metalne strugače za čišćenje vrata pećnice. Njima se može izgrebati površina i uništiti staklo.

Skidanje vrata pećnice

1. Otvorite prednja vrata (1).
2. Otvorite spojnice na kućištu šarke (2) na desnoj i lijevoj strani prednjih vrata tako što ćete ih pritisnuti prema dolje kako je prikazano na slici.

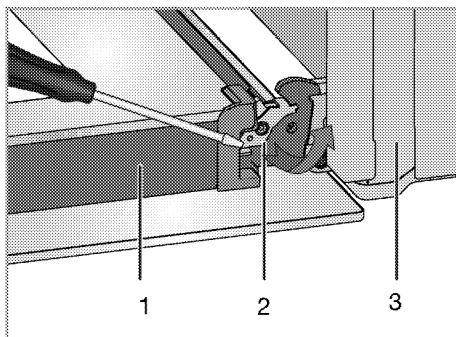

- 1 Vrata
- 2 Zaključavanje šarke(zatvorena pozicija)
- 3 Pećnica
- 4 Zaključavanje šarke(otvorena pozicija)

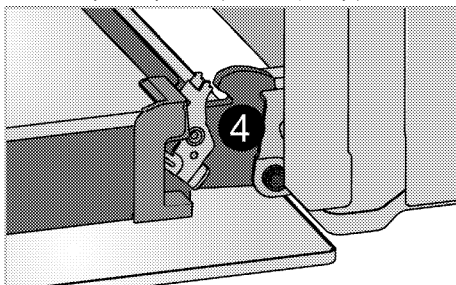

3. Pomjerite prednja vrata do polovine.

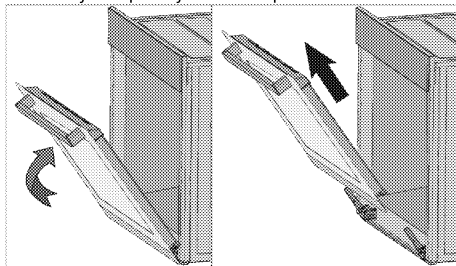

4. Uklonite prednja vrata povlačenjem prema gore kako biste ih oslobodili veze sa šarkama na lijevoj i desnoj strani.



Koraci koje ste izvodili prilikom procesa skidanja trebali bi biti ponovljeni obrnutim redoslijedom kada sklapate vrata. Nemojte zaboraviti zatvoriti spojnice na kućištu šarki prilikom postavljanja vrata.

Uklanjanje unutrašnjeg stakla na vratima

(Ova funkcija je opcionalna. Ona se možda neće nalaziti na vašem proizvodu.)

Unutrašnja staklena ploča na vratima pećnice može se skinuti radi čišćenja.

1. Otvorite vrata pećnice.

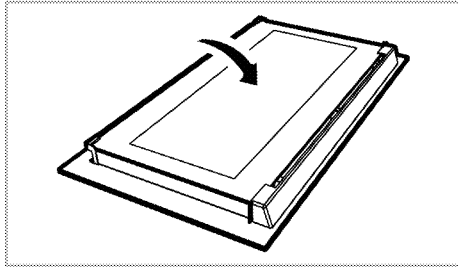

2. Povucite prema sebi i uklonite plastični dio postavljen na gornjem odjeljku prednjih vrata.

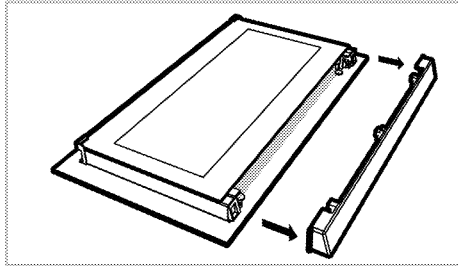

3. Kao što je prikazano na slici, lagano podignite najskrovitiju staklenu ploču (1) u smjeru A i povucite je van u smjeru B.

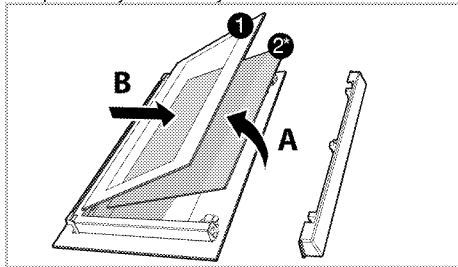

1. Najskrovitija (unutrašnja) staklena ploča
- 2* Unutrašnja staklena ploča (Ona se možda neće nalaziti na vašem proizvodu.)
4. Ako je vaš proizvod opremljen unutrašnjom staklenom pločom (2); ponovite istu proceduru za uklanjanje unutrašnje staklene ploče (2).
5. Prvi korak da se ponovo sklope vrata jeste postavljanje unutrašnje staklene ploče (2). postavite zarubljeni ugao staklene ploče tako da

ostane u zarubljenom uglu plastičnog proreza. (Ako je vaš proizvod opremljen unutrašnjom staklenom pločom). Unutrašnja staklena ploča (2) mora biti postavljena u plastični prorez u blizini najskrovitije staklene ploče (1).

6. Kada postavljate najskrovitiju staklenu ploču (1), budite sigurni da ispisana strana ploče bude okrenuta prema unutrašnjoj staklenoj ploči. Važno je da se donji ugao najskrovitija (unutrašnja) staklena ploče (1) smjesti u donji plastični prorez.
7. Gurajte plastični dio prema okviru dok ne čujete zvuk "klik".

Zamjena svjetla u pećnici



OPASNOST:

Prije zamjene sijalice u pećnici, budite sigurni da je uređaj isključen iz elektro mreže i ohlađen kako biste izbjegli rizik od elektro šoka.

Vruće površine mogu izazvati opekotine!



U ovoj pećnici koristi se žarulja sa žarnom niti snage manje od 40 W, visine manje od 60 mm, promjera manje od 30 mm ili halogena lampa sa utičnicom tipa G9, snage manje od 60 W. Svjetiljke su pogodne za rad na temperaturama iznad 300 ° C. Lampae za pećnicu možete nabaviti od ovlaštenog servisera ili tehničara sa licencom.



Pozicija lampice može biti drugačija od one prikazane na slici.



Lampica koja se koristi u ovom uređaju nije pogodna za osvijetljavanje prostorija u domaćinstvu. Namijenjena upotreba za ovu lampicu je da pomogne korisniku da vidi namirnice.



Lampice koje se koriste u ovom uređaju moraju podnositi ekstremne fizičke uslove kao što su temperature iznad 50°C.

Ukoliko je vaša pećnica opremljena okruglom lampicom:

1. Iskopčajte proizvod sa napajanja.
2. Okrenite stakleni poklopac u smjeru suprotnom od smjera kretanja kazaljke na satu kako biste ga skinuli.

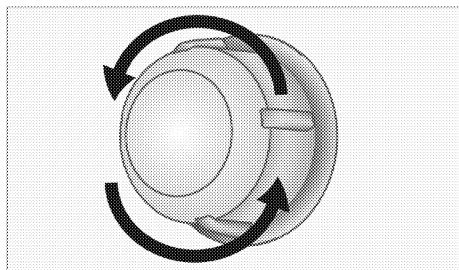

3. Ako je lampica vaše pećnice tipa (A), kako je prikazano na slici u nastavku, izvadite je tako što ćete je rotirati kao što je prikazano i zamijenite je. Ako je lampica tipa (B), povucite je i izvadite kao što je prikazano na slici i zamijenite je.

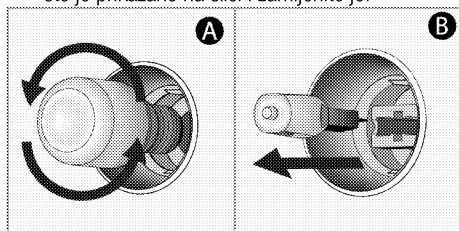

4. Vratite stakleni poklopac na mjesto.

7 Rješavanje problema

Pećnica ispušta paru kada je u upotrebi.

- Uobičajeno je da tokom rada iz uređaja izlazi para. >>> *Nije riječ o kvaru.*

Proizvod odašilje metalne zvukove dok se zagrijava i hladi.

- Kada se metalni dijelovi zagrijavaju, mogu se širiti i praviti zvukove. >>> *Nije riječ o kvaru.*

Proizvod ne radi.

- Osigurač napajanja je pokvaren ili je pregorio. >>> *Provjerite osigurače u kutiji s osiguračima. Ako je potrebno, zamijenite ih ili vratite u početni položaj.*
- Proizvod nije uključen u (uzemljen) utičnicu. >>> *Provjerite utikač na kabl.*

Svjetlo u pećnici ne radi.

- Sijalica u pećnici je pokvarena. >>> *Zamijenite sijalicu u pećnici.*
- Napajanje je prekinuto. >>> *Provjerite da li ima napajanja. Provjerite osigurače u kutiji s osiguračima. Ako je potrebno, zamijenite ih ili vratite u početni položaj.*

Pećnica se ne zagrijava.

- Funkcija i/ili temperatura nisu podešene. >>> *Podesite funkciju i temperaturu pomoću sklopke/tipke za odabir funkcije ili temperature.*
- Kod modea koji su opremljeni programatorom, programator nije podešen. >>> *Podesite vrijeme.* (Kod proizvoda sa mikrovalnom pećnicom, programator upravlja samo mikrovalnom pećnicom.)
- Napajanje je prekinuto. >>> *Provjerite da li ima napajanja. Provjerite osigurače u kutiji s osiguračima. Ako je potrebno, zamijenite ih ili vratite u početni položaj.*

(Kod modela sa programatorom) ekran sata trepće ili simbol sata svjetli.

- Ranije se dogodilo prekid u napajanju. >>> *Podesite vrijeme / isključite proizvod i zatim ga ponovo uključite.*



Ukoliko ne možete ukloniti problem čak i ako ste implementirali uputstva iz ovog odjeljka, posavjetujte se sa ovlaštenim serviserom ili trgovcem kod kojeg ste kupili vaš proizvod. Nikada ne pokušavajte sami popravljati neispravan proizvod.

beko

Sisseehitatav ahi

Kasutusjuhend

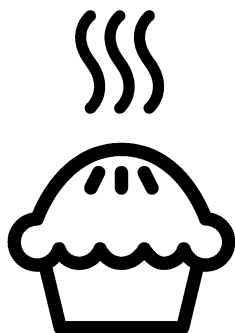

ET

Tutvuge palun esmalt käesoleva kasutusjuhendiga!

Lugupeetud klient!

Aitäh, et otsustasite Bekou toote kasuks. Loodetavasti jääte selle kaasaegse tehnoloogia järgi valmistatud kvaliteetse toote tööga rahule. Selleks tutvuge enne toote kasutamist hoolikalt kasutusjuhendi ja kõigi kaasasolevate dokumentidega ja hoidke need alles. Kui annate toote üle uuele omanikule, pange kaasa ka kasutusjuhend. Järgige kõiki kasutusjuhendis toodud hoiatusi ja juhiseid.

Pidage meeles, et kasutusjuhendis võib olla juttu mitmest mudelist. Mudelite erinevused on kasutusjuhendis välja toodud.

Sümbolite tähendused

Kasutusjuhendis kasutatakse järgmisi sümboleid:

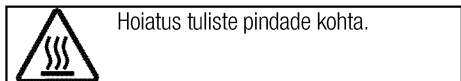
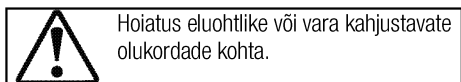
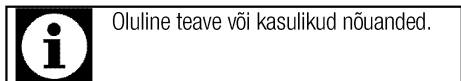

Arçelik A.Ş.
Karaağaç caddesi No:2-6
34445 Sütlüce/Istanbul/TURKEY
Made in TURKEY

**1 Olulised hoiatused ning juhised
ohutuse tagamiseks ja keskkonna
säätmiseks 4**

Üldine ohutus	4
Elektriohutus	4
Toote ohutu kasutamine	5
Ettenähtud otstarve	7
Laste ohutuse tagamine	7
Toote kõrvaldamine kasutuselt	7
Pakkematerjali kõrvaldamine	8

2 Üldine teave 9

Ülevaade	9
Pakendi sisu	10
Tehnilised andmed	11

3 Paigaldamine 12

Enne paigaldamist	12
Paigaldamine ja ühendamine	14
Toote kõrvaldamine kasutuselt	16

4 Ettevalmistused 17

Nõuandeid energia säästmiseks	17
Esimene kasutuskord	17

Kellaaja sisestamine	17
Seadme esmane puhastamine	17
Esmane kuumatamine	17

5 Kuidas ahju kasutada 19

Üldine teave küpsetamise, röstimise ja grillimise kohta	19
Elektriahju kasutamine	19
Töörežiimid	20
Ahju kella kasutamine	20
Küpsetusaegade tabel	22
Kuidas grilli kasutada	24
Küpsetamisaegade tabel grillimiseks	24

6 Hoidmine ja hooldus 25

Üldine teave	25
Juhtpaneeli puhastamine	25
Ahju puhastamine	25
Ahjuukse eemaldamine	26
Ukse siseklaasi eemaldamine	26
Ahjuvalgusti piri vahetamine	27

7 Probleemide lahendamine 28

1 Olulised hoiatused ning juhised ohutuse tagamiseks ja keskkonna säästmiseks

Käesolev peatükk sisaldab ohutusjuhiseid, mis aitavad teil vältida kehavigastusi ja varalist kahju. Nende juhiste eiramisel kaotab garantii kehtivuse.

Üldine ohutus

- Üle 8-aastased lapsed ja füüsilise, meelevõi vaimupuudega inimesed või isikud, kellel puuduvad vastavad kogemused või teadmised, võivad seadet kasutada juhul, kui nad teevad seda järelevalve all või on saanud seadme kasutamiseks vajalikud juhised ning mõistavad sellega kaasnevaid ohte.

Lapsed ei tohi seadmega mängida. Lapsed ei tohi omapead seadet puhastada ja hooldada.

- Seadet ei tohi kasutada lapsed ega füüsilise, meelevõi vaimse puudega isikud või kogemusteta ja vastavate teadmisteta isikud, kui nad ei tegutse nende ohutuse eest vastutava isiku järelevalve või juhendamise all.

Lapsed ei tohi seadmega mängida, kui puudub järelevalve.

- Kui toode antakse kellelegi teisele isiklikuks kasutamiseks või uuele omanikule, tuleb anda kaasa ka kasutusjuhend, toote etiketid ja

muud olulised dokumendid ja osad.

- Paigaldus- ja remonttööd tuleb alati jätta volitatud teeninduse hooleks. Tootja ei vastuta kahjude eest, mis tulenevad volitamatu isikute tehtud protseduuridest ja võivad muuta garantii kehtetuks. Enne paigaldamist tutvuge hoolikalt juhistega.
- Ärge kasutage toodet, kui see on rikkis või sellel on nähtavaid vigastusi.
- Kontrollige pärast iga kasutuskorda, et toote funktsiooninupud on välja lülitatud.

Elektriohutus

- Rikkis toodet ei tohi kasutada, vaid see tuleb lasta volitatud teeninduses korda teha. Elektrilöögi oht!
- Toote võib ühendada ainult maandatud elektrikontakti/-liiniga, mille pinge ja kaitse vastavad tabelile "Tehnilised andmed". Laske maandus paigaldada kvalifitseeritud elektrikul olenemata sellest, kas kasutate toodet transformaatoriga või ilma. Meie ettevõtte ei vastuta probleemide eest, mis on tingitud toote kasutamisest ilma

- kohalikele eeskirjadele vastava maanduseta.
- Ärge kunagi peske toodet veega uhtudes või üle kallates!
Elektrilöögi oht!
 - Paigaldamise, hoolduse, puhastamise ja remondi ajaks tuleb toode vooluvõrgust lahutada.
 - Kui toote toitejuhe saab viga, peab tootja, hooldusfirma või vastava kvalifikatsiooniga elektrik ohu vältimiseks selle välja vahetama.
 - Seade tuleb paigaldada nii, et selle saab võrgust täielikult lahti ühendada. Lahtiühendamise võimalus tuleb tagada voolupistikuga või püsielektrisüsteemi paigaldatud lülitiga, mis vastab ehitusnõuetele.
 - Kasutamisel ahju tagakülg kuumeneb. Veenduge, et elektrijuhtmed ei puutu vastu ahju tagakülge, sest kuumus võib neid kahjustada.
 - Ärge muljuge toitejuhet ahjuukse ja korpuse vahele ja ärge asetage seda tuliste pindade peale. Juhtme isolatsioon võib sulada ning lühise tõttu võib tekkida tulekahju.
 - Elektriseadmetel ja -süsteemidel peaksid töid teostama ainult volitatud ja vastava kvalifikatsiooniga isikud.
 - Kahjustuste tekkimisel lülitage toode välja ning lahutage see vooluvõrgust. Selleks lülitage välja kaitsekork.
 - Veenduge, et kaitsme voolutugevus vastab toote niminäitajatele.
- Toote ohutu kasutamine**
- HOIATUS: Seade ja selle välispinnad muutuvad kasutamise käigus tuliseks. Kindlasti tuleb hoiduda kokkupuutest kuumutuselementidega. Alla 8-aastased lapsed tuleb seadmest eemal hoida, välja arvatud juhul, kui nad on täiskasvanu pideva jälgimise all.
 - Ärge kasutage toodet, kui mõtlemisvõime või koordinatsioon on alkoholi ja/või uimastite tarbimise tagajärjel halvenenud.
 - Olge toitudesse alkohoolseid jooke lisades ettevaatlik. Kõrgel temperatuuril alkohol aurustub ning võib tuliste pindadega kokku puutudes põhjustada tulekahju.
 - Ärge asetage toote lähedusse kergestisüttivaid materjale, kuna selle küljed võivad kasutamise ajal kuumeneda.
 - Kasutamise käigus seade kuumeneb. Kindlasti tuleb hoiduda kokkupuutest ahju sees paiknevate kuumutuselementidega.

- Ärge tõkestage ventilatsioonivahendeid.
- Ärge kuumutage ahjus suletud konservikarpe ja klaaspurke. Purgis tekkida võiva surve tagajärjel võib see lõhkeda.
- Ärge asetage küpsetusplaate, nõusid või fooliumit ahju põhja. Kogunev kuumus võib ahju põhja kahjustada.
- Ärge kasutage ahju ukseklaasi puhastamiseks tugevatoimelisi abrasiivseid puhastusvahendeid ega teravaid metallkraabitsaid, sest need võivad pinda kriimustada ning põhjustada klaasi purunemise.
- Ärge kasutage puhastamiseks aurupuhasteid, muidu võite saada elektrilöögi.
- (Varieerub olenevalt toote mudelist.)
Traatrest ja ahjuplaadi asetamine siinidele
Traatrest ja/või ahjuplaat tuleb kindlasti asetada siinidele õigesti. Lükake traatrest või küpsetusplaat kahe siini vahele ja enne sellele toidu asetamist veenduge, et see püsib kindlalt paigas (vt allolevat joonist).

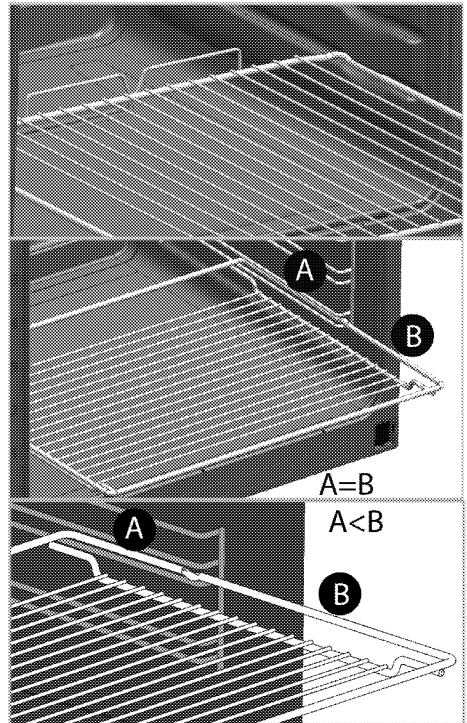

- Ärge kasutage toodet, kui selle esiukse klaas on eemaldatud või mõranenud.
- Toitu kuuma ahju pannes või välja võttes kasutage alati kuumuskindlaid pajakindaid.
- Katke pann või ahjutarvik (nt plaat või rest) küpsetuspaberiga, asetage selle peale toit ning pange kõik eelsoojendatud ahju. Üle ahjutarviku või panni ääre ulatuv küpsetuspaber tuleb eemaldada, et see ei puutuks kütteelementidega kokku. Ärge kunagi kasutage küpsetuspaberit küpsetuspaberi jaoks ettenähtud temperatuurist kõrgemal temperatuuril. Ärge kunagi

asetage küpsetuspaberit vahetult ahjupõhjale.

- HOIATUS: Enne lambipirni vahetamist veenduge, et seadme toitejuhe on pistikust eemaldatud või seade on välja lülitatud - muidu võite saada elektrilöögi.
- Ülekuumenemise vältimiseks ei tohi seadet paigaldada dekoratiivse ukse taha.

Toote tuleohutuse tagamine:

- Veenduge, et pistik on kindlalt pesas, et ei tekiks sädemeid.
- Ärge kasutage kahjustatud või vigastatud juhet. Samuti ei tohi kasutada pikendusjuhet.
- Vältige niiskuse või vedeliku sattumist toote ühendamiseks kasutatud pistikupesale.

Ettenähtud otstarve

- Toode on mõeldud ainult kodukasutuseks. Kasutamine ettevõtluses ei ole lubatud.
- TÄHELEPANU: Seade on mõeldud ainult toidu valmistamiseks. Seda ei tohi kasutada muuks otstarbeks, näiteks ruumi kütmiseks.
- Toodet ei tohi kasutada taldrikute soojendamiseks grillielemendi all, käterätikute ja nõudepesulappide vms kuivatamiseks (riputades need käepidemete külge) ja kütmiseks.
- Tootja ei võta mingit vastutust ebaõige kasutamise või

käsitsemise tagajärjel tekkinud kahjude eest.

- Ahju võib kasutada toidu sulatamiseks, küpsetamiseks, hautamiseks ja grillimiseks.

Laste ohutuse tagamine

- HOIATUS: Ligipääsetavad osad võivad kasutamisel kuumeneda. Väikelapsed tuleb eemal hoida.
- Pakkematerjalid on lastele ohtlikud. Hoidke pakkematerjale väljaspool laste käeulatus. Käidelge kõiki pakendijäätmeid vastavalt keskkonnastandarditele.
- Elektriseadmed on lastele ohtlikud. Hoidke lapsed töötavast seadmest eemal ja ärge laske neil seadmega mängida.
- Ärge asetage seadme kohale asju, mida lapsed võiksid üritada kätte saada.
- Kui uks on avatud, ärge toetage sellele raskeid asju ja ärge lubage lastel selle peal istuda. Muidu võib uks alla vajuda või hinged kahjustada saada.

Toote kõrvaldamine kasutuselt

WEEE direktiivi täitmine ja romuseadme kõrvaldamine:



Seade vastab Euroopa Liidu WEEE direktiivile (2012/19/EL). Seadmel on elektri- ja elektroonikaseadmete jäätmete (WEEE) liigiti kogumise tähis.

Seade on valmistatud kvaliteetsetest osadest ja materjalidest, mis sobivad ringlussevõtmiseks ja taaskasutamiseks. Ärge visake tarbetuks muutunud seadet tavalise olmeprügi ega muude jäätmete hulka.

Viige see elektri- ja elektroonikajäätmete kogumispunkti. Kogumispunktide kohta saate täpsemat teavet kohalikust omavalitsusest.

RoHS-direktiivi täitmine:

Seade vastab Euroopa Liidu RoHS-direktiivile (2011/65/EL). See ei sisalda direktiivis mainitud kahjulikke ja keelatud materjale.

Pakkematerjali kõrvaldamine

- Pakkematerjalid on lastele ohtlikud. Hoidke pakkematerjale ohutus kohas, kust lapsed neid kätte ei saa. Toote pakend on valmistatud taaskasutatavatest materjalidest. Kõrvaldage pakkematerjalid nõuetekohaselt ja sorteerige vastavalt taaskasutatavate jäätmete kogumise eeskirjadele. Ärge visake neid olmeprügi hulka.

2 Üldine teave

Ülevaade

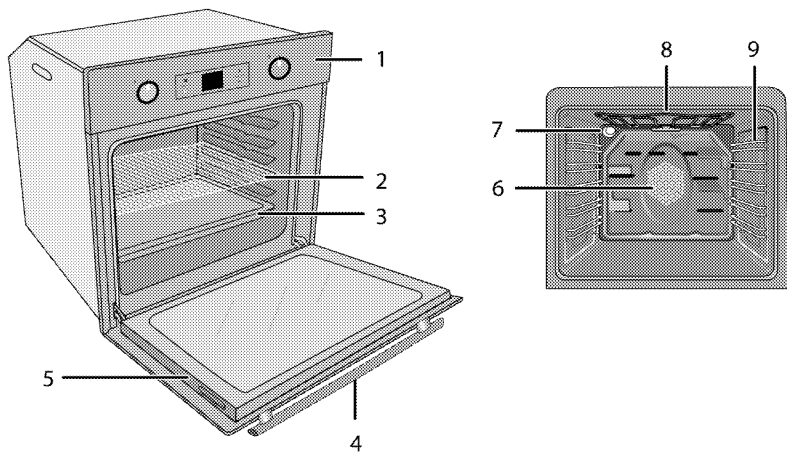

- | | | | |
|---|------------|---|--|
| 1 | Juhtpaneel | 6 | Ventilaatori mootor (terasplaadi taga) |
| 2 | Traatrest | 7 | Tuli |
| 3 | Kandik | 8 | Ülemine kuumutuselement |
| 4 | Käepide | 9 | Riivli asendid |
| 5 | Uks | | |

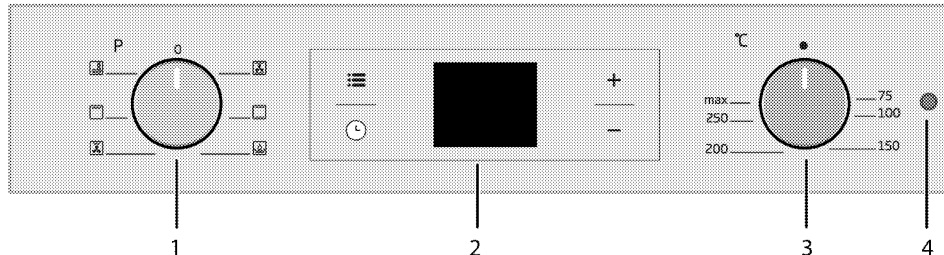

- | | |
|---|-------------------|
| 1 | Funktsiooninupp |
| 2 | Digitaalne taimer |
| 3 | Termostaatinupp |
| 4 | Termostaadilamp |

Pakendi sisu



Lisavarustus võib sõltuvalt toote mudelist varieeruda. Kõiki kasutusjuhendis kirjeldatud lisasid ei pruugi teie tootel olla.

1. **Kasutusjuhend**

2. **Harilik plaat**

Kasutatakse küpsetiste, külmutatud toitude ning suurte praadide valmistamiseks.

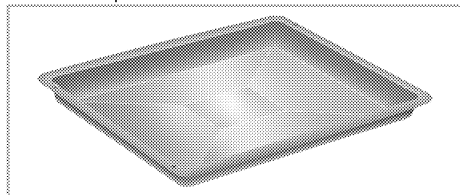

3. **Sügav ahjuplaat**

Kasutatakse küpsetiste, suurte praadide, suure veesisaldusega roogade valmistamiseks ja grillimisrasva kogumiseks.

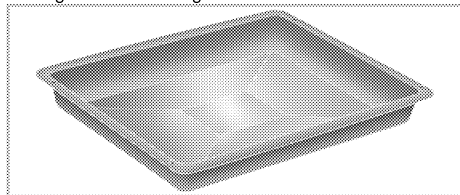

4. **Traatrest**

Kasutatakse praadide valmistamiseks või haudenõus valmistatavate roogade asetamiseks soovitud kõrgusega siinile.

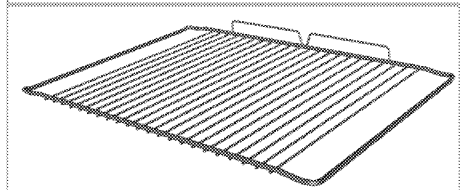
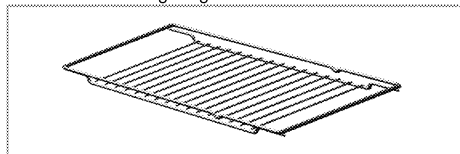

5. **Traatresti ja küpsetusplaadi asetamine teleskoopsiinidele**
(See funktsioon on valikuline. Teie tootel ei pruugi seda olla.)

Teleskoopsiinid võimaldavad küpsetusplaate ja traatresti hõlpsasti ahju panna ja ahjust välja võtta.

Kui kasutate küpsetusplaati ja traatresti teleskoopsiinidega, peavad tihvtid teleskoopsiinide tagaosas toetuma traatresti ja küpsetusplaadi servade vastu.

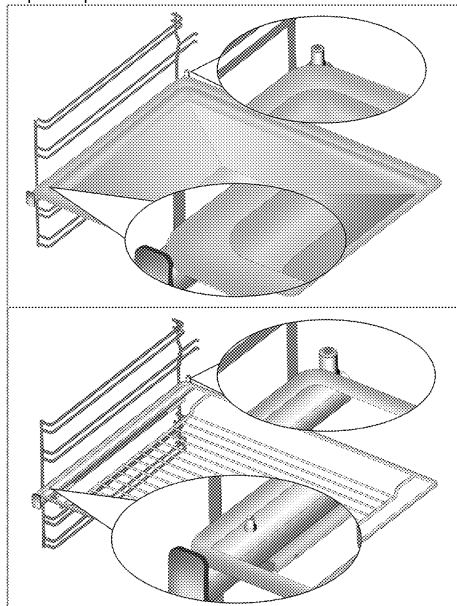

Tehnilised andmed

Pinge/sagedus	220-240 V ~ 50 Hz
Energiatarve kokku	2.4 kW
Juhtme tüüp/ristlõige	minH05VV-FG 3 x 1,5 mm ²
Välismõõtmed (kõrgus/laius/sügavus)	595 mm/594 mm/567 mm
Paigaldusmõõtmed (kõrgus/laius/sügavus)	**590 või 600 mm/560 mm/min 550 mm
Peamine ahi	Multifunktsionaalne ahi
Sisevalgusti	15/25 W
Grilli energiatarve	2.2 kW

Põhialused: teave elektriahjude energiamärgise kohta on esitatud vastavalt standardile EN 60350-1 / IEC 60350-1. Need väärtused on saadud standardkoormusel alumise-ülemise kuumutiga või ventilaatoriga kuumutusrežiimis (kui see on olemas).
Energiatõhususe klass määratakse vastavalt järgmistele prioriteetidele olenevalt sellest, kas vastav funktsioon on tootel olemas või mitte. 1 – Ökonoomne ventilaatoriga kuumutamine, 2 – Üliaeglane kuumutamine, 3 – Kiire kuumutamine, 4 – Ventilaatoriga kuumutamine (ülemine ja alumine küttekeha), 5 – Ülemise ja alumise küttekehaga kuumutamine.

** Vt Paigaldamine, lk 12.



Toote kvaliteedi parandamiseks võidakse tehnilisi andmeid etteteatamiseta muuta.



Kasutusjuhendis toodud joonised on skemaatilised ning ei pruugi teie tootega täpselt kokku langeda.



Tootel olevatel etiketidel või tootega kaasas olevas dokumentatsioonis toodud väärtused on saadud laboritingimustes vastavalt asjaomastele standarditele. Olenevalt toote töö- ja keskkonnatingimustest võivad tegelikud väärtused varieeruda.

3 Paigaldamine

Toode tuleb lasta paigaldada pädeval spetsialistil vastavalt kehtivatele eeskirjadele. Muidu muutub garantii kehtetuks. Tootja ei vastuta kahjude eest, mis tulenevad volitamata isikute tehtud protseduuridest ja võivad muuta garantii kehtetuks.



Toote paigalduskoha ning elektrisüsteemi ettevalmistamine on kliendi ülesanne.



OHT:

Toote paigaldamisel tuleb järgida kõiki gaasi- ja elektrisüsteemidele kehtestatud kohalikke eeskirju.



OHT:

Enne paigaldamist vaadake üle, kas tootel ei ole defekte. Defektide esinemisel ärge laske toodet paigaldada.

Kahjustatud toode võib kujutada ohtu.

Enne paigaldamist

Seade on mõeldud integreerimiseks kaubandusvõrgus müüdavate köögikappidega. Seadme ning köögiseinte

ja -mööbli vahele tuleb jätta ohutuse tagamiseks piisav vahe. Vt joonist (väärtused millimeetrites).

- Pinnad, sünteetilised laminaadid ja kasutatavad puhastusvahendid peavad olema kuumuskindlad (vähemalt 100 °C).
- Köögikapid peavad olema horisontaalsed ja kinnitatud.
- Kui ahju all on sahtel, tuleb ahju ja sahtli vahele paigaldada riiul.
- Kandke seadet vähemalt kahe inimesega.



Ärge paigaldage toodet külmkappide ega sügavkülmikute kõrvale. Tootest eralduv soojus suurendab jahutusseadmete energiatarvet.



Ärge kasutage toote tõstmiseks või liigutamiseks ust ega uksekäepidet.



Kui tootel on traadist sangad, lükake need pärast toote nihutamist tagasi külgeistesse.

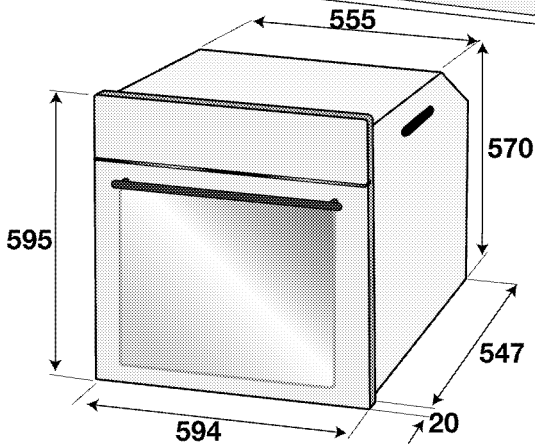
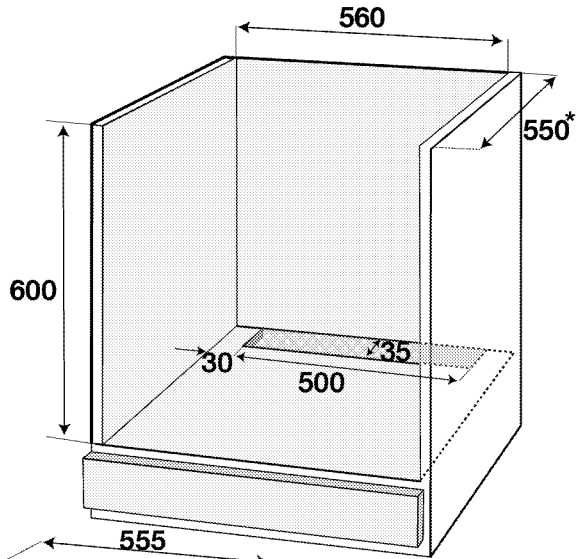
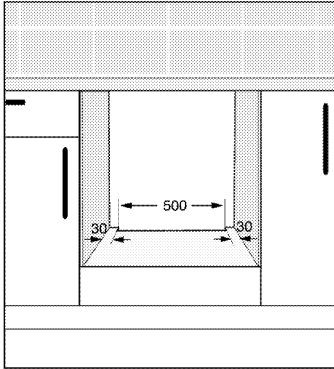
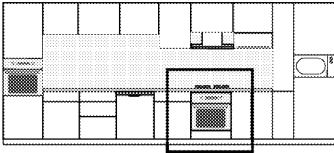

* min

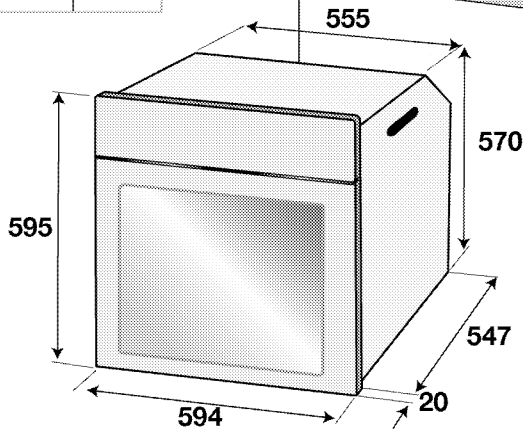
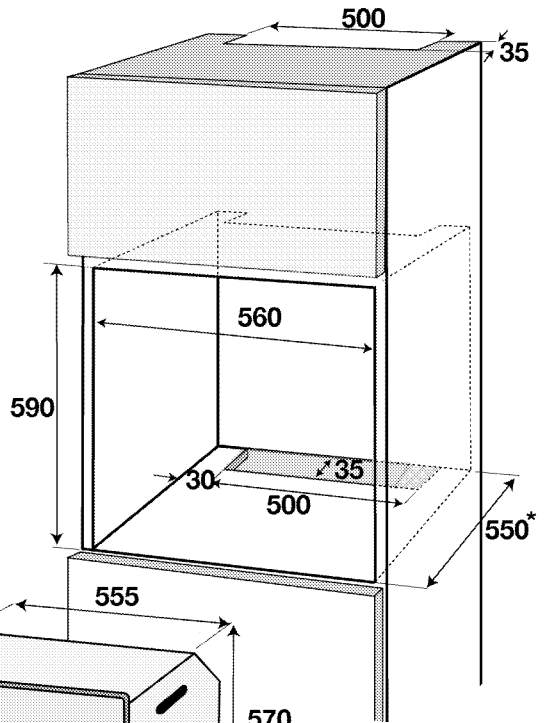
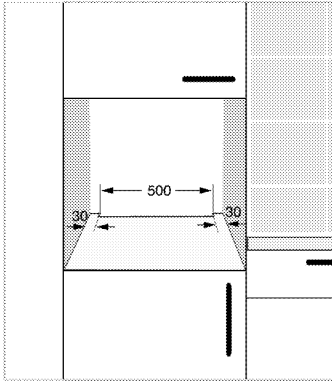
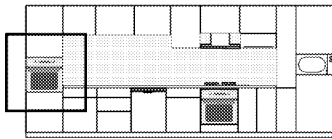

* min

Paigaldamine ja ühendamine

- Toodet tohib paigaldada ja ühendada ainult vastavalt ametlikele paigalduseeskirjadele.

Elektriühendused

Ühendage toode maandatud elektrikontakti/-liiniga, millel on sobivate näitajatega minikaitseüliliiti (vt tabelit "Tehnilised andmed"). Laske maandus paigaldada kvalifitseeritud elektrikul olenemata sellest, kas kasutate toodet transformatoriga või ilma. Meie ettevõtte ei vastuta kahjude eest, mis on tingitud toote kasutamisest ilma kohalikele eeskirjadele vastava maanduseta.



OHT:

Toote võivad vooluvõrku ühendada ainult autoriseeritud ja kvalifitseeritud isikud. Toote garantiaeg algab alles pärast nõuetekohast paigaldamist.

Tootja ei vastuta kahjude eest, mis tulenevad volitamata isikute tehtud protseduuridest.

OHT:
Toitejuhet ei tohi kinnitada klambritega, väänata ega muljuda ning see ei tohi puutuda kokku toote kuumenevate osadega. Kahjustatud toitejuhtme peab välja vahetama kvalifitseeritud elektrik. Muul juhul tuleb arvestada elektrilöögi, lühise või tulekahju ohuga!

- Ühendus peab vastama riiklikele eeskirjadele.
- Võrgutoite näitajad peavad vastama seadme tüübisildile märgitud andmetele. Tüübisildi vaatamiseks avage eesuks.
- Toote toitejuhe peab vastama tehniliste andmete tabelis toodud väärtustele.

OHT:
Enne elektritööde tegemist ühendage toode vooluvõrgust lahti.
Elektrilöögi oht!

Toitejuhtme ühendamine

i Juhtmestiku paigaldamisel tuleb järgida elektrisüsteemidele kehtestatud siseriiklikke/kohalikke eeskirju ning kasutada ahju jaoks sobivat elektrikontakti/-liini ja pistikut. Kui toote võimsus on suurem kui pistiku ja elektrikontakti/-liini (kestev) taluvusvool, tuleb toode ühendada püsielektrisüsteemi otse, kasutamata pistikut ja elektrikontakti/-liini.

1. Kui toitevoolu kõiki poolusi ei ole võimalik lahutada, tuleb ühendada vähemalt 3 mm kontaktivahega voolukatkestusseade (kaitse, liinikatkestusüliliit, kontaktor) ja kõik voolukatkestusseadme poolused peavad vastavalt IEE direktiividele paiknema toote kõrval (mitte kõrgemal). Selle juhise eiramine võib põhjustada probleeme toote kasutamisel ja muuta garantii kehtetuks.

Soovitatav on kasutada lisakaitseks jääkvoolukatkestist.

Kui tootega on kaasas juhe:

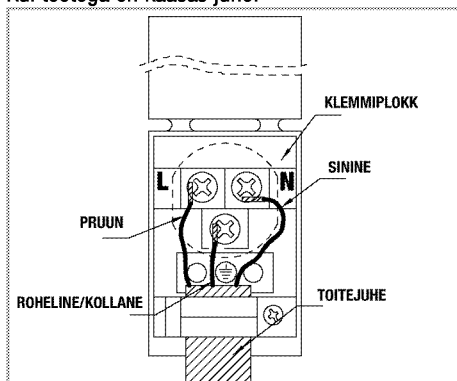

2. **Ühefaasilise ühenduse puhul** ühendage juhtmed alljärgnevalt:

- Pruun/Must juhe = L (Faas)
- Sinine/hall juhe = N (Neutraal)
- Roheline/kollane juhe = (E) (maandus)

» või

- Hall/Must juhe = L (Faas)
- Sinine/pruun juhe = N (Neutraal)
- Roheline/kollane juhe = (E) (maandus)

Toote paigaldamine

1. Lükake ahi kappi, rihtige otseks ja kinnitage paika, vältides ühtlasi toitejuhtme vigastamist ja muljumist.

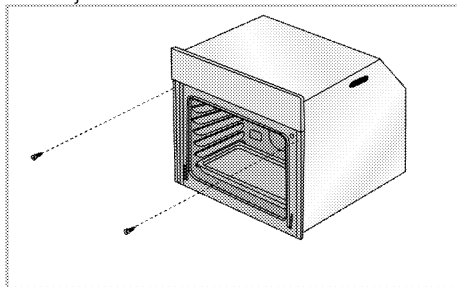

Kinnitage ahi joonisel näidatud viisil kahe kruviga. Pärast paigaldamist veenduge, et kruvid on kõvasti kinni ja ahi ei liigu. Kui ahi pole paigaldatud juhiste järgi või kruvid pole piisavalt tugevasti kinni, võib ahi kasutamise ajal ümber kukkuda.

Jahutusventilaatoriga toodete puhul (Teie tootel ei pruugi seda olla.)

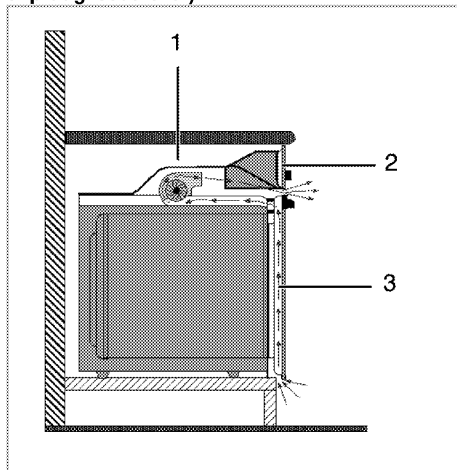

- 1 Jahutusventilaator
- 2 Juhtpaneel
- 3 Uks

Sisseehitatud jahutusventilaator jahutab nii toote esikülge kui ka kappi, kuhu toode on paigaldatud.



Jahutusventilaator töötab pärast ahju väljalülitamist veel umbes 20–30 minutit. Kui kasutasite küpsetamiseks ahju programmeeritud taimerit, lülitub küpsetusaja lõppedes koos kõigi teiste funktsioonidega välja ka jahutusventilaator.

Lõppkontroll

1. Toote kasutamine.
2. Kontrollige funktsioone.

Toote kõrvaldamine kasutuselt

- Hoidke toote originaalkarp alles ja kasutage seda toote transportimiseks. Järgige karbile märgitud juhiseid. Kui teil originaalkarpi pole, pakkige toode mullikillesse või paksu kargongi sisse ja kinnitage kindlalt teibiga.
- Et traatrest ja ahjus asuv küpsetusplaat ei saaks kahjustada ahju ust, asetage ahju ukse siseküljele papiriba, mis oleks küpsetusplaatidega ühel joonel. Teipige ahju uks külge.
- Ärge kasutage toote tõstmiseks või liigutamiseks ust ega uksekäepidet.



Ärge asetage tootele esemeid ja hoidke seda teisaldamise ajal püstiasendis.



Kontrollige toote üldilmet, et avastada võimalikke transpordi käigus tekkinud defekte.

4 Ettevalmistused

Nõuandeid energia säästmiseks

Alljärgnevad nõuanded aitavad teil oma seadet kasutada ökoloogilisel viisil ja säästa energiat:

- Kasutage ahjus tumedaid ja emailkattega küpsetusnõusid, kuna need juhivad paremini soojust.
- Roogade valmistamisel eelkuumutage ahju, kui nii on soovitatud kasutusjuhendis või retseptis.
- Küpsetamise ajal vältige ahjuukse sagedast avamist.
- Kui vähegi võimalik, küpsetage ahjus korraga mitut rooga. Traatrestile võib asetada kaks hautamisanumat.
- Samuti võib valmistada mitu rooga üksteise järel. Ahi on juba eelnevalt kuum.
- Saate säästa energiat, kui lülitate ahju välja mõned minutid enne küpsetusaja lõppu. Ärge avage ahjuust.
- Külmutatud road sulatage enne kuumutamist üles.

Esimene kasutuskord

Kellaaja sisestamine



Muudatuste tegemise ajal vilguvad ekraanil vastavad tähised.

Pärast ahju esmakordset sisselülitamist vajutage kellaaja sisestamiseks klahvi **+/-**.



Puutejuhtimisega mudelite puhul puudutage esmalt klahvi **≡** ja seejärel kasutage kellaaja määramiseks klahvi **+ / -**.

Väärtuse kinnitamiseks puudutage tähist ja oodake kinnitamiseks 4 sekundit ilma ühtki klahvi puudutamata.

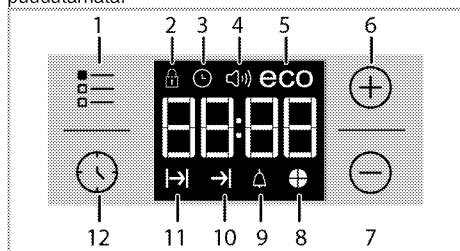

- 1 Seadistusklahv
- 2 Klahviluku sümbol
- 3 Kella tähis

- 4 Alarmi helitugevuse tähis (Teie tootel ei pruugi seda olla.)
- 5 Säästurežiimi tähis
- 6 Plussklahv
- 7 Miinusklahv
- 8 Ajasektori tähis
- 9 Märguande tähis
- 10 Küpsetusaja lõpu tähis
- 11 Küpsetusaja tähis
- 12 Programmiklahv



Kui algusaega pole määratud, hakkab kell tööle **12:00** ning kuvatakse tähis . Kui kell on õigeks pandud, tähis kaob.



Voolukatkestuse korral kellaaja sätted kustuvad. Need tuleb uuesti paika seada.

Seadme esimene puhastamine



Mõned puhastusained või -vahendid võivad pinda kahjustada. Ärge kasutage tugevatoimelisi puhastusaineid, puhastuspulbrit või -pastat ega teravaid esemeid.

1. Eemaldage kõik pakkematerjalid.
2. Pühkige seadme pindu niiske lapi või käsna ja kuivatage lapiga.

Esimene kuumutamine

Kuumutage toodet umbes 30 minutit ning seejärel lülitage see välja. Selle käigus põlevad ära võimalikud tootmisjäägid või määrdekihid.



HOIATUS

Kuumad pinnad tekitavad põletusi!
Toode võib kasutamisel olla kuum. Ärge kunagi puudutage kuumi põleteid, ahju sisekülgilgi, kütteelemente jne. Hoidke lapsed eemal!
Toote kuumu ahju pannes või välja võttes kasutage alati kuumuskindlaid pajakindaid.

Elektriahju

1. Võtke kõik küpsetusplaadid ja traatrest ahjust välja.
2. Sulgege ahjuukse.
3. Valige staatiline asend.
4. Valige kõige võimsam grilli kuumutusaste, vt *Elektriahju kasutamine, lk 19*.
5. Laske ahjul töötada umbes 30 minutit.
6. Lülitage ahi välja, vt *Elektriahju kasutamine, lk 19*.

Grillahi

1. Võtke kõik küpsetusplaadid ja traatrest ahjust välja.
2. Sulgege ahjuuks.
3. Valige kõige võimsam grilli kuumutusaste, vt *Kuidas grilli kasutada, lk 24.*
4. Laske ahjul töötada umbes 15 minutit.
5. Lülitage grill välja, vt *Kuidas grilli kasutada, lk 24.*



Seadme esimesel kasutuskorral võib paari tunni vältel esineda suitsu ja ebameeldivat lõhna. See on normaalne. Suitsu ja lõhna eemaldamiseks tuulutage ruumi. Vältige tekkiva suitsu ja lõhna sissehingamist.

5 Kuidas ahju kasutada

Üldine teave küpsetamise, röstimise ja grillimise kohta



HOIATUS

Kuumad pinnad tekitavad põletusi!
Toode võib kasutamisel olla kuum. Ärge kunagi puudutage kuumi põleteid, ahju sisekülg, kütteelemente jne. Hoidke lapsed eemal!
Toite kuuma ahju pannes või välja võttes kasutage alati kuumuskindlaid pajakindaid.



OHT:

Ahjuukse avamisel olge ettevaatlik, sest ahjust võib välja paiskuda auru.
Väljuv aur võib kõrvetada käsi, nägu ja/või silmi.

Nõuanded küpsetamiseks

- Kasutage külgevõtmatu kattega sobivaid metall- või alumiiniumnõusid või kuumuskindlaid silikoonvorme.
- Kasutage raami pinda nutikalt.
- Asetage küpsetusvorm resti keskele.
- Enne ahju või grilli sisselülitamist valige õige riilivahe. Ärge vahetage riilivahet, kui ahi on kuum.
- Hoidke ahjuuks suletuna.

Nõuanded röstimiseks

- Terve kana, kalkun ja suured lihatükid küpsevad paremini läbi, kui neid immutada kastmega, nt sidrunimahla ja musta pipraga.
- Kontidega liha küpsetamiseks kulub samas määras kontideta lihaga võrreldes umbes 15–30 minutit kauem aega.
- Liha iga sentimeetri kohta (paksus) tuleb küpsemisaega arvestada umbes 4–5 minutit.
- Laske lihal pärast küpsetusaja lõppu umbes 10 minutit ahjus jahtuda. Mahl jaguneb paremini üle kogu liha ja ei jookse liha lõikamisel välja.
- Kala tuleb asetada kuumuskindla alusega keskmisele või alumisele siinile.

Nõuanded grillimiseks

Liha, kala ja linnuliha muutuvad grillimisel kiirelt pruuniks, saavad kena kooriku ja ei muutu kuivaks. Eriti hästi sobivad grillimiseks lapikud tükid, lihavarjad ja vorstid, aga ka suure veesisaldusega köögiviljad (nt tomatid ja sibulad).

- Jaotage grillitavad tükid traatrestile või küpsetusplaadile nii, et nad ei jääks kuumuti välispiiridest välja.

- Lükake traatriil või restiga küpsetusplaat ahjus soovitud siinile. Kui kasutate grillimisel traatriilit, lükake alumisele siinile küpsetusplaat, et rasv maha ei tilguks. Ahju tuleb lükata küpsetusplaat, mis katab kogu grillimisala. Plaati ei pruugi tootega kaasas olla. Lisage küpsetusplaadile veidi vett, et seda oleks kergem puhastada.



Grillimiseks sobimatud toiduained võivad põhjustada tulekahju. Grillige ainult suurel kuumusel grillimiseks sobilikku toitu.
Ärge paigutage grillitavat toitu liiga kaugele ahju tahaossa. See on kõige kuumem piirkond ning rasvane toit võib süttida.

Elektriahju kasutamine

Valige temperatuur ja töörežiim

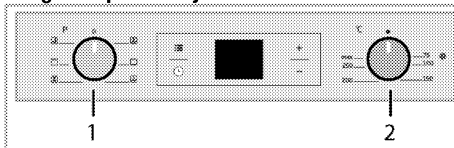

- 1 Funktsiooninupp
- 2 Termostaatnupp

1. Seadke funktsiooninupp soovitud töörežiimile.
2. Seadke temperatuurinupp soovitud temperatuurile.
» Ahi kuumeneb eelseatud temperatuurini ja jääb sellele püsima. Kuumenemise ajal on temperatuurituli sees.

Elektriahju väljalülitamine

Keerake funktsiooninupp ja temperatuurinupp väljalülitatud (ülemisse) asendisse.

Oluline on asetada traatrest traatriulile õigesti. Traatrest tuleb asetada traatriulile vahele, nagu joonisel näidatud.

Ärge lükake traatrest vastu ahju tagaseina. Et grill töötaks tõhusalt, lükake traatrest riuli esiserva juurde ja fikseerige see ukse abil.
(Varieerub olenevalt toote mudelist.)

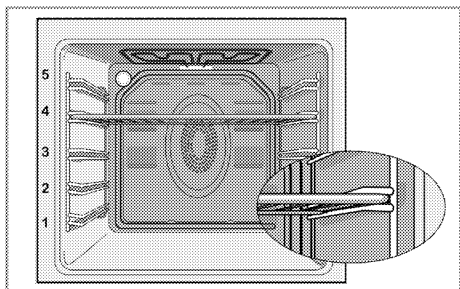

Töörežiimid

Siin näidatud töörežiimide järjekord võib erineda teie toote süsteemist.

Ülemine ja alumine kuumutus



Töötavad nii ülemine kui ka alumine küttekeha. Toitu kuumutatakse korraga nii pealt kui ka alt. Sobib näiteks kookide ja taigatoodete või vormikookide ja -roogade valmistamiseks. Kasutage küpsetamiseks korraga ainult ühte panni.

Alumine kuumutus



Töötab ainult alumine küttekeha. Sobib pitsa valmistamiseks ja toidu pruunistamiseks altpoolt.

Seda funktsiooni tuleb kasutada ka hõlpsaks auruga puhastamiseks.



Alumine/ülemine kuumutus koos ventilaatoriga



Töötavad ülemine kuumutus, alumine kuumutus ja ventilaator (tagaseinas). Kuumutatud õhk kandub ventilaatori toimel kiiresti üle terve ahju. Kasutage küpsetamiseks korraga ainult ühte panni.

Täisgrill



Töötab suur grill ahju laes. See sobib suure hulga liha grillimiseks.

- Pange suured või keskmise suurusega portsjonid grillimiseks grilli all õigesse riulivahesse.
- Pärast poolt grillimisaega pöörake toitu.

Grill + ventilaator



Grilliefekt on nõrgem kui täisgrilli kasutamisel

- Pange väikesed või keskmise suurusega portsjonid grillimiseks õige riuli asendiga grilli alla.
- Pärast poolt grillimisaega pöörake toitu.

Võimendus



See funktsioon ei sobi toidu küpsetamiseks, vaid seda kasutatakse ahju kiireks kuumutamiseks.

- Valige pärast selle funktsiooni valimist soovitud temperatuur. Temperatuuri märgutuli süttib ja ahi hakkab kuumenema.
- Tuli kustub, kui ahi on kuumaks läinud. Nüüd valige toidu küpsetamiseks soovitud funktsioon.

Ahju kella kasutamine

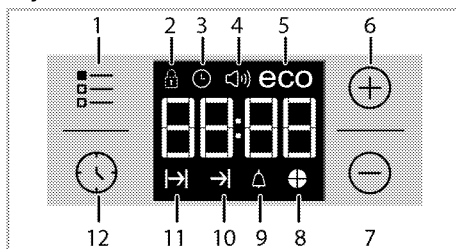





- 1 Seadistusklahv
- 2 Klahviluku sümbol
- 3 Kella tähis
- 4 Alarmi helitugevuse tähis (Teie tootel ei pruugi seda olla.)
- 5 Säästurežiimi tähis
- 6 Plussklahv
- 7 Miinusklahv
- 8 Ajasektori tähis
- 9 Märkuande tähis
- 10 Küpsetusaja lõpu tähis
- 11 Küpsetusaja tähis
- 12 Programmiklahv

	Maksimaalne küpsetamise lõpetamiseks seata aeg on 5 tundi ja 59 minutit. Voolukatkestuse korral programm tühistatakse. Ahi tuleb uuesti programmeerida.
	Seadistamise ajal vilguvad ekraanil vastavad tähised. Sätete rakendumiseks peate mõne hetke ootama.
	Kui küpsetamissätteid pole valitud, ei saa kellaega määrata.
	Kui on määratud küpsetusaeg, siis näidatakse küpsetamise ajal järelejäänud aega.

Küpsetamine määratud küpsetusajaga









Ahju saab seadistada nii, et see lõpetab etteantud aja möödumisel tööd. Selleks määratakse taimeri abil küpsetusaeg.



1. Valige küpsetusfunktsioon.
 2. Puudutage klahvi , kuni ekraanile ilmub küpsetusaja tähis .
 3. Määrake küpsetusaeg klahviga / .
- » » Kui küpsetusaeg on määratud, jääb tähis  koos aja sümboliga ekraanile.
4. Pange toit ahju ja seadke temperatuurinupu abil temperatuur. Küpsetamise algab.

» Küpsetamise alguses, kui kõik aja tähise osad on süttinud, algab küpsetusaja pöördarvestus. Määratud küpsetusaeg on jagatud neljaks võrdseks osaks. Iga osa aja täitumisel lülitub selle osa tähis välja. Tänu sellele on teil hea ülevaade kui palju aega on jäänud küpsetamise lõpuni võrreldes kogu küpsetusajaga.

Küpsetusaja lõpu hilisemaks seadmine

Pärast küpsetusaja määramist taimeri abil saate seada küpsetusaja lõpu hilisemaks.

1. Valige küpsetusfunktsioon.
 2. Puudutage klahvi , kuni ekraanile ilmub küpsetusaja tähis .
 3. Määrake küpsetusaeg klahviga / .
- » » Kui küpsetusaeg on määratud, jääb küpsetamise tähis  põlema.
4. Puudutage klahvi , kuni ekraanile ilmub küpsetusaja lõpu tähis .
 5. Küpsetusaja lõpu määramiseks vajutage klahvi / .

» Kui küpsetusaeg on määratud, jäävad tähised  ja  koos aja sümboliga ekraanile. Pärast küpsetamise algust tähis  kaob.

6. Pange toit ahju ja seadke temperatuurinupu abil temperatuur. Küpsetamise algab.

» Ahju taimer arvutab välja küpsetamise algusaja, lahutades küpsetamise kestuse küpsetusaja lõpust.

Küpsetamise algusaja saabudes aktiveeritakse valitud töörežiim ning ahi soojeneb määratud temperatuurini. Määratud temperatuur püsib küpsetusaja lõpuni.



» Küpsetamise alguses, kui kõik aja tähise osad on süttinud, algab küpsetusaja pöördarvestus. Määratud küpsetusaeg on jagatud neljaks võrdseks osaks. Iga osa aja täitumisel lülitub selle osa tähis välja. Tänu sellele on teil hea ülevaade kui palju aega on jäänud küpsetamise lõpuni võrreldes kogu küpsetusajaga.

7. Kui küpsetamine on lõppenud, ilmub ekraanile teade "End" (Lõpp) ning kõlab taimeri märguandesignaali.
8. Märguandesignaali kestab 2 minutit. Märguandesignaali vaigistamiseks vajutage suvalist klahvi. Märguandesignaali vaigistatakse ning ekraanile ilmub jooksev kellaeg.

 Kui vajutate märguandesignaali lõppedes suvalist klahvi, alustab ahi uuesti tööd. Keerake temperatuurinupp ja funktsiooninupp asendisse "0" (Väljalülitatud), et ahi lülituks välja ega hakkaks pärast märguanda lõppu uuesti tööle.



Klahviluku sisselülitamine

Ahju kasutamist saab tõkestada, aktiveerides klahviluku funktsiooni.

1. Puudutage klahvi , kuni ekraanile ilmub tähis .
- » Ekraanile ilmub tähis "OFF" (Väljalülitatud).
2. Klahviluku sisselülitamiseks vajutage klahvi .
- » Kui klahvilukk on aktiveeritud, ilmub ekraanile tähis "On" (Sisselülitatud) ja tähis  jääb põlema.

 Kuni klahviluku funktsioon on sisse lülitatud, ei saa ahju klahve kasutada. Voolukatkestuse korral klahvilukku ei tühistata.

Klahviluku väljalülitamiseks puudutage

1. Puudutage klahvi , kuni ekraanile ilmub tähis .
- » Ekraanile ilmub tähis "On" (Sisselülitatud).
2. Klahviluku väljalülitamiseks vajutage klahvi .
- » Kui klahvilukk on välja lülitatud, ilmub ekraanile tähis "OFF" (Väljalülitatud).

Märguandekella seadmine

Seadme kella saab kasutada märguande või meeldetuletuse funktsioonis küpsetusprogrammist sõltumatult.

Märguandekella funktsioon ei mõjuta ahju tööd. Seda kasutatakse ainult hoiatusena. Näiteks võib seda kasutada, kui soovite küpsetit teatud aja möödudes ümber pöörata. Määratud aja möödumisel edastab taimer hoiatussignaali.

1. Puudutage klahvi , kuni ekraanile ilmub tähis .





Maksimaalne märguande aeg on 23 tundi ja 59 minutit.

2. Määrake märguande kestus klahviga .



Märguandesignaali, kellaaja ja ekraani heleduse funktsiooniklahvid ning temperatuuri klahvid peavad olema väljalülitatud asendis 0 (OFF).

» Pärast märguande aja sisestamist jääb tähis  põlema ja ekraanile ilmub märguande aeg.



3. Kui märguande aeg on möödas, hakkab tähis  vilkuma ning kõlab märguandesignaali.

Märguandesignaali väljalülitamine

1. Märguandesignaali kestab 2 minutit. Märguandesignaali vaigistamiseks vajutage suvalist klahvi.

» Märguandesignaali vaigistatakse ning ekraanile ilmub jooksev kellaeg.



Märguande tühistamine

1. Märguande tühistamiseks puudutage klahvi , kuni ekraanile ilmub tähis .
2. Vajutage pikalt klahvi , kuni ekraanile ilmub "00:00".



Ekraanile ilmub märguande aeg. Kui korraga on seatud märguande aeg ning küpsetusaeg, näidatakse ekraanil lühemat ajavahemikku.

Märguandesignaali muutmise

1. Puudutage klahvi , kuni ekraanile ilmub tähis ,
2. Seadistage klahviga  soovitud märguandesignaali.
3. Määratud signaal aktiveeritakse veidi aja pärast.
- » Valitud märguandesignaali näidatakse ekraanil kujul "b-01", "b-02" või "b-03".

Kellaaja muutmise

Varem sisestatud kellaaja muutmise

1. Puudutage klahvi , kuni ekraanile ilmub tähis .
2. Määrake kellaage klahviga .



3. Määratud aeg aktiveeritakse veidi aja pärast.

Säästurežiim



Säästurežiimi abil saate energiat kokku hoida, määrates ahju küpsetusaja.

Sellel režiimil lülitatakse küttekehad enne küpsetusaja lõppu välja ning kasutatakse ahju jääksoojust.

Säästurežiimi määramine



1. Puudutage tähist , kuni ekraanile ilmub säästurežiimi tähis **eco**.
- » Ekraanile ilmub tähis "OFF" (Väljalülitatud).
2. Säästurežiimi sisselülitamiseks puudutage klahvi .
- » Kui klahviluk on aktiveeritud, ilmub ekraanile tähis "On" (Sisselülitatud) ja säästurežiimi tähis jääb põlema.

Säästurežiimi väljalülitamine

1. Puudutage tähist , kuni ekraanile ilmub säästurežiimi tähis **eco**.
- » Ekraanile ilmub tähis "On" (Sisselülitatud).
2. Säästurežiimi väljalülitamiseks puudutage klahvi .
- » Kui klahviluk on välja lülitatud, ilmub ekraanile tähis "Off" (Väljalülitatud).

Ekraani heleduse määramine

(See funktsioon on valikuline. Teie tootel ei pruugi seda olla.)

1. Puudutage klahvi , kuni ekraanile ilmub selle heledust näitav **d-01**, **d-02** või **d-03**.
2. Määrake soovitud heledus klahviga .
- » Määratud aeg aktiveeritakse veidi aja pärast.

Küpsetusaegade tabel













Tabelis esitatud ajad on mõeldud orientiiriks. Tegelik aeg võib varieeruda olenevalt toidu temperatuurist, paksusest, tüübist ja teie enda toiduvalmistuseelustest.

Küpsetamine ja röstimine



1. siiniks loetakse ahju **alumist** riiulivahet.





Roog	Plaatide arv	Kasutatavad lisatarvikud	Töörežiim	Siini asend	Temperatuur (°C)	Küpsetusaeg (ligikaudne, min)
Koogid küpsetusplaadil	Üks plaat	Hariilik plaat*		3	180	25 ... 30
Koogid vormis	Üks plaat	Koogivorm ja traatrest**		2	180	40 ... 50
Väikesed koogid	Üks plaat	Hariilik plaat*		3	160	25 ... 35
Biskviitkook	Üks plaat	26 cm läbimõõduga ümmargune tordivorm traatrestil**		3	160	25 ... 35
Küpsised	Üks plaat	Küpsetusplaat*		3	180	25 ... 30

Taignatooted	Üks plaat	Hariilik plaat*		2	200	30 ... 40
Muretaigen	Üks plaat	Hariilik plaat*		2	200	25 ... 35
Juuretis	Üks plaat	Hariilik plaat*		2	200	35 ... 45
Lasanje	Üks plaat	Klaasis/metallist kandiline vorm traatrestli**		2 - 3	200	30 ... 40
Pitsa	Üks plaat	Hariilik plaat*		2	200 ... 220	15 ... 20
Biifsteek (suur tükk) / praad	Üks plaat	Hariilik plaat*		3	25 min 250/max, seejärel 180 ... 190	100 ... 120
Lambakints (pajaroog)	Üks plaat	Hariilik plaat*		3	25 min 220 seejärel 180 ... 190	70 ... 90
Kanapraad (1,8-2 kg)	Üks plaat	Hariilik plaat*		2	15 min 250/max, seejärel 180 ... 190	60 ... 80
Kalkun (5.5 kg)	Üks plaat	Hariilik plaat*		1	25 min 250/max, seejärel 180 ... 190	150 ... 210
Kala	Üks plaat	Hariilik plaat*		3	200	20 ... 30

Kõigi toitude puhul on soovitatav eelkuumutamine.
* Lisatarvikud ei pruugi kuuluda komplekti.
** Lisatarvikud ei kuulu komplekti. Lisatarvikud on kaubanduses saadaval.

Küpsetustabel testitoitudele

Selle küpsetustabeli toidud on valmistatud järgides standardit EN 60350-1, et riiklikel kontrollasutustel oleks tooteid lihtsam testida

Roog	Plaatide arv	Kasutatavad lisatarvikud	Töörežiim	Siini asend	Temperatuur (°C)	Küpsetusaeg (ligikaudne, min)
Murekook	Üks plaat	Hariilik plaat*		3	140	20 ... 30
Väikesed koogid	Üks plaat	Hariilik plaat*		3	160	25 ... 35
Biskviitkook	Üks plaat	26 cm läbimõelduga ümmargune tordivorm traatrestli**		3	160	25 ... 35
Õunapirukas	Üks plaat	20 cm läbimõelduga ümmargune must metallist nõu traatrestli**		2	180	50 ... 60

Kõigi toitude puhul on soovitatav eelkuumutamine.
* Lisatarvikud ei pruugi kuuluda komplekti.
** Lisatarvikud ei kuulu komplekti. Lisatarvikud on kaubanduses saadaval.

Nõuandeid kookide küpsetamiseks

- Kui kook on liiga kuiv, suurendage temperatuuri umbes 10 °C võrra ja lühendage küpsetusaega.
- Kui kook on liiga niiske, kasutage vähem vedelikku või vähendage temperatuuri 10 °C võrra.
- Kui kook on pealt liiga pruun, asetage see madalamale siinile, vähendage temperatuuri ja pikendage küpsetusaega.
- Kui kook on seest hästi läbi küpsenud, kuid pealt toores, kasutage vähem vedelikku, vähendage temperatuuri ja pikendage küpsetusaega.

Nõuandeid küpsetiste tegemiseks

- Kui küpsetis on liiga kuiv, suurendage temperatuuri umbes 10 °C võrra ja lühendage küpsetusaega. Niisutage taigakihte piimast, õlist, munast ja jogurtist tehtud kastmega.
- Kui küpsemine võtab liiga kaua aega, siis vaadake, et taigen ei ulatuks üle plaadi servade.
- Kui küpsetise pealispind pruunistub, aga alumine osa ei küpse, siis veenduge, et te pole küpsetise alaosas liiga palju kastet kasutanud. Püüdke jaotada kastet taigakihtide vahele ja peale

võrdsetes kogustes, et need pruunistuks ühtlaselt.



Küpsetage vastavalt küpsetustabelis toodud režiimile ja temperatuurile. Kui alumine osa pole ikka piisavalt pruunistunud, asetage see järgmine kord madalamale siinile.

Nõuandeid köögiviljade küpsetamiseks

- Kui köögiviljade küpsetusnõus saab mahl otsa ja need hakkavad kuivama, siis tasub köögivilju küpsetada ahjuplaadi asemel kaanega pannil. Kaanega suletud nõus jääb toit mahlasemaks.
- Kui köögiviljaroog jääb tooreks, keetke köögiviljad eelnevalt läbi või valmistage neid nagu purgitoitu ja asetage siis ahju.

Kuidas grilli kasutada



HOIATUS

Sulgege grillimise ajaks ahjuuks. Kuumad pinnad võivad tekitada põletusi!

Grilli sisselülitamine

1. Keerake funktsiooninupp soovitud grillitähisele.
 2. Seejärel valige soovitud grillimistemperatuur.
 3. Vajadusel eelkuumutage ahju umbes 5 minutit.
- » Süttib temperatuuri märgutuli.

Grilli väljalülitamine

1. Keerake funktsiooninupp väljalülitatud (ülemisse) asendisse.



Grillimiseks sobimatud toiduained võivad põhjustada tulekahju. Grillige ainult suurel kuumusel grillimiseks sobilikku toitu. Ärge paigutage grillitavat toitu liiga kaugele ahju tahaossa. See on kõige kuumem piirkond ning rasvane toit võib süttida.

Küpsetamisaegade tabel grillimiseks

Grillimine elektrigrilliga

Toit	Kasutatavad lisatarvikud	Siini asend	Soovitatav temperatuur (°C)**	Grillimisaeg (ligikaudu)
Kala	Traatrest	4..5	250	20...25 min. #
Viljutatud kana	Traatrest	4..5	250	25...35 min.
Lambakarbonaad	Traatrest	4..5	250	20...25 min.
Röstliif	Traatrest	4..5	250	25...30 min. #
Vasikakarbonaad	Traatrest	4..5	250	25...30 min. #
Röstleib *	Traatrest	4	250	1...3 min.

sõltuvalt paksusest

*Eelsoojendage 5 minutit

**Kui teie toote grillimistemperatuuri ei saa reguleerida, töötab grill soovitatud temperatuuril.

Selle küpsetustabeli toidud on valmistatud järgides standardit EN 60350-1, et riiklikel kontrollasutustel oleks tooteid lihtsam testida

Toit	Kasutatavad lisatarvikud	Siini asend	Temperatuur (°C)	Küpsetusaeg (ligikaudne, min)
Röstleib	Traatrest	4	250	1...3 min
Lihapallid (oomalilha) - 12 tüki	Traatrest	4	250	25...35 min

Keerake toitu, kui möödunud on 2/3 kogu grillimisajast.

Kõiki grillitavaid toiduaineid on soovitatav 5 minutit eelkuumutada.

6 Hoidmine ja hooldus

Üldine teave

Toote kasutusiga pikeneb ja probleeme tekib harvem, kui toodet regulaarselt puhastada.

**OHT:**

Enne hooldus- ja puhastustööde alustamist ühendage toode vooluvõrgust lahti. Elektrilöögi oht!

**OHT:**

Enne toote puhastamist laske sellel maha jahtuda. Kuumad pinnad võivad tekitada põletusi!

- Puhastage toodet põhjalikult pärast iga kasutuskorda. Sel viisil on lihtsam eemaldada toiduvalmistusjäätke, vältides nende kõrbemist seadme järgmisel kasutuskorral.
- Toote puhastamiseks pole vaja spetsiaalseid puhastusvahendeid. Kasutage toote puhastamiseks sooja vett koos vedela pesuvahendiga, pehmet lappi või käsna ning kuivatamiseks kuiva lappi.
- Liigne vedelik tuleb pärast puhastamist alati ära pühkida ja pritsmed kohe kuivatada.
- Ärge kasutage roostevabast terasest või inoxid pindade ja käepideme puhastamiseks puhastusvahendeid, mis sisaldavad hapet või kloriidi. Nende osade puhastamiseks kasutage pehmet lappi ja vedelat puhastusvahendit (mitteabrasiivset), tõmmates lapiga ainult ühes suunas.



Mõned puhastusained või -vahendid võivad pinda kahjustada.

Ärge kasutage tugevtoimelisi puhastusaineid, puhastuspulbrit või -pastat ega teravaid esemeid.



Ärge kasutage puhastamiseks aurupuhasteid, muidu võite saada elektrilöögi.

Juhtpaneeli puhastamine

Puhastage juhtpaneeli ja nuppe niiske lapiga ning seejärel pühkige need kuivaks.



Ärge eemaldage juhtpaneeli puhastamiseks nuppe, kui teie tootel neid on.

Muidu võite juhtpaneeli kahjustada!

Ahju puhastamine

Külgešina puhastamine (Varieerub olenevalt toote mudelist.)

(See funktsioon on valikuline. Teie tootel ei pruugi seda olla.)

1. Eemaldage küljeraami eesmine osa, tõmmates seda külgeseinast eemale.
2. Võtke küljeraam välja, tõmmates seda enda suunas.

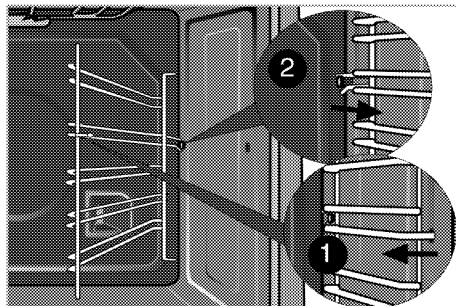

Katalüütilised seinad

(See funktsioon on valikuline. Teie tootel ei pruugi seda olla.)

Teie toote külgeseinad (A) ja/või tagasein (B) võivad seestpoolt olla kaetud katalüütilise emailiga. Katalüütilised seinad on heledat matti värvi ja poorse pinnaga. Ahju katalüütilisi seinu ei tohiks puhastada. Tänu perforeeritud struktuurile imavad katalüütilised pinnad rasva ja kui pind on rasvaga täitunud, hakkab see läikima. Sellisel juhul on soovitatav osad välja vahetada.

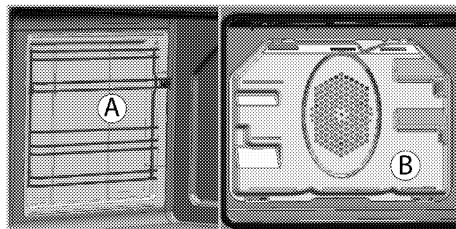

Hõlbus auruga puhastamine

Muudab puhastamise hõlpsaks, kuna mustus (mis ei ole liiga kauaks puhastamata jäänud) pehmeneb ahju sisemuses tekkiva auru ja sisepindadele kondenseeruvate veepiiskade toimele.

1. Võtke ahjust välja kõik lisad.
2. Valage ahjuplaadile 500 ml vett ja asetage plaat ahju teisele restile.

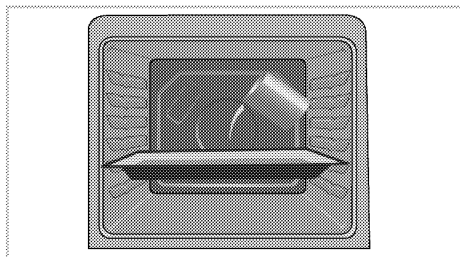

3. Seadke ahju lihtne puhastamine auru režiim ja käivitada 100 ° C juures 25 minutit.
4. Avage uks ja pühkige ahju sisepindu niiske käsna või lapiga.
5. Kasutage tõrkosa mustuse eemaldamiseks sooja vett koos vedela pesuvahendiga, pehmet lappi või käsna ning kuivatamiseks kuiva lappi.



Hõlpsa auruga puhastamise režiimi kasutamisel aurustub ahju sisemusse kogunenud jääkide/mustuse pehendamiseks plaadile paigutatud vesi ning ahju sisemusse ja ahjuukse klaasi siseküljele moodustub kondensatsioon, seepärast võib ahjuukse avamisel vett tilkuda. Pühkige kondensatsioon ära kohe, kui avate ahjuukse.

Ahjuukse puhastamine

Kasutage ahjuukse puhastamiseks sooja vett koos vedela pesuvahendiga, pehmet lappi või käsna ning kuivatamiseks kuiva lappi.



Ärge kasutage ukse puhastamiseks kareid abrasiivseid puhastusvahendeid või teravaid metallkraabitsaid. Need võivad pinda kriimustada ning klaasi lõhkuda.

Ahjuukse eemaldamine

1. Avage eesuks (1).
2. Avage eesukse paremal ja vasakul küljel asuva hingede pesa (2) klambrid, vajutades neid alla joonisel kujutatud viisil.

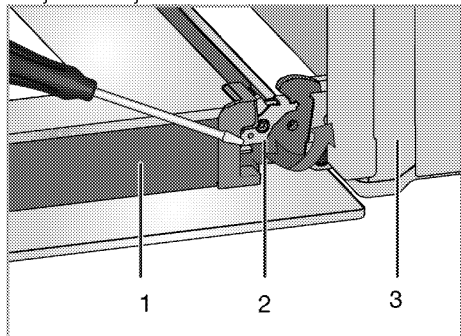

1 Uks

- 2 Hinge lukk(suletud asend)
- 3 Ahi
- 4 Hinge lukk(avatud positsioon)

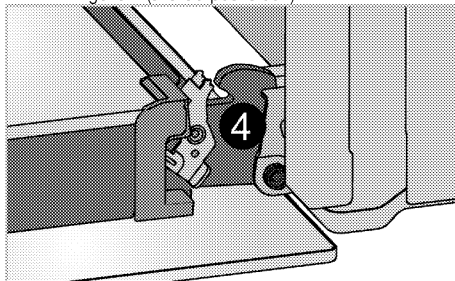

3. Liigutage eesust poolles ulatuses.

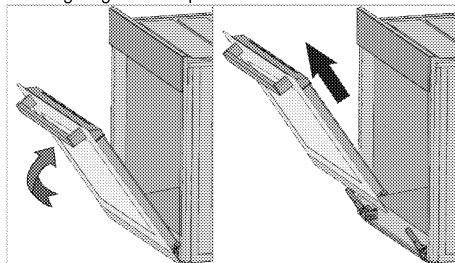

4. Eemaldage eesuks seda ülespoole tõmmates ja paremast ning vasakust hingest vabastades.



Ukse tagasipanemisel tuleb eemaldamistoiminguid korrata vastupidises järjekorras. Ärge unustage ukse taaspaidamisel sulgeda hinge pesa juures olevaid klambreid.

Ukse siseklaasi eemaldamine

(See funktsioon on valikuline. Teie tootel ei pruugi seda olla.)

Ahjuukse sisemist klaaspaneeli saab puhastamiseks eemaldada.

1. Avage ahjuuks.

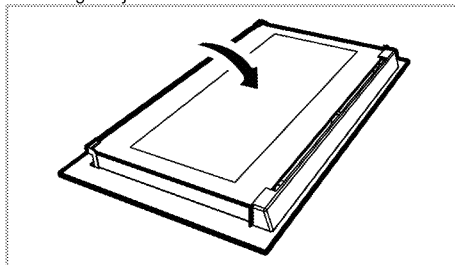

2. Eemaldage eesukse ülaossa paigaldatud plastosa, tõmmates seda enda poole.

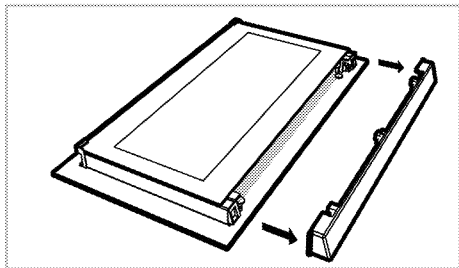

3. Kergitage kõige seespoolsemat klaaspaneeli (1) veidi tähise **A** suunas ja tõmmake see tähise **B** suunas välja, nagu joonisel näidatud.

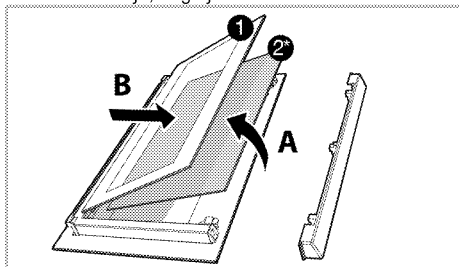

- 1 Kõige seespoolsem klaaspaneel
 2* Sisemine klaaspaneel (Teie tootel ei pruugi seda olla.)
4. Kui teie toode on varustatud sisemise klaaspaneeliga (2), eemaldage samamoodi ka teine sisemine klaaspaneel (2).
5. Ukse kokkumonteerimisel tuleb esimese asjana paigaldada sisemine klaaspaneel (2). Asetage klaaspaneeli kaldnurk nii, et see toetub plastpesa sisemise klaaspaneeliga). Sisemine klaaspaneel (2) tuleb paigaldada plastist pesasse kõige seespoolsema klaaspaneeli (1) lähedale.
6. Kõige seespoolsema klaaspaneeli (1) paigaldamisel jätke trükiga külg sisemise klaaspaneeli (1) alumine nurk peab asetuma alumisse plastpesasse.
7. Suruge plastosa vastu raami, kuni kuulete klõpsatust.

Ahjuvalgusti piri vahetamine



OHT:

Et vältida elektrilöögi ohtu, vaadake enne ahju lambi vahetamist, et toode oleks vooluvõrgust lahti ühendatud ning maha jahtunud. Kuumad pinnad võivad tekitada põletusi!



Selles ahjus kasutatakse hõõglampi võimsusega alla 40 W, kõrgusega alla 60 mm, läbimõõduga alla 30 mm või halogeenlampi pistikupesaga G9, võimsusega alla 60 W. Lambid sobivad kasutamiseks temperatuuril üle 300 ° C. Ahjulampe saab hankida volitatud hooldusagendidelt või litsentsiga tehnikutelt.



Valgusti asukoht ei pruugi olla sama mis joonisel.



Sellel seadmel kasutatud lamp pole sobiv koduse majapidamise valgustamiseks. Selle lambi eesmärk on aidata kasutajal toiduaineid paremini näha.



Sellel seadmel kasutatud lambid peavad vastu pidama ekstreemsetele tingimustele, nt üle 50 °C temperatuurile.

Kui ahjul on ümar valgusti:

1. Lahutage toode vooluvõrgust.
2. Keerake vastupäeva lahti klaaskate.

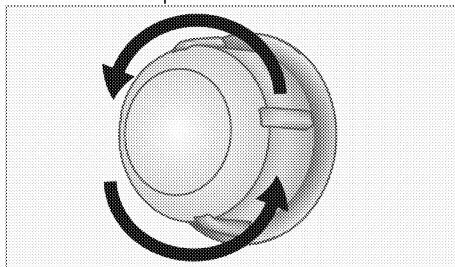

3. Kui teie ahjutuli on alloleval joonisel kujutatud (A) tüüpi, eemaldage see joonisel näidatud viisil keerates ja asendage uuega. Kui teie ahjutuli on (B) tüüpi, eemaldage see joonisel näidatud viisil tõmmates ja asendage uuega.

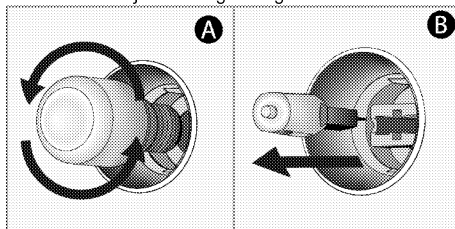

4. Paigaldage klaaskate tagasi.

7 Probleemide lahendamine

Kasutamise ajal tuleb ahjust auru.

- Auru tekkimine töötamisel on tavaline. >>> *Tegemist ei ole rikkega.*

Toote kuumenemisel ja jahtumisel on kuulda metalset heli.

- Metallosade kuumenemisel võivad need paisuda ning tekitada hääli. >>> *Tegemist ei ole rikkega.*

Toode ei tööta.

- Võrgukaitse on rakendunud või läbi põlenud. >>> *Kontrollige elektrikiirbi korke. Vajadusel vahetage või lähtestage need.*
- Toode ei ole ühendatud (maandatud) pistikupessa. >>> *Kontrollige pistiku ühendust.*

Ahju tuli ei tööta.

- Ahju pirn on vigane. >>> *Vahetage pirn välja.*
- Voolukatkestus. >>> *Kontrollige, kas vool on olemas. Kontrollige elektrikiirbi kaitsmeid. Vajadusel vahetage või lähtestage kaitsmed.*

Ahi ei lähe soojaks.

- Ei pruugi olla seatud konkreetse küpsetusfunktsiooni ja/või temperatuuri jaoks. >>> *Määrake konkreetne küpsetusfunktsioon ja/või temperatuur.*
- Taimer on seadistamata (taimeriga mudelitel). >>> *Sisestage kellaeg. (Mikrolaineahjuga toodetel juhib taimer ainult mikrolaineahju.)*
- Voolukatkestus. >>> *Kontrollige, kas vool on olemas. Kontrollige elektrikiirbi kaitsmeid. Vajadusel vahetage või lähtestage kaitsmed.*

Kellaeg vilgub või kella tähis põleb (taimeriga mudelitel).

- Vahepeal on toimunud voolukatkestus. >>> *Pange kell õigeks / lülitage toode välja ja seejärel uuesti sisse.*



Kui teil ei õnnestu probleemi käesolevas lõigus antud juhiste kohaselt lahendada, konsulteerige volitatud teenindusega või edasimüüjaga, kellelt te toote ostsite. Ärge kunagi üritage rikkis toodet ise parandada.

