

1

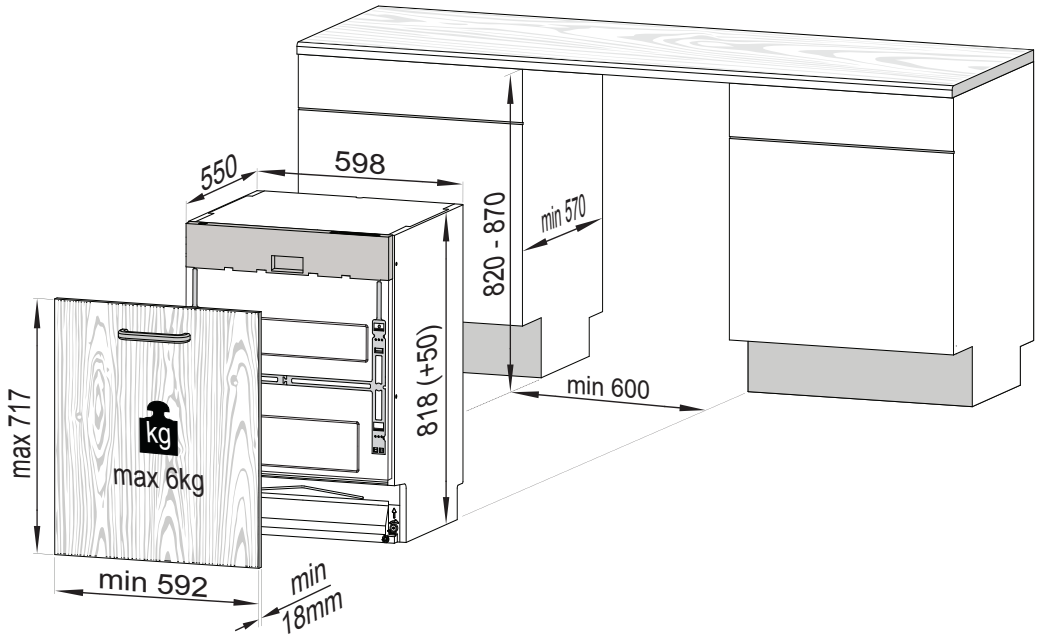

2

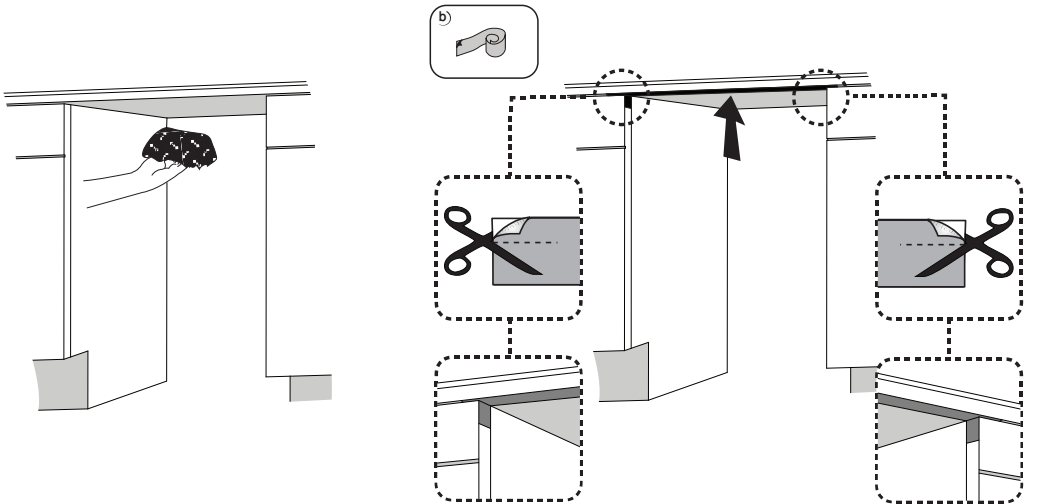

3

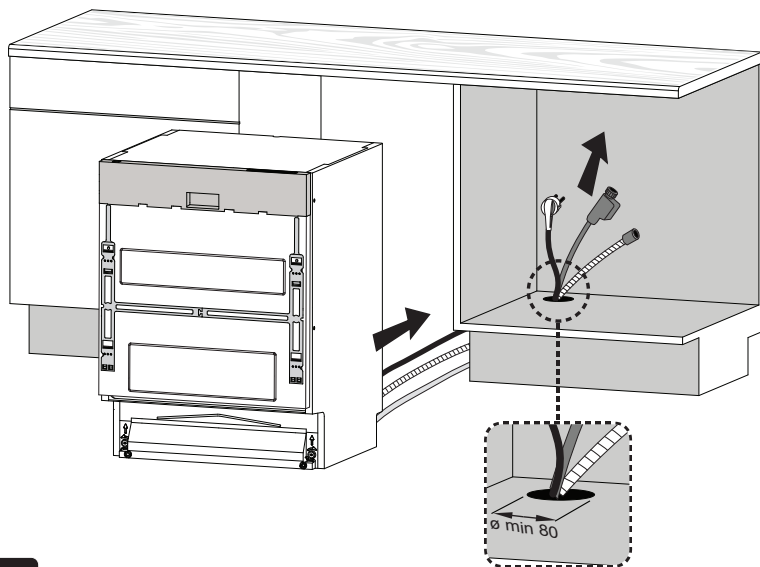

4

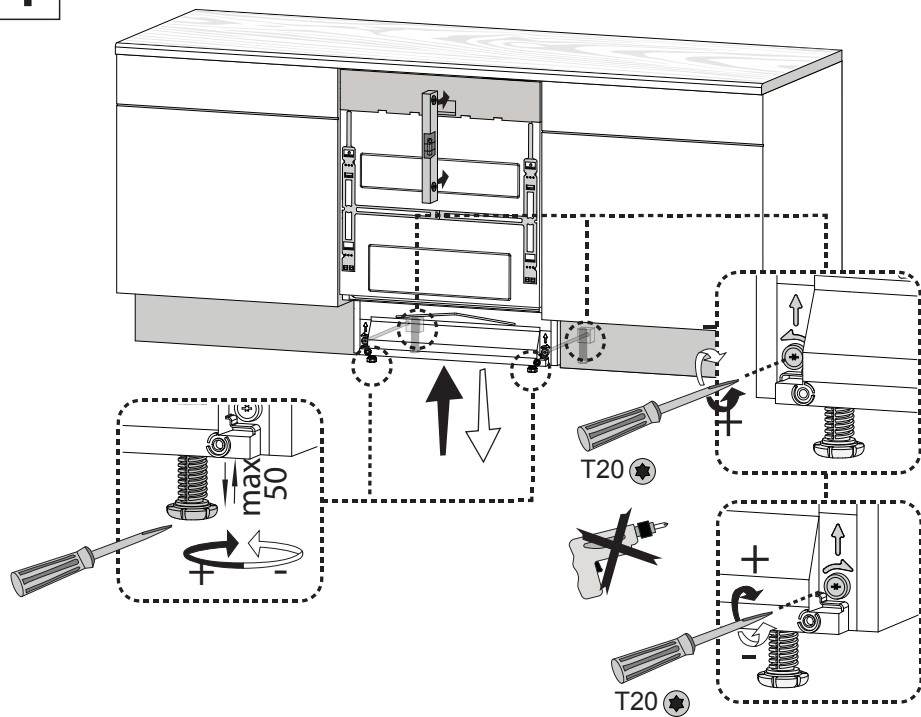

5

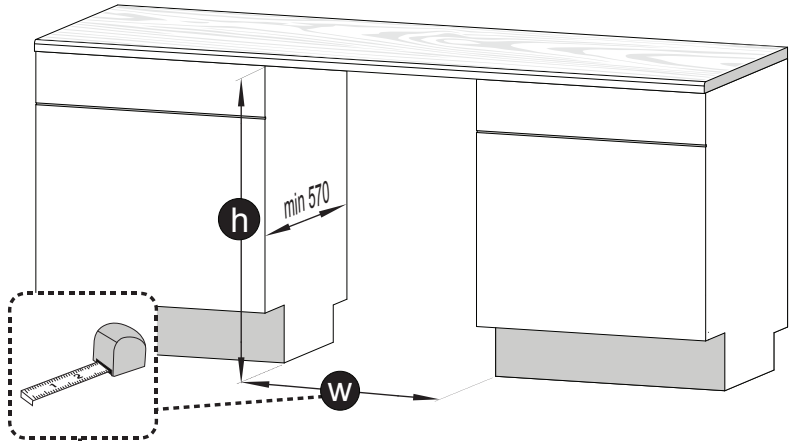

$w > 610$

6

$w = 600 - 610$

8

6

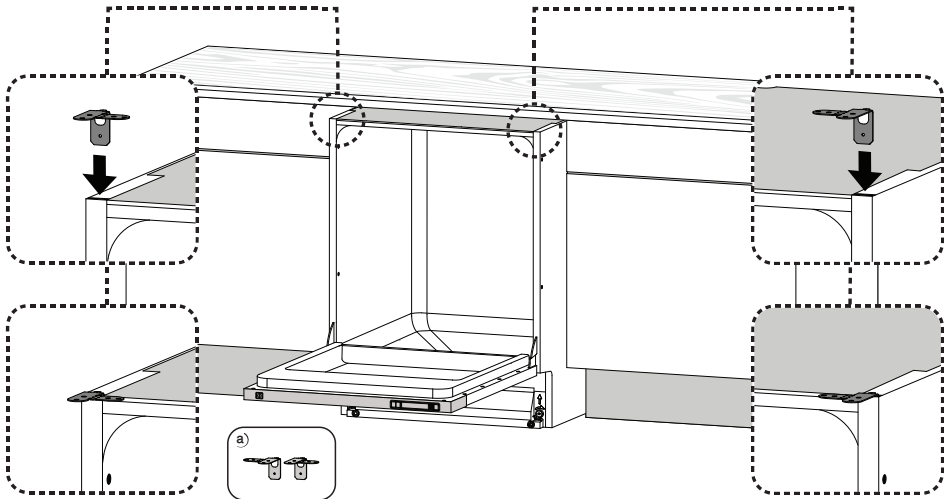

7

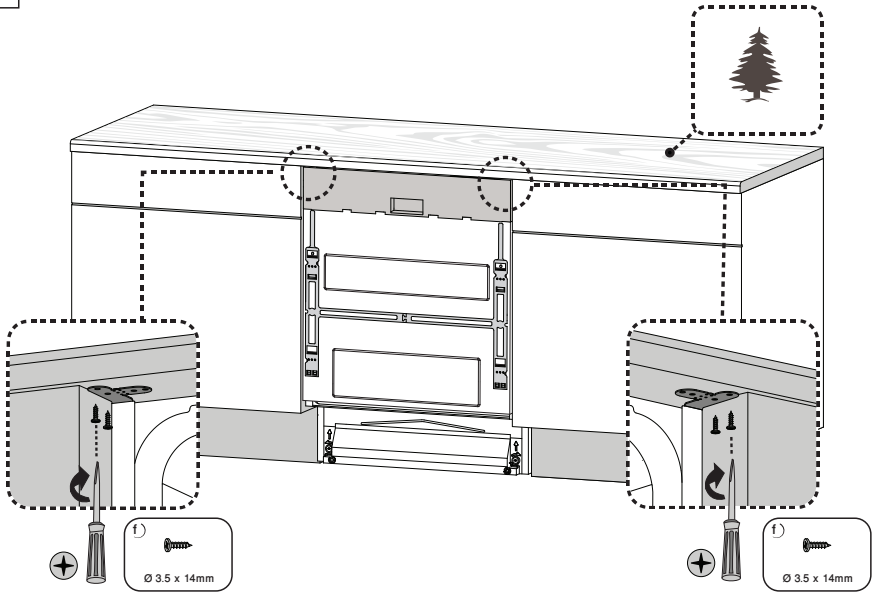

9

8

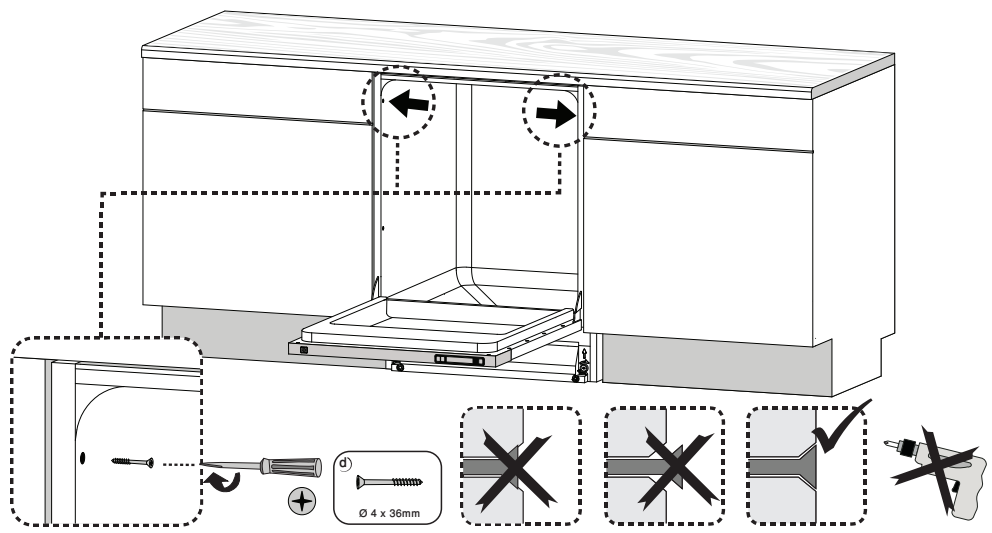

# 9

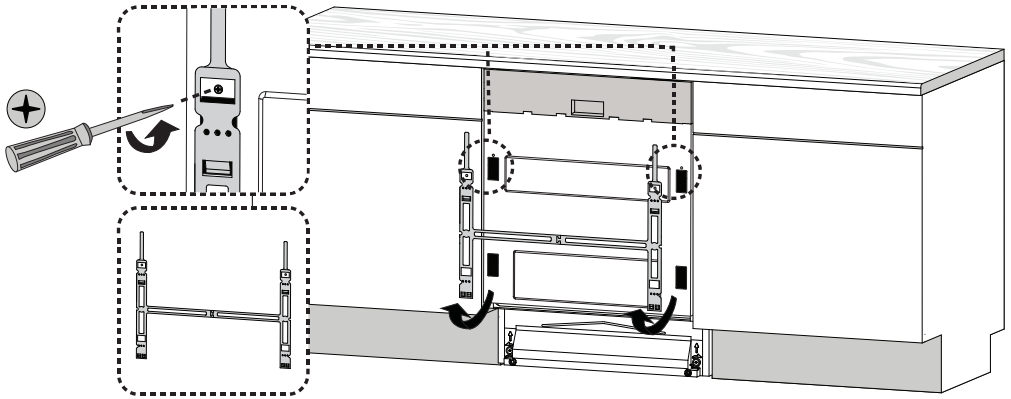

# 10

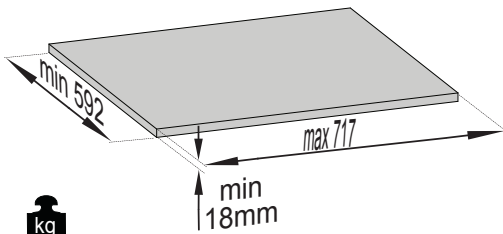

kg  
Max 6kg

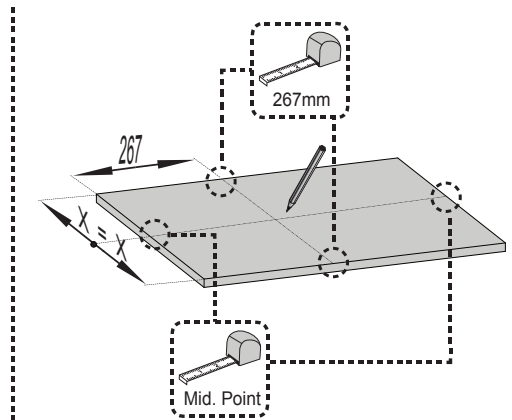

11

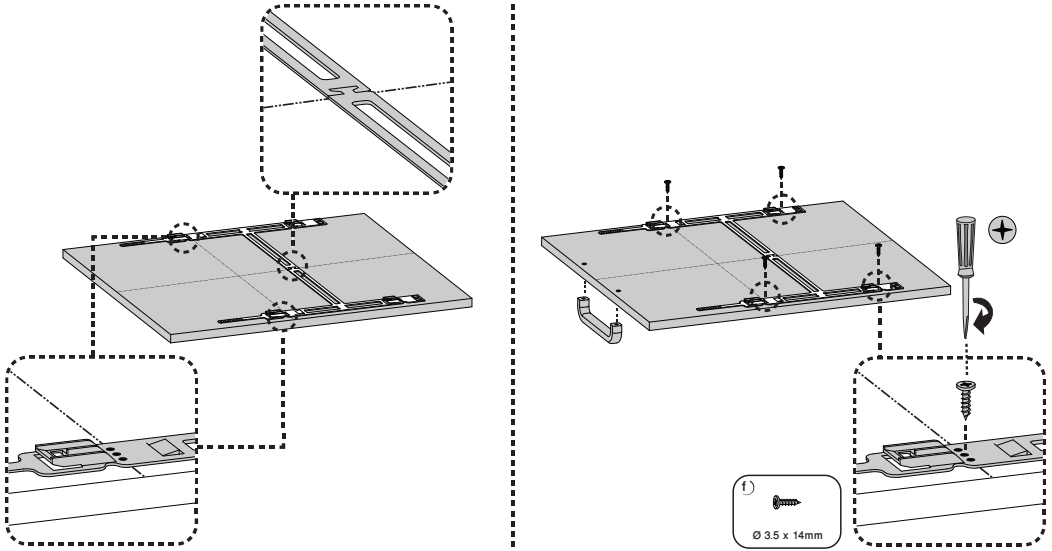

12

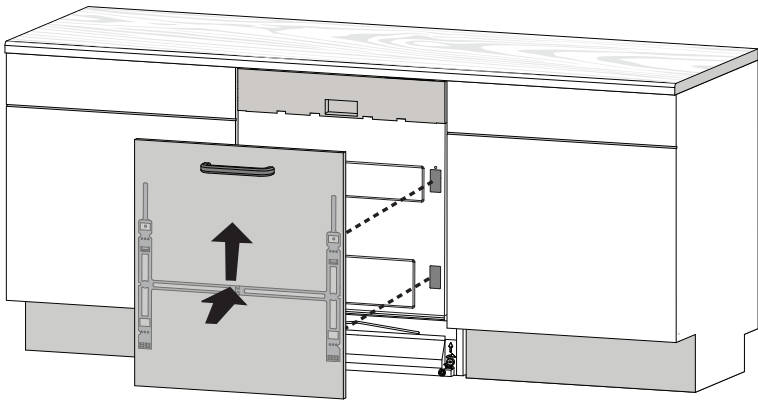



13

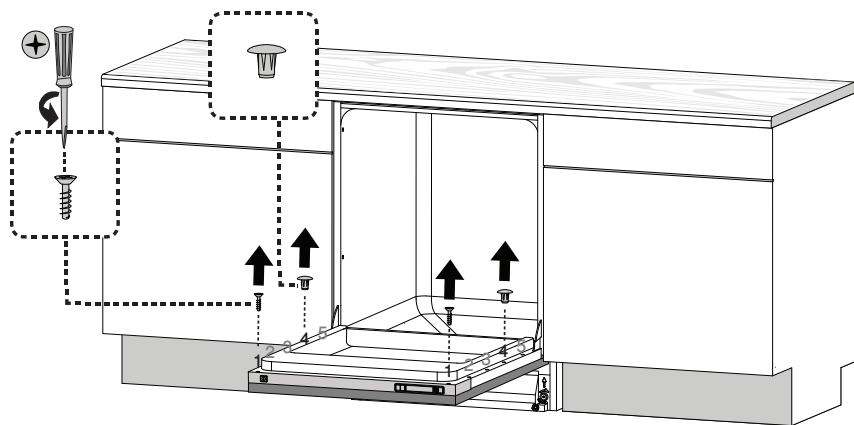

14

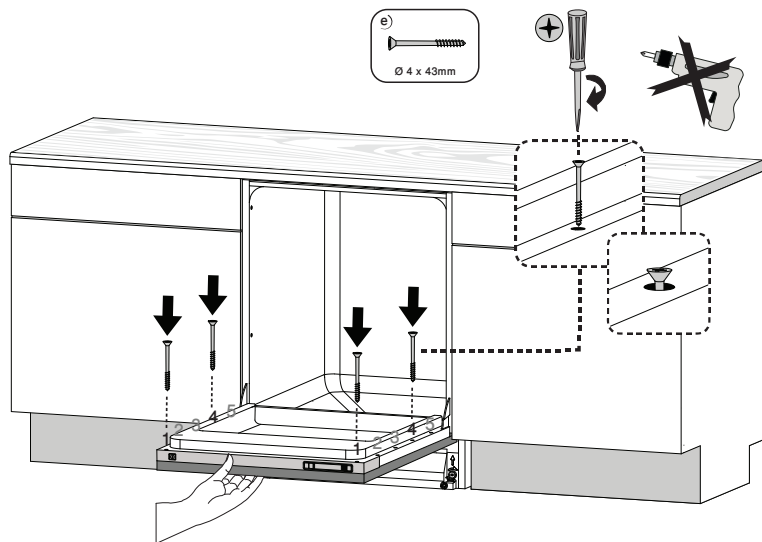

15

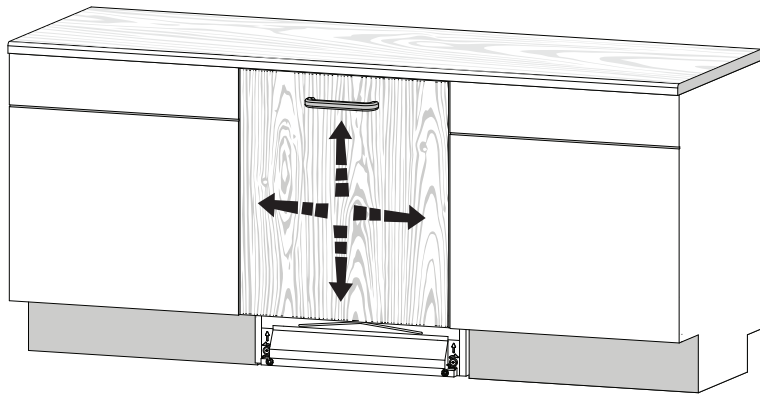

16

