

24 INCH TOP CONTROL ADA COMPATIBLE DISHWASHER

DDN25400X / DIN25400



Main Features

- 14 place settings
- 5 programs
- 48 dBA silent operation
- ENERGY STAR®
- ProSmart Inverter Motor
- Fast function
- Auto tablet function
- Flow through heater
- 5 level wash
- 3way euro filtering system
- NSF certified function
- Built-in high loop with air gap
- Stainless steel tank
- Fingerprint-free stainless steel

Flexible Baskets

- Height adjustable upper rack
- Sliding cutlery basket

Dimensions

- H x W x D: 32 1/4" x 23 9/16" x 22 1/2"
- ADA compatible
- Fits in European kitchen under counter spaces

CONTROLS	DDN25400X / DIN25400
Control Type	Electronic
Position	Top
MAIN FEATURES	
Loading Capacity (place settings)	14
Tub material	Stainless Steel
Inner door material	Stainless Steel
Interior illumination	No
Water Softener	No
DMSF overflow protection	Yes
5 level wash with 3rd spray arm	Yes
Delay timer up to 1-24 hour	Yes
3-way euro filter	Yes
Drying	Condensation
ProSmart Inverter motor	Yes
Turbidity sensor	Yes
Silence level, dBA	48 dBA
InnerClean	Yes
Autotablet function	Yes
1/2 load function	Yes
Sanitize function	Yes
Super rinse function	Yes
SteamGloss function	No
Fast function	Yes
AquaIntense function	No
IonGuard	No
Interior high loop with airgap	Yes
Power plug	Yes
PROGRAMS	
Number of programs	5
Scrub with AquaIntense	No
Heavy Plus (167F rinse temp.)	Yes
Heavy (158F rinse temp.)	No
Auto program (131F-149F rinse temp.)	No
AquaFlex	No
Normal (142F-145F rinse temp.)	Yes
Clean & Shine	Yes
Delicate (149F rinse temp.)	No
Glass Care	No
Express (131F rinse temp.)	Yes
Rinse & Hold	Yes
DISPLAY	
Program sequence	Yes/Digital Display
Rinse aid indicator	Electronic
Rinse aid indicator display	Yes
Salt indicator display	No
Light indicator on Floor	No
RACK SYSTEM	
Easy fold lower rack folding tines	No
Lower rack embossed stainless handle	No
Cutlery basket	Sliding
Upper rack (inset shelves)	2
Easy fold upper rack folding tines	No
Acrobat system adjustable upper rack	Unloaded
Multipurpose removable 3rd rack	No
Lower basket wine glass holder	No
Nylon coated racks	Yes
DIMENSIONS	
HxWxD, in.	32 1/4" x 23 9/16" x 22 1/2"
Product weight, lbs.	85
HxWxD, cm	81.8 x 59.8 x 57
Product weight, kg	39
ENVIRONMENTAL STANDARDS	
ENERGY STAR® qualified	Yes
Energy consumption, kWh/year	255
Water consumption, gal/cycle	3.5 - 5.0
RoHS compliant (Lead free)	Yes
OPTIONS	
Stainless Steel	DDN25400X
Panel Ready	DIN25400

24 INCH TOP CONTROL ADA COMPATIBLE DISHWASHER

DDN25400X / DIN25400

Outstanding Features



SilentTech

Quiet talks over after-dinner coffee, book reports written at the kitchen table, movie night in the adjoining room, all made possible by Beko's SilentTech insulation technology. SilentTech suppresses dishwasher noise while extra insulation keeps heat in, for a high energy efficiency combination that really cleans up.



ProSmart Inverter Motor

There's no reason to sacrifice the serenity of your kitchen for a dishwasher cycle. Our advanced ProSmart Inverter Motor that helps power Beko's cleaning is twice as quiet as standard motors. Plus, it saves water and energy, so you can have some peace with your quiet.



Height Adjustable Upper Rack

Raise the height of the upper basket to wash large plates below or lower it to accommodate tall glasses.

Sliding Cutlery Basket

For added flexibility, the sliding cutlery basket can be placed in any position along the front row of the lower rack.

Dimensions and Installation

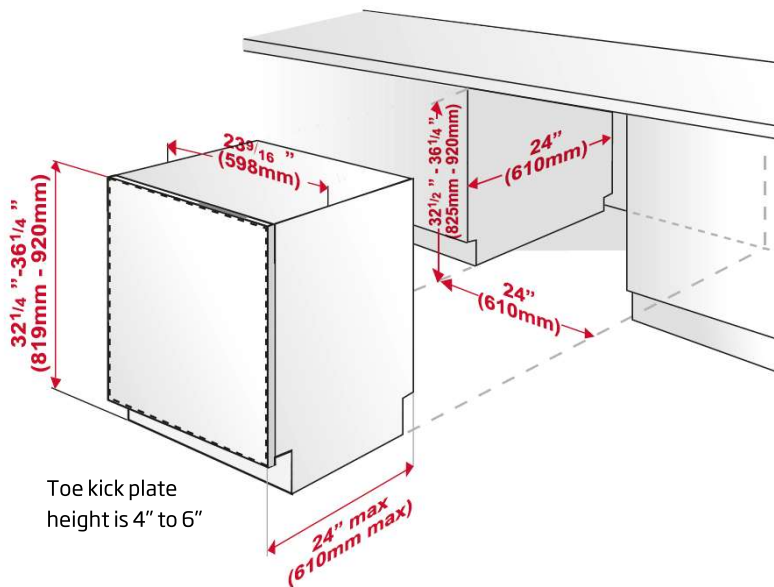

Panel requirements for panel ready models

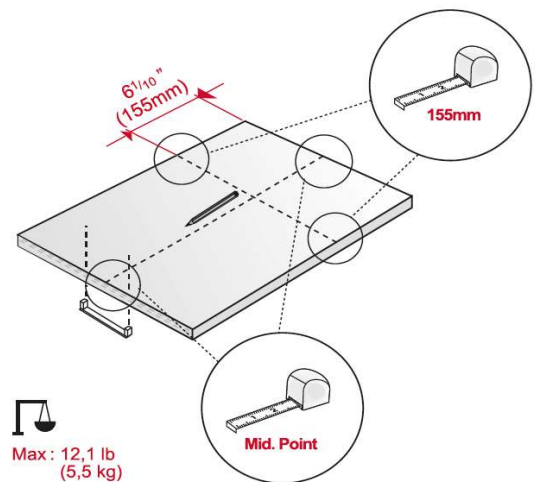

NOTE TO THE INSTALLER: All height, width and depth dimensions are shown in inches (as well as metric). Beko US Inc. reserves the absolute and unrestricted right to change product materials and specifications, at any time, without notice. Please visit our website www.blombergappliances.us or call 888 352 2356 to verify the latest specifications with final dimensional data and other details prior to installation and making a cutout. Applicable product limited warranty information may be found in accompanying product materials or you may contact your account manager for further details. Proper installation is the responsibility of the installer. Product failure due to improper installation is not covered under the Limited Warranty.